



SD Specifications
Part A2
SD Host Controller
Simplified Specification

Version 3.00

February 25, 2011

Technical Committee
SD Association

Revision History

Date	Version	Changes compared to previous issue
April 3, 2006	1.00	The first release of the Host Controller Simplified Specification
February 8, 2007	2.00	Support Advanced DMA2, Test Registers and 64-bit system bus. Apply changes in the Supplementary Notes Ver1.00 Draft. Some typos are fixed.
February 25, 2011	3.00	Supported UHS-I Interlace 64-bit Descriptor is removed because it will be modified in Ver4.00. Page 16: 64-bit Descriptor Page 40: DMA Select Fixed Some typos in SDIO Ver3.00

Release of SD Simplified Specification

The following conditions apply to the release of the SD simplified specification ("Simplified Specification") by the SD Card Association. The Simplified Specification is a subset of the complete SD Specification which is owned by the SD Card Association.

Publisher and Copyright Holder:

SD Card Association
2400 Camino Ramon, Suite 375
San Ramon, CA 94583 USA
Telephone: +1 (925) 275-6615,
Fax: +1 (925) 886-4870
E-mail: office@sdc card.org

Notes:

This Simplified Specification is provided on a non-confidential basis subject to the disclaimers below. Any implementation of the Simplified Specification may require a license from the SD Card Association or other third parties.

Disclaimers:

The information contained in the Simplified Specification is presented only as a standard specification for SD Cards and SD Host/Ancillary products and is provided "AS-IS" without any representations or warranties of any kind. No responsibility is assumed by the SD Card Association for any damages, any infringements of patents or other right of the SD Card Association or any third parties, which may result from its use. No license is granted by implication, estoppel or otherwise under any patent or other rights of the SD Card Association or any third party. Nothing herein shall be construed as an obligation by the SD Card Association to disclose or distribute any technical information, know-how or other confidential information to any third party.

Conventions Used in This Document

Naming Conventions

- Register names are shown in italic text such as *Present State*.
- Names of bits or fields within registers are in bold text such as **Buffer Write Enable**.
- Signal names are capitalized, bold and italic, followed by '#' if low active such as ***SDCD#***.
- Some terms are capitalized to distinguish their definition from their common English meaning. Words not capitalized have their common English meaning.
- Register names and the names of fields and bits in registers and headers are presented with the first letter capitalized and the remainder in lower case.

Numbers and Number Bases

- Hexadecimal numbers are written with a lower case "h" suffix, e.g., FFFFh and 80h.
- Binary numbers are written with a lower case "b" suffix (e.g., 10b).
- Binary numbers larger than four digits are written with a space dividing each group of four digits, as in 1000 0101 0010b.
- All other numbers are decimal.

Key Words

- May: Indicates flexibility of choice with no implied recommendation or requirement.
- Shall: Indicates a mandatory requirement. Designers shall implement such mandatory requirements to ensure interchangeability and to claim conformance with the specification.
- Should: Indicates a strong recommendation but not a mandatory requirement. Designers should give strong consideration to such recommendations, but there is still a choice in implementation.

Special Terms

In this document, the following terms shall have special meaning:

- Host Controller Refers to an SD Host Controller that complies with this Specification.
- Host Driver Refers to the OS-specific driver for a Host Controller
- Card Driver Refers to a driver for an SD/SDIO card or card function
- Host System (or System) Refers to the entire system, such as a cellular phone, containing the Host Controller

Implementation Notes

- Some sections of this document provide guidance to Host Controller or Host Driver implementers. To distinguish non-mandatory guidance from other parts of the SD Host Specification, it will be shown as follows:

Implementation Note: This is an example of an implementation note.
--

Table of Contents

1. Overview of the SD Standard Host	1
1.1 Scope of the Standard SD Host	1
1.2 Register Map	2
1.3 Multiple Slot Support.....	3
1.4 Supporting DMA.....	3
1.5 SD Command Generation	4
1.6 Suspend and Resume Mechanism	4
1.7 Buffer Control	5
1.7.1 Control of Buffer Pointer.....	5
1.7.2 Determining Buffer Block Length.....	7
1.7.3 Dividing Large Data Transfer.....	7
1.8 Relationship between Interrupt Control Registers	8
1.9 HW Block Diagram and Timing Part.....	10
1.10 Power State Definition of SD Host Controller.....	11
1.11 Auto CMD12.....	12
1.12 Controlling SDCLK	13
1.13 Advanced DMA.....	14
1.13.1 Block Diagram of ADMA2.....	14
1.13.2 An Example of ADMA2 Programming.....	15
1.13.3 Data Address and Data Length Requirements	15
1.13.4 Descriptor Table	16
1.13.5 ADMA2 States	17
1.14 Test Registers	18
1.15 Block Count.....	18
1.16 Sampling Clock Tuning	18
2. SD Host Standard Register.....	19
2.1 Summary of register set.....	19
2.1.1 SD Host Control Register Map	19
2.1.2 Configuration Register Types	20
2.1.3 Register Initial Values	20
2.1.4 Reserved Bits of Register.....	20
2.2 SD Host Standard Register	21
2.2.1 SDMA System Address / Argument 2 Register (Offset 000h).....	21
2.2.2 Block Size Register (Offset 004h)	22
2.2.3 Block Count Register (Offset 006h).....	24
2.2.4 Argument 1 Register (Offset 008h).....	25
2.2.5 Transfer Mode Register (Offset 00Ch)	26
2.2.6 Command Register (Offset 00Eh)	29
2.2.7 Response Register (Offset 010h)	31

SD Host Controller Simplified Specification Version 3.00

2.2.8 Buffer Data Port Register (Offset 020h).....	32
2.2.9 Present State Register (Offset 024h).....	33
2.2.10 Host Control 1 Register (Offset 028h)	40
2.2.11 Power Control Register (Offset 029h).....	42
2.2.12 Block Gap Control Register (Offset 02Ah).....	43
2.2.13 Wakeup Control Register (Offset 02Bh)	45
2.2.14 Clock Control Register (Offset 02Ch)	46
2.2.15 Timeout Control Register (Offset 02Eh)	49
2.2.16 Software Reset Register (Offset 02Fh).....	50
2.2.17 Normal Interrupt Status Register (Offset 030h)	52
2.2.18 Error Interrupt Status Register (Offset 032h)	57
2.2.19 Normal Interrupt Status Enable Register (Offset 034h)	60
2.2.20 Error Interrupt Status Enable Register (Offset 036h)	62
2.2.21 Normal Interrupt Signal Enable Register (Offset 038h)	64
2.2.22 Error Interrupt Signal Enable Register (Offset 03Ah)	66
2.2.23 Auto CMD Error Status Register (Offset 03Ch)	68
2.2.24 Host Control 2 Register (Offset 03Eh).....	70
2.2.25 Capabilities Register (Offset 040h).....	74
2.2.26 Maximum Current Capabilities Register (Offset 048h)	80
2.2.27 Force Event Register for Auto CMD Error Status (Offset 050h).....	81
2.2.28 Force Event Register for Error Interrupt Status (Offset 052h).....	82
2.2.29 ADMA Error Status Register (Offset 054h)	83
2.2.30 ADMA System Address Register (Offset 058h)	85
2.2.31 Preset Value Registers (Offset 06F-060h).....	86
2.2.32 Shared Bus Control Register (Offset 0E0h).....	88
2.2.33 Slot Interrupt Status Register (Offset 0FCh).....	91
2.2.34 Host Controller Version Register (Offset 0FEh).....	91
3. SEQUENCE	92
3.1 SD Card Detection	92
3.2 SD Clock Control	94
3.2.1 SD Clock Supply Sequence	94
3.2.2 SD Clock Stop Sequence	95
3.2.3 SD Clock Frequency Change Sequence.....	95
3.3 SD Bus Power Control.....	96
3.4 Changing Bus Width.....	98
3.5 Timeout Setting on DAT Line	99
3.6 Card Initialization and Identification	100
3.6.1 Signal Voltage Switch Procedure	104
3.7 SD Transaction Generation.....	106
3.7.1 Transaction Control without Data Transfer Using DAT Line.....	107
3.7.1.1 The Sequence to Issue a SD Command.....	107
3.7.1.2 The Sequence to Finalize a Command.....	109
3.7.2 Transaction Control with Data Transfer Using DAT Line.....	110
3.7.2.1 Not using DMA.....	111
3.7.2.2 Using SDMA	113
3.7.2.3 Using ADMA	115
3.8 Abort Transaction	117
3.8.1 Asynchronous Abort	117

SD Host Controller Simplified Specification Version 3.00

3.8.2 Synchronous Abort	118
3.9 Changing Bus Speed Mode.....	119
3.10 Error Recovery	121
3.10.1 Error Interrupt Recovery	123
3.10.2 Auto CMD12 Error Recovery	126
3.11 Wakeup Control (Optional).....	128
3.12 Suspend/Resume (Optional).....	130
3.12.1 Suspend Sequence	130
3.12.2 Resume Sequence.....	132
3.12.3 Read Transaction Wait / Continue Timing	133
3.12.4 Write Transaction Wait / Continue Timing.....	135
Appendix A (Normative) : Reference	137
A.1 Reference.....	137
Appendix B (Normative) : Special Terms	138
B.1 Abbreviations and Terms.....	138
Appendix C : PCI Configuration Register.....	139
C.1 Register Maps.....	139
C.2 SD Controller Configuration Register MAP	140
C.3 PCI Configuration Register	141
C.3.1 Class Code Register (Offset 09h)	141
C.3.2 Base Address Register (Offset 10h)	142
C.3.3 Slot Information Register (Offset 40h)	143
C.4 The Relation between Device State, Power and Clock.....	144
C.5 Generate PME Interrupt by the Wakeup Events.....	145
Appendix D : Shared Bus Supported Host Controller.....	146

Table of Figures

Figure 1-1 : Host Hardware and Driver Architecture	1
Figure 1-2 : Classification of the Standard Register Map.....	2
Figure 1-3 : Register Map for Multiple Slots Controller	3
Figure 1-4 : Suspend and Resume Mechanism	4
Figure 1-5 : Buffer Size Relation between Host and Card	7
Figure 1-6 : Logical Relation for Interrupt Registers	8
Figure 1-7 : Block Diagram of Host Controller	10
Figure 1-8 : Block Diagram of ADMA2.....	14
Figure 1-9 : An Example of ADMA2 Data Transfer	15
Figure 1-10 : 32-bit Address Descriptor Table	16
Figure 1-11 : State Diagram of the ADMA2.....	17
Figure 2-1 : SDMA System Address / Argument 2 Register.....	21
Figure 2-2 : Block Size Register	22
Figure 2-3 : Block Count Register	24
Figure 2-4 : Argument 1 Register	25
Figure 2-5 : Transfer Mode Register.....	26
Figure 2-6 : Command Register	29
Figure 2-7 : Response Register.....	31
Figure 2-8 : Buffer Data Port Register	32
Figure 2-9 : Present State Register	33
Figure 2-10 : Card Detect State.....	34
Figure 2-11 : Timing of Command Inhibit (DAT) and Command Inhibit (CMD) with Data Transfer	39
Figure 2-12 : Timing of Command Inhibit (DAT) for the Case of Response with Busy	39
Figure 2-13 : Timing of Command Inhibit (CMD) for the Case of No Response Command.....	39
Figure 2-14 : Host Control 1 Register.....	40
Figure 2-15 : Power Control Register	42
Figure 2-16 : Block Gap Control Register.....	43
Figure 2-17 : Wakeup Control Register	45
Figure 2-18 : Clock Control Register	46
Figure 2-19 : Timeout Control Register.....	49
Figure 2-20 : Software Reset Register	50
Figure 2-21 : Normal Interrupt Status Register	52
Figure 2-22 : Error Interrupt Status Register.....	57
Figure 2-23 : Normal Interrupt Status Enable Register	60
Figure 2-24 : Error Interrupt Status Enable Register	62
Figure 2-25 : Normal Interrupt Signal Enable Register.....	64
Figure 2-26 : Error Interrupt Signal Enable Register	66
Figure 2-27 : Auto CMD Error Status Register.....	68
Figure 2-28 : Host Control 2 Register.....	70
Figure 2-29 : Sampling Clock Tuning Procedure	73
Figure 2-30 : Capabilities Register	74
Figure 2-31 : Maximum Current Capabilities Register	80
Figure 2-32 : Force Event Register for Auto CMD Error Status	81
Figure 2-33 : Force Event Register for Error Interrupt Status	82
Figure 2-34 : ADMA Error Status Register.....	83
Figure 2-35 : ADMA System Address Register	85
Figure 2-36 : Fields of A Preset Value Register	86
Figure 2-37 : Shared Bus Control Register.....	88
Figure 2-38 : An Example Timing of Selecting Clock Pin.....	90
Figure 2-39 : Slot Interrupt Status Register	91

SD Host Controller Simplified Specification Version 3.00

Figure 2-40 : Host Controller Version Register	91
Figure 3-1 : Double Box Notation	92
Figure 3-2: SD Card Detect Sequence	92
Figure 3-3: SD Clock Supply Sequence	94
Figure 3-4: SD Clock Stop Sequence	95
Figure 3-5: SD Clock Change Sequence.....	95
Figure 3-6: SD Bus Power Control Sequence	96
Figure 3-7: Change Bus Width Sequence	98
Figure 3-8: Timeout Setting Sequence	99
Figure 3-9 : Card Initialization and Identification.....	101
Figure 3-10 : Signal Voltage Switch Procedure	104
Figure 3-11: SD Command Issue Sequence	107
Figure 3-12: Command Complete Sequence	109
Figure 3-13: Transaction Control with Data Transfer Using DAT Line Sequence (Not using DMA)	111
Figure 3-14: Transaction Control with Data Transfer Using DAT Line Sequence (Using SDMA).....	113
Figure 3-15: Transaction Control with Data Transfer Using DAT Line Sequence (Using ADMA).....	115
Figure 3-16: Asynchronous Abort Sequence	117
Figure 3-17: Synchronous Abort Sequence.....	118
Figure 3-18 : High Speed Mode Setting for Combo Card	119
Figure 3-19 : Error Report and Recovery	121
Figure 3-20: Return Status of Auto CMD12 Error Recovery	122
Figure 3-21: Error Interrupt Recovery Sequence.....	124
Figure 3-22 : Auto CMD12 Error Recovery Sequence.....	126
Figure 3-23: Wakeup Control before Standby Mode.....	128
Figure 3-24: Wakeup from Standby	129
Figure 3-25 : The Sequence for Suspend.....	130
Figure 3-26 : The Sequence for Resume	132
Figure 3-27 : Wait Read Transfer by Stop At Block Gap Request	133
Figure 3-28 : Stop At Block Gap Request is Not Accepted at the Last Block of the Read Transfer	134
Figure 3-29 : Continue Read Transfer by Continue Request.....	134
Figure 3-30 : Wait Write Transfer by Stop At Block Gap Request.....	135
Figure 3-31 : Stop At Block Gap Request is Not Accepted at the Last Block of the Write Transfer	136
Figure 3-32 : Continue Write Transfer by Continue Request.....	136
Figure C- 1 : Register Set for PCI Device (Example for 2 slots)	139
Figure C- 2 : Vendor Specific Register Area Extension	139
Figure C- 3 : PCI Config. Class Code Register	141
Figure C- 4 : PCI Config. Base Address Register for 256Byte Register Map	142
Figure C- 5 : PCI Config. Base Address Register for 512Byte Register Map	142
Figure C- 6 : PCI Config. Slot Information Register.....	143
Figure C- 7 : Condition to Generate PME Interrupt	145
Figure D- 1 : Example Configuration Supporting Card Slot and Shared Bus.....	146

Table of Tables

Table 1-1 : Supported Registers	2
Table 1-2 : Registers to Generate SD Command	4
Table 1-3 : Relations between Address and Byte Enable	5
Table 1-4 : Available Byte Enable Pattern for Buffer Data Port Register.....	6
Table 1-5 : Interrupt Signal Table	9
Table 1-6 : Wakeup Signal Table	9
Table 1-7 : Summary of Register Status for Data Transfer	10
Table 1-8 : Power State Definition	11
Table 1-9 : Relation between Auto CMD12 and CMD_wo_DAT	12
Table 1-10 : Controlling SDCLK by the SD Bus Power and SD Clock Enable.....	13
Table 1-11 : ADMA2 Length Field	16
Table 1-12 : 64-bit Address Descriptor Table (Removed)	16
Table 1-13 : ADMA2 States.....	17
Table 1-14 : Host Controller Data Transfer Length	18
Table 2-1 : SD Host Controller Register Map.....	19
Table 2-2 : Register (and Register Bit-Field) Types	20
Table 2-3 : SDMA System Address / Argument 2 Register	21
Table 2-4 : Block Size Register.....	23
Table 2-5 : Block Count Register	24
Table 2-6 : Argument 1 Register	25
Table 2-7 : Transfer Mode Register	28
Table 2-8 : Determination of Transfer Type.....	28
Table 2-9 : Command Register.....	30
Table 2-10 : Relation between Parameters and the Name of Response Type	30
Table 2-11 : Response Register	31
Table 2-12 : Response Bit Definition for Each Response Type.	31
Table 2-13 : Buffer Data Port Register.....	32
Table 2-14 : Present State Register (Part 1)	34
Table 2-15 : Present State Register (Part 2)	38
Table 2-16 : Host Control 1 Register	41
Table 2-17 : Power Control Register.....	42
Table 2-18 : Block Gap Control Register	44
Table 2-19 : Wakeup Control Register.....	45
Table 2-20 : Clock Control Register.....	48
Table 2-21 : Timeout Control Register	49
Table 2-22 : Software Reset Register.....	51
Table 2-23 : Normal Interrupt Status Register.....	56
Table 2-24 : Error Interrupt Status Register	59
Table 2-25 : The Relation between Command CRC Error and Command Timeout Error.....	59
Table 2-26 : Normal Interrupt Status Enable Register	61
Table 2-27 : Error Interrupt Status Enable Register	63
Table 2-28 : Normal Interrupt Signal Enable Register	65
Table 2-29 : Error Interrupt Signal Enable Register	67
Table 2-30 : Auto CMD Error Status Register	69
Table 2-31 : The Relation between CRC Error and Timeout Error for Auto CMD	69
Table 2-32 : Host Control 2 Register	72
Table 2-33 : Capabilities Register (Part 1)	77
Table 2-34 : Capabilities Register (Part 2)	79
Table 2-35 : Maximum Current Capabilities Register.....	80
Table 2-36 : Maximum Current Value Definition	80

SD Host Controller Simplified Specification Version 3.00

Table 2-37 : Force Event Register for Auto CMD Error Status.....	81
Table 2-38 : Force Event for Error Interrupt Status Register.....	83
Table 2-39 : ADMA Error Status Register.....	84
Table 2-40 : ADMA System Address Register.....	85
Table 2-41 : Preset Value Registers	86
Table 2-42 : Preset Value Register Select Condition	86
Table 2-43 : Fields of A Preset Value Register.....	87
Table 2-44 : Shared Bus Control Register	90
Table 2-45 : Slot Interrupt Status Register.....	91
Table 2-46 : Host Controller Version	91
Table 3-1 Suspend / Resume Condition	131
Table C- 1 : PCI Configuration Register for Standard SD Host Controller	140
Table C- 2 : PCI Config. Class Code Register	141
Table C- 3 : PCI Config. Base Address Register for 256Byte Register Map	142
Table C- 4 : PCI Config. Base Address Register for 512Byte Register Map	142
Table C- 5 : PCI Config. Slot Information Register	143
Table C- 6 : The Relation between Device State, Power and Clock	144

1. Overview of the SD Standard Host

The Secure Digital (SD) Host Standard Specification is the SD Association's (SDA) guideline for designing SD Host Controllers and related vendor products. Within the scope of the SD Association's adherence to this specification is not mandatory. It is the Host Controller vendor's responsibility to design products that comply with the SD Specification and where possible to use standard Host Drivers. OS vendor, IHVs and OEMs may require compliance according to their own policies so adherence is recommended.

1.1 Scope of the Standard SD Host

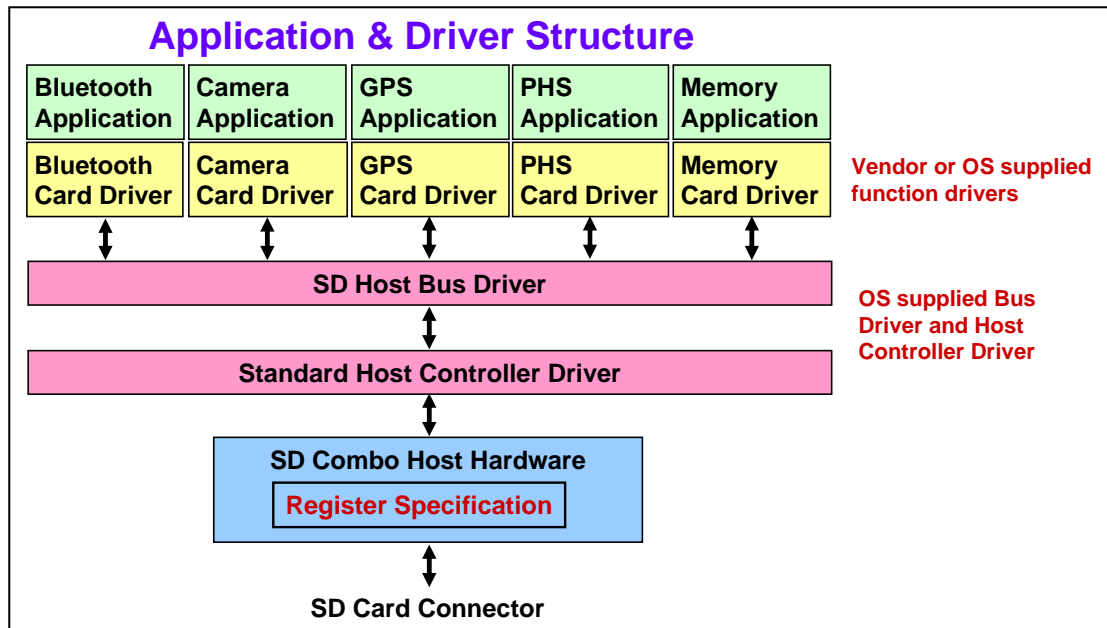

Figure 1-1 : Host Hardware and Driver Architecture

Defining a standard SD Host Controller is intended to promote increase of SD host products which can use SD memory cards and SDIO cards. Host Controller standardization enables Operating System (OS) Vendors to develop Host Driver (SD Host Bus Driver and Standard Host Controller Driver) that works with Host Controllers from any vendor.

Applications may in addition require the Card Drivers that supplied by card vendors or OS vendor. The Card Drivers communicate with the SD Host Bus Driver using a driver interface specified by the OS.

Implementation Note:

This specification can be applied to any system bus interface. The interface between the Host Driver and its parent system driver (if any) is not defined by this specification.

1.2 Register Map

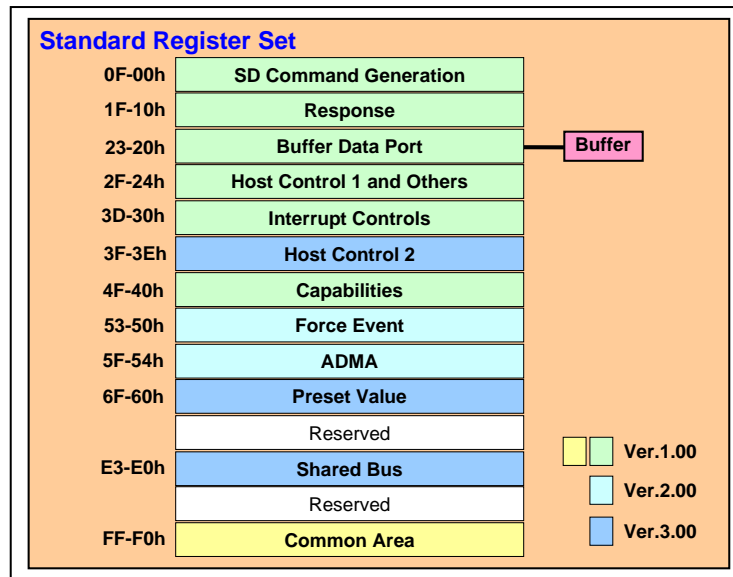

Figure 1-2 : Classification of the Standard Register Map

The standard register map is classified in 12 parts listed below. The Host Controller shall support byte, word and double word accesses to these registers. Reserved bits in all registers shall be fixed to zero. The Host Controller shall ignore writes to reserved bits; however, the Host Driver should write them as zero to ensure compatibility with possible future revisions to this Specification.

No.	Register Name	Version 1.00	Version 2.00	Version 3.00	Comment
1	SD command generation	Mand.	←	←	Parameters to generate SD commands
2	Response	Mand.	←	←	Response value from the card
3	Buffer Data port	Mand.	←	←	Data access port to the internal buffer
4	Host control 1 and Others	Mand.	←	←	Present State, controls for the SD Bus, Host reset and so on
5	Interrupt controls	Mand.	←	←	Interrupt statuses and enables
6	Capabilities	Mand.	←	←	Vendor specific host controller support information
7	Host Control 2	N/A	N/A	Mand.	Extension of Host Control Register
8	Force Event	N/A	Mand.	Mand.	Test register to generate events by software
9	ADMA	N/A	Opt.	Mand.	Advanced DMA registers
10	Preset Value	N/A	N/A	Mand.	Preset for clock frequency select and driver strength select
11	Shared Bus	N/A	N/A	Opt.	Device controls for shared bus system
12	Common area	Mand.	←	←	Common information area

Mand. : Mandatory, Opt. : Optional, N/A : Not Available

Table 1-1 : Supported Registers

1.3 Multiple Slot Support

One Standard Register Set is defined for each slot. If the Host Controller has two slots, two register sets is required. Each slot is controlled independently. This enables support for combinations of bus interface voltage, bus timing and SD Clock frequencies.

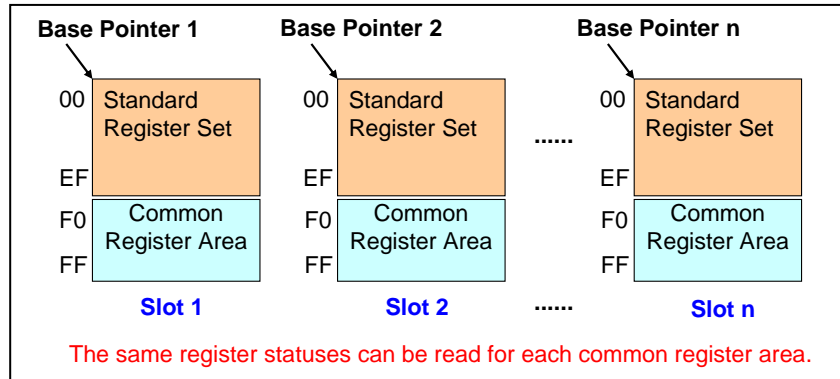

Figure 1-3 : Register Map for Multiple Slots Controller

Figure 1-3 shows the register map for a multiple slot Host Controller. The Host Driver shall determine the number of slots and base pointers to each slot's Standard Register Set using PCI Configuration register or vendor specific methods. Offsets from 0F0h to 0FFh are reserved for the Common register area that defines information for slot control and common status. The common register area is accessible from any slot's register set. This allows software to control each slot independently, since it has access to the *Slot Interrupt Status* register and the *Host Controller Version* register from each register set.

1.4 Supporting DMA

The Host Controller provides a "programmed I/O" method for the Host Driver to transfer data using the *Buffer Data Port* register. Optionally, Host Controller implementers may support data transfer using DMA. The DMA algorithm defined in the SD Host Controller Standard Specification Version 1.00 is called SDMA (Single Operation DMA). Only one SD command transaction can be executed per a SDMA operation. Support of SDMA can be checked by the **SDMA Support** in the *Capabilities* register.

This specification defines a DMA transfer algorithm called ADMA (Advanced DMA). ADMA provides data transfer between system memory and SD card without interruption of CPU execution. Support of ADMA can be checked by the *Capabilities* register. Refer to Section 1.13 for more details about ADMA. When the term "DMA" is used in this document, it applies to both SDMA and ADMA.

Prior to using DMA, the Host Driver shall confirm that both the Host Controller and the system bus support it (PCI bus can support DMA). DMA shall support both single block and multiple-block transfers. Host Controller registers shall remain accessible for issuing non-DAT line commands during a DMA transfer execution. The result of a DMA transfer shall be the same regardless of the system bus data transfer method.

The Host Driver can stop and restart a DMA operation by the control bits in the *Block Gap Control* register. By setting **Stop At Block Gap Request**, a DMA operation can be stopped at block gap. By setting **Continue Request**, DMA operation can be restarted. Refer to the *Block Gap Control* register for more details. If an error occurs, DMA operation shall be stopped. To abort DMA transfer, Host driver shall reset the Host Controller by the **Software Reset For DAT Line** in the *Software Reset* register and issue CMD12 if multiple-block read / write command is executing.

1.5 SD Command Generation

	SDMA Command	ADMA Command	CPU data Transfer	Non-DAT Transfer
SDMA System Address / Argument 2	Yes / No	No / Auto CMD23	No / Auto CMD23	No / No
Block Size	Yes	Yes	Yes	No (Protected)
Block Count	Yes	Yes	Yes	No (Protected)
Argument 1	Yes	Yes	Yes	Yes
Transfer Mode	Yes	Yes	Yes	No (Protected)
Command	Yes	Yes	Yes	Yes

Table 1-2 : Registers to Generate SD Command

Table 1-2 shows register settings (at offsets from 000h to 00Fh in the register set) necessary for three types of transactions: SDMA generated transfers, ADMA generated transfers, CPU data transfers (using "programmed I/O") and non-DAT transfers. When initiating a transaction, the Host Driver should program these registers sequentially from 000h to 00Fh. The beginning register offset may be calculated based on the type of transaction. The last written offset shall be always 00Fh because writing to the upper byte of the *Command* register shall trigger issuance of an SD command.

The Host Driver should not read the *SDMA System Address*, *Block Size* and *Block Count* registers during a data transaction unless the transfer is stopped or suspended because the value is changing and not stable. To prevent destruction of registers using data transfer when issuing command, the *Block Size*, *Block Count* and *Transfer Mode* registers shall be write protected by the Host Controller while **Command Inhibit (DAT)** is set to 1 in the *Present State* register. (The *SDMA System Address* cannot be protected by this signal.) The Host Driver shall not write the *Argument 1* and *Command* registers while **Command Inhibit (CMD)** is set to 1.

1.6 Suspend and Resume Mechanism

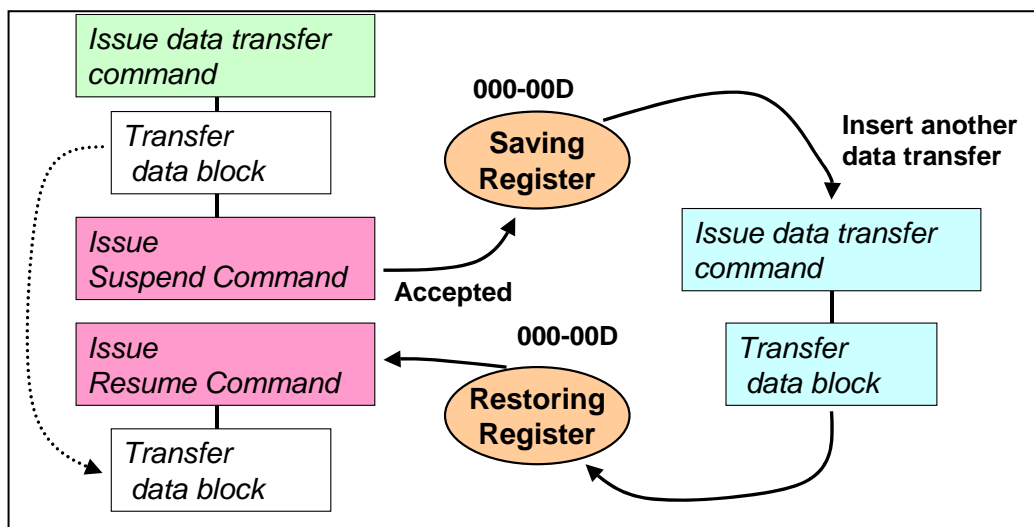

Figure 1-4 : Suspend and Resume Mechanism

SD Host Controller Simplified Specification Version 3.00

Support for Suspend/Resume can be determined by checking **Suspend/Resume Support** in the *Capabilities* register. When the SD card accepts a suspend request, the Host Driver saves information in the first 14bytes registers (that is, offsets 000h-00dh) before issuing other SD commands. On resuming, the Host Driver restores these registers and then issues the Resume command to continue suspended operation.

The SDIO card sets the **DF** (Resume Data Flag) in the response to the Resume command. (Since the Suspend and Resume commands are CMD52 operations, the response data is actually the Function Select Register in the CCCR.) If **DF** is set to 0, it means the SDIO card cannot continue data transfer while suspended. This bit can be used to control data transfers and interrupt cycles. If the Resume Data Flag is set to 0, no more data is transferred and an interrupt cycle is started if the transaction being resumed is in 4-bit mode. If **DF** is set to 1, data transfers continue. The Suspend/Resume protocol is described in the SDIO Specification (SD card Specification part E1).

Note: To use Suspend and Resume function, it is necessary that SDIO Card supports the Suspend and Resume commands and Read Wait control.

1.7 Buffer Control

The Host Controller has a data buffer for data transfer. The Host Driver accesses internal buffer through the 32-bit *Buffer Data Port* register. Followings show some rules to access the buffer.

1.7.1 Control of Buffer Pointer

Internally, the Host Controller maintains a pointer to control the data buffer. The pointer is not directly accessible by the Host Driver. Every time the *Buffer Data Port* register is accessed, the pointer is incremented depending on amount of data written to the buffer. In order to accommodate a variety of system busses, this pointer shall be implemented regardless of system bus width (8-bit, 16-bit, 32-bit or 64-bit system bus width can be supported). To specify control of the pointer, the Host Controller data buffer interface shall have the following characteristics:

(1) System Bus Width and Byte Enable Address

8-bit, 16-bit, 32-bit or 64-bit system bus is supported. To specify byte position for *Buffer Data Port* register (4 bytes), Byte Enable (**BE**[*i*]) or Lower Address (**A**[*i*]) is used. Table 1-3 shows the relation between lower address and byte enable depending on system bus width. The *Buffer Data Port* register can be accessed by **BE**[3:0] for 64-bit system bus which has **BE**[7:0].

System Bus	A[02]	A[01]	A[00]	BE[3] D[31:24]	BE[2] D[23:16]	BE[1] D[15:08]	BE[0] D[07:00]
64-bit	No	No	No	Yes	Yes	Yes	Yes
32-bit	Yes	No	No	Yes	Yes	Yes	Yes
16-bit	Yes	Yes	No	No	No	Yes	Yes
8-bit	Yes	Yes	Yes	No	No	No	Yes ^{*2}

*1 "Yes" means the signal is used for control and "No" means the signal is not used.

*2 : BE[00] for 8-bit bus is always 1 therefore it may not be defined.

Table 1-3 : Relations between Address and Byte Enable

(2) Sequential and continuous access

The *Buffer Data Port* register shall be accessed by sequential and continuous manner. The buffer pointer is controlled by the Byte Enable patterns when accessing to the Buffer Data Port register. So Byte Enable patterns shall be sequential and continuous as well. The order of Byte Enable is

SD Host Controller Simplified Specification Version 3.00

according to little endian format. For example, **BE[1]** is accessed, next access shall start from **BE[2]**. Random or skipped access is not allowed.

Table 1-4 shows possible byte enables patterns that shall be supported by the Host Controller. However, if the system controller supports write merge, it may generate the other byte enable patterns. To avoid generating unsupported byte enable patterns for the 32-bit or 64-bit bus system, the Host Driver is allowed to use word or double word access to the *Buffer Data Port* register except for the last access to every block data.

OK BE[3:0]=0011b (2-byte) => BE[3:0]=1100b (2-byte) => BE[3:0]=0011b (2-byte)
 OK BE[3:0]=1100b (2-byte) => BE[3:0]=1111b (4-byte) => BE[3:0]=0011b (2-byte)
 OK BE[3:0]=1111b (4-byte) => BE[3:0]=1111b (4-byte) => BE[3:0]=1111b (4-byte)
 Not OK BE[3:0]=0011b (2-byte) => BE[3:0]=0011b (2-byte) (Cannot skip BE[2],BE[3])
 Not OK BE[3:0]=0011b (2-byte) => BE[3:0]=1111b (4-byte) (Cannot skip BE[2],BE[3])

Byte Enable		BE[3]	BE[2]	BE[1]	BE[0]
Data Bus		D[31:24]	D[23:16]	D[15:08]	D[07:00]
Access Type	4-byte	1	1	1	1
	2-byte	0	0	1	1
	2-byte	1	1	0	0
	1-byte	0	0	0	1
	1-byte	0	0	1	0
	1-byte	0	1	0	0
	1-byte	1	0	0	0

* 1 means BE is valid and 0 means BE is not valid.

Table 1-4 : Available Byte Enable Pattern for Buffer Data Port Register

(3) Buffer Control with Block Size

The buffer preserves data up to the block size specified by the *Block Size* register. Following definitions of controlling buffer enable the Host Driver to access the *Buffer Data Port* register repeatedly with 32-bit width regardless of block size.

In case of write operation, the buffer accumulates the data written through the *Buffer Data Port* register. When the buffer pointer reaches the block size, **Buffer Write Enable** in the *Present State* register changes 1 to 0. It means no more data can be written to the buffer. Excess data of the last write is ignored. For example, if just lower 2 bytes data can be written to the buffer and a 32-bit (4-byte) block of data is written to the *Buffer Data Port* register, the lower 2 bytes of data is written to the buffer and the upper 2 bytes is ignored. Every time **Buffer Write Enable** changes 0 to 1, it means a next block of data can be written to the buffer. A new blocks write shall always start from BE[00] position. After that, a block of data can be written to the buffer without checking **Buffer Write Enable**.

In case of read operation, every time **Buffer Read Enable** in the *Present State* register changes 0 to 1, a block of data can be read through the *Buffer Data Port* register. A new block read shall always start from BE[00] position. After that a block of data can be read from the buffer without checking **Buffer Read Enable**. Excess data of the last read is ignored. For example, if just lower 2 bytes of data are left in the buffer and a 32-bit (4-byte) read is performed, the lower 2 bytes is valid but the upper 2 bytes is undefined. When the buffer pointer reaches block size, **Buffer Read Enable** changes 1 to 0. It means no more data can be read from the buffer.

Implementation Note:

Table 1-4 implies that the Host Driver should align register accesses on address boundaries matching the number of bytes in the access. That is, single byte accesses may be aligned on any offset within the register set; word (double byte) accesses should be aligned on two-byte offsets; and double-word (quad byte) accesses should be aligned on four-byte offsets. According to the feature (3), the Host Driver can always access *Buffer Data Port* register with double-word access.

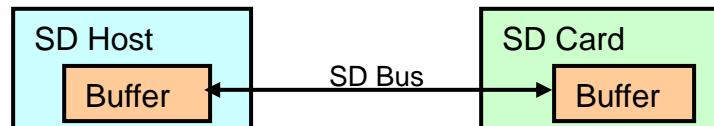
1.7.2 Determining Buffer Block Length**Figure 1-5 : Buffer Size Relation between Host and Card**

To be able to transfer blocks of data at a burst, the relationship between Host Controller and SD card buffer sizes is important. The Host Driver shall use the same data block length for both the Host Controller and the card. If the controller and card buffer sizes are different, the Host Driver shall use the smaller value. The maximum Host Controller buffer size is defined by the **Max Block Length** field in the *Capabilities* register.

Implementation Note:

The card buffer size is described as maximum block length in the Card Specific Data (CSD) register for memory cards (for cards compliant with the Physical Layer Specification, READ_BL_LEN and WRITE_BL_LEN shall be the same) and in the Card Information Structure (CIS) for SDIO cards. Physical Layer Specification re-defines that maximum block length is only used to calculate capacity of memory card. Even though it indicates larger than 512 bytes, block length shall be set to 512 byte for data transfer. This is because 512 bytes block length is required to keep compatibility with 512 bytes data boundary. If the SDIO card has multiple buffers, the block size in CIS indicates the size of the smallest buffer; this is the value the Host Driver should use when programming block size. Buffer information (for example, buffer port address) in the SDIO card is function specific.

1.7.3 Dividing Large Data Transfer

The SDIO command CMD53 definition limits the maximum data size of data transfers according to the following formula:

Max data size = Block size x Block count

For example, Block size is specified by the buffer size as described in 1.7.2 and the block count can be a maximum of 512 (9-bit count) as specified in the command argument for CMD53. In the worst case, if the card has only a 1 byte buffer, up to 512 bytes of data can be transferred using CMD53 (Block Size =1, Block Count = 512). If the card does not support multiple-block mode, only one byte can be transferred in this case. If an application or Card Driver wants to transfer larger sizes of data, the Host Driver shall divide large data into multiple CMD53 blocks.

1.8 Relationship between Interrupt Control Registers

The Host Controller implements a number of interrupt sources. Interrupt sources can be enabled as interrupts or as system wakeup signals as shown in Figure 1-6. If the interrupt source's corresponding bit in the *Normal Interrupt Status Enable* or *Error Interrupt Status Enable* register is 1 and the interrupt becomes active its active state is latched and made available to the Host Driver in the *Normal Interrupt Status* register or the *Error Interrupt Status* register. Interrupt Status shall be cleared when *Interrupt Status Enable* is cleared. (This is not expressed in the Figure 1-6.)

An interrupt source with its bit set in an interrupt status register shall assert a system interrupt signal if its corresponding bit is also set in the *Normal Interrupt Signal Enable* register or the *Error Interrupt Signal Enable* register. Once signaled, most interrupts are cleared by writing a 1 to the associated bit in the interrupt status register. Card interrupts, however, shall be cleared by the Card Driver. If the Card Interrupt is generated, the Host Driver may clear Card Interrupt Status Enable to disable card interrupts while the Card Driver is processing them. After all interrupt sources are cleared, the Host Driver sets it again to enable another card interrupt. Disabling the Card Interrupt Status Enable avoids generating multiple interrupts during processing interrupt service.

The *Wakeup Control* register enables **Card Interrupt**, **Card Insertion**, or **Card Removal** status changes to be configured to generate a system wakeup signal. These interrupts are enabled or masked independently of the *Normal Interrupt Signal Enable* register. The kind of wakeup event can be read from the *Normal Interrupt Status* register.

The interrupt signal and wakeup signal are logical ORed and shall be read from the *Slot Interrupt Status* register.

Implementation Note:

The Host Driver is responsible for enabling wakeup signals and disabling interrupt signals when the Host System goes into its sleep mode, and for disabling wakeup signals and enabling interrupt signals when the Host System goes into run mode. The Host Driver should not enable both at the same time.

Implementation Note:

The Host Systems may implement interrupt and wakeup signals in various ways. For example, the PCI bus supports **PME#**, which can be asserted without PCI clock, then interrupts use **INTx#** and wakeups use **PME#**. Alternatively, the system may use an ORed signal of interrupt and wakeup if the system bus supports one interrupt line to the Host Controller.

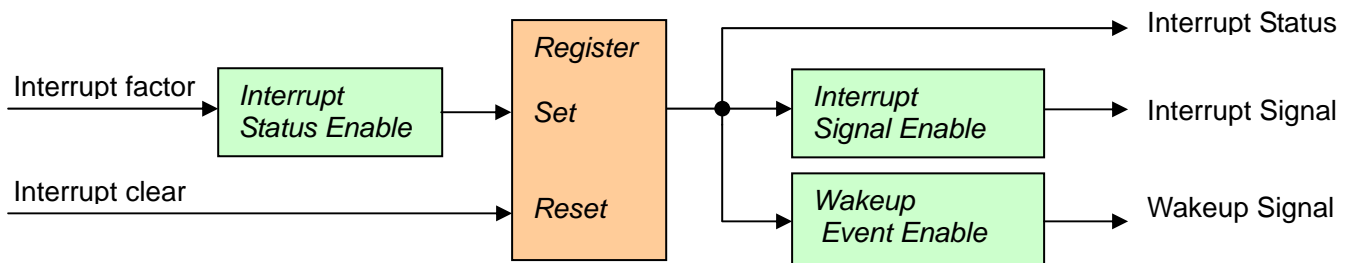

Figure 1-6 : Logical Relation for Interrupt Registers

Interrupt Status Enable	Interrupt Signal Enable	Wakeup Event Enable	Interrupt Status	Interrupt Signal
0 (Mask)	x (don't care)	x (don't care)	0 (Not exist)	0 (De-assert)
1 (Enable)	0 (Mask)	x (don't care)	x (don't care)	0 (De-assert)
1 (Enable)	1 (Enable)	x (don't care)	0 (Not exist)	0 (De-assert)
1 (Enable)	1 (Enable)	x (don't care)	1 (Exist)	1 (Assert)

Table 1-5 : Interrupt Signal Table

Interrupt Status Enable	Interrupt Signal Enable	Wakeup Event Enable	Interrupt Status	Wakeup Signal
0 (Mask)	x (don't care)	x (don't care)	0 (Not exist)	0 (De-assert)
1 (Enable)	x (don't care)	0 (Mask)	x (don't care)	0 (De-assert)
1 (Enable)	x (don't care)	1 (Enable)	0 (Not exist)	0 (De-assert)
1 (Enable)	x (don't care)	1 (Enable)	1 (Exist)	1 (Assert)

Table 1-6 : Wakeup Signal Table

Implementation Note: The Host Controller may implement asserted wakeup or interrupt signals as active high or active low.

1.9 HW Block Diagram and Timing Part

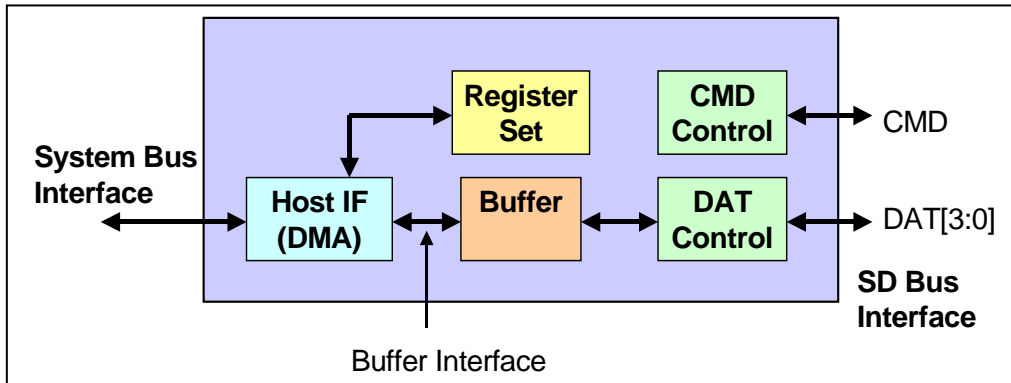

Figure 1-7 : Block Diagram of Host Controller

The Host Controller has two bus interfaces, the System Bus Interface and the SD Bus Interface. The Host Controller assumes that these interfaces are asynchronous (that is, are working on different clock frequencies). The Host Driver is on system bus time (because it is software executed by the Host Controller CPU, on its system clock). The SD card is on SD Bus time (that is, its operation is synchronized by **SDCLK**). The Host Controller shall synchronize signals to communicate between these interfaces. Blocks of data shall be synchronized at the buffer module. All status registers shall be synchronized by the system clock and maintain synchronization during output to the system interface. Control registers, which trigger SD Bus transactions, shall be synchronized by **SDCLK**. Therefore, there will be a timing delay when propagating signals between the two interfaces. This means the Host Driver cannot do real time control of the SD Bus and needs to rely on the Host Controller to control the SD Bus according to register settings.

The Buffer Interface enables internal read and write buffers (Refer to use of the **Buffer Read Enable** and **Buffer Write Enable** in the *Present State* register as described in section 1.7 "Buffer Control"). The **Transfer Complete** interrupt status indicates completion of the read / writes transfer for both DMA and non DMA transfers. However, the timing is different between reads and writes. Read transfers shall be completed after all valid data have been transferred to the Host System and are ready for the Host Driver to access. Write transfers shall be completed after all valid data have been transferred to the SD card and the busy state is over.

Table 1-7 shows the relation between statuses and interrupts for data transfer.

Type of Data transfer	Buffer Status	Buffer Interrupt	Complete Interrupt
Write Transfer (Non DMA)	Buffer Write Enable	Buffer Write Ready	Transfer Complete
Write Transfer (DMA)	(Driver ignores)	(Driver ignores)	Transfer Complete
Read Transfer (Non DMA)	Buffer Read Enable	Buffer Read Ready	Transfer Complete
Read Transfer (DMA)	(Driver ignores)	(Driver ignores)	Transfer Complete

Table 1-7 : Summary of Register Status for Data Transfer

1.10 Power State Definition of SD Host Controller

Implementation Note: Table 1-8 defines controller power states, which are listed in increasing order of power consumption. The Host Controller should reduce the power consumption by using these conditions.

SD Card	Internal Clock *1	SD Power	SD Clock	SD Bus	Power State *2	Comment
No exist	Stop	OFF	Stop	-	P00	Host not used
	Oscillate	OFF	Stop	-	P01	No card
	Oscillate	ON	Stop	-	P02	Short transition state *3
	Oscillate	ON	Oscillate	-	P03	Short transition state *3
Exist	Stop	OFF	Stop	-	P10	Host not used
	Oscillate	OFF	Stop	-	P11	Low power mode
	Oscillate	ON	Stop	-	P12	Wakeup
	Oscillate	ON	Oscillate	Wait	P13	Ready to issue command
	Oscillate	ON	Oscillate	Access	P14	During transaction

Table 1-8 : Power State Definition

Implementation Note:

*1: Internal clock should be stopped when the Host System does not use the Host Controller.

*2: Power states are not actually implemented in Host Controller. This label is for reference.

*3: Short transition state: Temporary power states. The Host Controller automatically goes to P01 when it detects No Card.

The SD Clock shall not be supplied when card power is OFF.

States described in Table 1-8 can be determined by reading the corresponding register bits:

Internal clock oscillate/stop	Internal Clock Enable in the <i>Clock Control</i> register
SD Card : Exist/Not exist	Card Inserted in the <i>Present State</i> register
SD Power : ON/OFF	SD Bus Power in the <i>Power Control</i> register
SD Clock : oscillate/stop	SD Clock Enable in the <i>Clock Control</i> register
SD Bus : access/wait (idle)	Command Inhibit (CMD) and Command Inhibit (DAT) in the <i>Present State</i> register

1.11 Auto CMD12

Multiple block transfers for SD memory require CMD12 to stop the transactions. The Host Controller automatically issues CMD12 when the last block transfer is completed. This feature of the Host Controller is called Auto CMD12. The Host Driver should set **Auto CMD12 Enable** in the *Transfer Mode* register when issuing a multiple block transfer command. Auto CMD12 timing synchronization with the last data block shall be done by hardware in the Host Controller. Commands that do not use the DAT line can be issued during multiple block transfers. These commands are referred to using the notation CMD_wo_DAT.

In order to prevent DAT line commands and CMD_wo_DAT commands from conflicting, the Host Controller shall arbitrate the timing by which each command is issued on the SD Bus. Therefore, a command might not immediately be issued after the Host Driver writes to the *Command* register. The command may be issued before or after Auto CMD12, depending on the timing. To be able to distinguish the responses of DAT line and CMD_wo_DAT commands, the Auto CMD12 response can be determined from the upper four bytes of the *Response* register (at offset 01Ch in the standard register set).

If errors are detected related to Auto CMD12, the Host Controller shall issue an **Auto CMD Error** interrupt. The Host Driver can check the Auto CMD12 error status (Command Index/End bit/CRC/Timeout Error) by reading the *Auto CMD Error Status* register.

The Table 1-9 illustrates the relationship between Auto CMD12 errors and any CMD_wo_DAT commands that have been issued by the Host Driver.

Relation of the commands	Error Status	Comments
Auto CMD12 only	CMD_wo_DAT : Unrelated Auto CMD12 : Error	Only Auto CMD12 is issued, therefore Auto CMD12 is failed.
CMD_wo_DAT before Auto CMD12	CMD_wo_DAT : No Error Auto CMD12 : Error	CMD_wo_DAT successful, but Auto CMD12 failed.
CMD_wo_DAT before Auto CMD12	CMD_wo_DAT : Error Auto CMD12 : Not executed	CMD_wo_DAT is failed, therefore Auto CMD12 could not be issued.
Auto CMD12 before CMD_wo_DAT	CMD_wo_DAT : Not executed Auto CMD12 : Error	Auto CMD12 is failed, therefore CMD_wo_DAT could not be issued.

Table 1-9 : Relation between Auto CMD12 and CMD_wo_DAT

The Host Driver may determine which of these error cases has occurred by checking the *Auto CMD Error Status* register when an **Auto CMD Error** interrupt occurs. If the Auto CMD12 was not executed, the Host Driver needs to recover from the CMD_wo_DAT error and issue CMD12 to stop the multiple block transfer. If the CMD_wo_DAT was not executed, the Host Driver can issue it again after recovering from the Auto CMD12 error. The procedures for recovering from error interrupts and from Auto CMD12 errors are described in sections 3.10.1 and 3.10.2.

In UHS mode SDR104 (Refer to Section 2.2.24 *Host Control 2* register), Host Driver shall use Auto CMD23 to stop multiple block read / write operation instead of using Auto CMD12. In the other bus speed mode, if the card supports CMD23, Host Driver should use Auto CMD23 instead of using CMD12.

1.12 Controlling SDCLK

Table 1-10 shows how **SDCLK** is controlled by the **SD Bus Power** in the *Power Control* register and the **SD Clock Enable** in the *Clock Control* register.

The Clock Period of **SDCLK** is specified by the **SDCLK Frequency Select** in the *Clock Control* register and the **Base Clock Frequency For SD Clock** in the *Capabilities* register. Because of the SD card may use both clock edges, the duty of SD clock should be average 50% (scattering within 45-55%) and the Period of High should be half of the Clock Period. The oscillation of **SDCLK** starts from driving specified Period of High. When **SDCLK** is stopped by the **SD Clock Enable**, the Host Controller shall stop **SDCLK** after driving Period of High to maintain clock duty. When **SDCLK** is stopped by the **SD Bus Power**, the Host Controller shall stop **SDCLK** immediately (drive Low) and **SD Clock Enable** should be cleared.

SD Bus Power (Note 1)	SD Clock Enable (Note 2)	State of SDCLK
Change 0 to 1	0	Drive Low
	1	Start Clock with specified Period of High
Change 1 to 0	0	Drive Low
	1	Drive Low immediately
0	Don't Care	Drive Low
1	Change 0 to 1	Start Clock with specified Period of High
	Change 1 to 0	Maintains Period of High and then stops Clock and drive Low

Table 1-10 : Controlling SDCLK by the SD Bus Power and SD Clock Enable

Note 1: When the card state is changed from Debouncing to No Card, the Host Controller shall clear the **SD Bus Power**.

Note 2: When the the card state is changed from Card Inserted to Debouncing, the Host Controller shall clear the **SD Clock Enable** immediately.

If Host Controller supports shared bus, each device is selected by clock output pins and specific clock control is required. Refer to Shared Bus Control register for more detail.

1.13 Advanced DMA

SD Host Controller Standard Specification Version 2.00 defines the ADMA (Advanced DMA) transfer algorithm. The DMA algorithm defined in the SD Host Controller Standard Specification Version 1.00 is called SDMA (Single Operation DMA). SDMA had disadvantage that **DMA Interrupt** generated at every page boundary disturbs CPU to reprogram the new system address. This SDMA algorithm forms a performance bottleneck by interruption at every page boundary. ADMA adopts scatter gather DMA algorithm so that higher data transfer speed is available. The Host Driver can program a list of data transfers between system memory and SD card to the Descriptor Table before executing ADMA. It enables ADMA to operate without interrupting the Host Driver. Furthermore, ADMA can support not only 32-bit system memory addressing but also 64-bit system memory addressing. The 32-bit system memory addressing uses lower 32-bit field of 64-bit address registers. Support of SDMA and ADMA are optional for the Host Controller.

There are two types of ADMA; ADMA1 and ADMA2. ADMA1 can support data transfer of only 4KB aligned data in system memory. ADMA2 improves the restriction so that data of any location and any size can be transferred in system memory. The format of Descriptor Table is different between them. The Host Controller Specification Ver2.00 defines ADMA2 as standard ADMA and recommends supporting ADMA2 rather than ADMA1. DMA mode ADMA1 is not supported in Standard Host Controller versions 3.0 and latter. When the term "ADMA" is used in this document, it means ADMA2.

1.13.1 Block Diagram of ADMA2

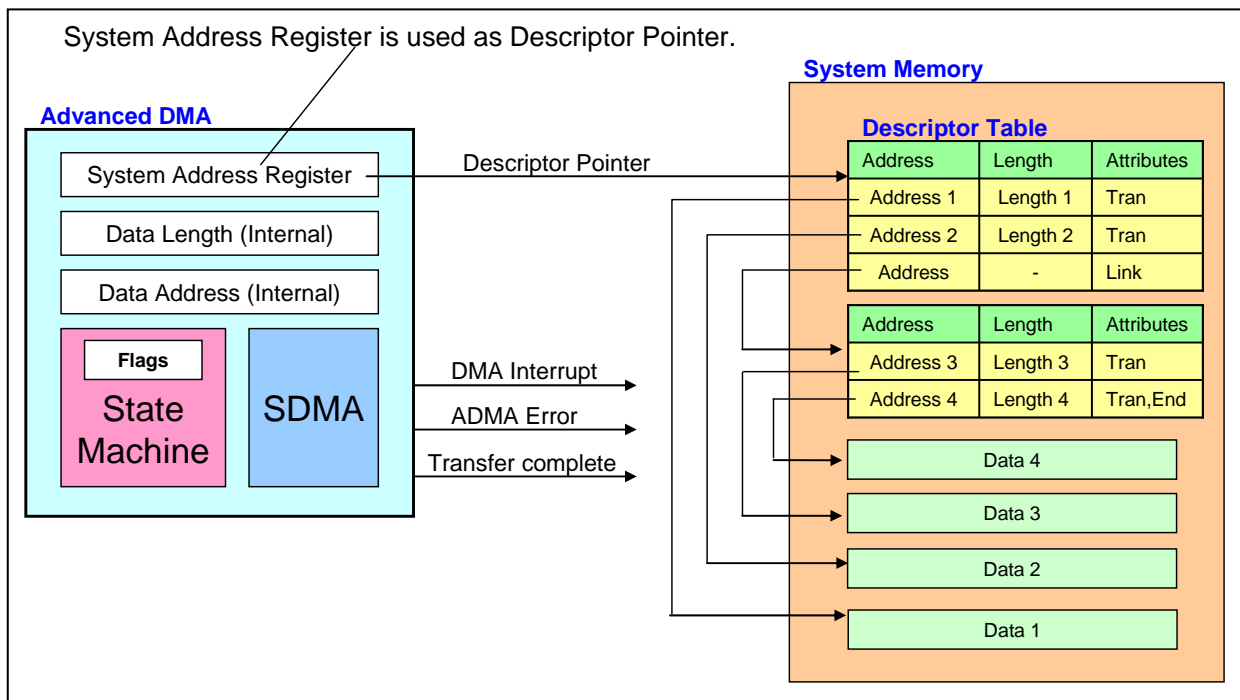

Figure 1-8 : Block Diagram of ADMA2

Figure 1-8 shows block diagram of ADMA2. The Descriptor Table is created in system memory by the Host Driver. 32-bit Address Descriptor Table is used for the system with 32-bit addressing and 64-bit Address Descriptor Table is used for the system with 64-bit addressing. Each descriptor line (one executable unit) consists with address, length and attribute field. The attribute specifies operation of the descriptor line. ADMA2 includes SDMA, State Machine and Registers circuits. ADMA2 does not use

SD Host Controller Simplified Specification Version 3.00

32-bit *SDMA System Address* Register (offset 0) but uses the 64-bit *Advanced DMA System Address* register (offset 058h) for descriptor pointer. Writing Command register triggers off ADMA2 transfer. ADMA2 fetches one descriptor line and execute it. This procedure is repeated until end of descriptor is found (End=1 in attribute).

1.13.2 An Example of ADMA2 Programming

Figure 1-9 : An Example of ADMA2 Data Transfer

Figure 1-9 shows a typical ADMA2 descriptor program. The Host Driver describes the Descriptor Table with each slice is placed somewhere in contiguous system memory. The Host Driver describes the Descriptor Table with set of address, length and attributes. Each sliced data is transferred in turns as programmed in descriptor.

1.13.3 Data Address and Data Length Requirements

There are 3 requirements to program the descriptor.

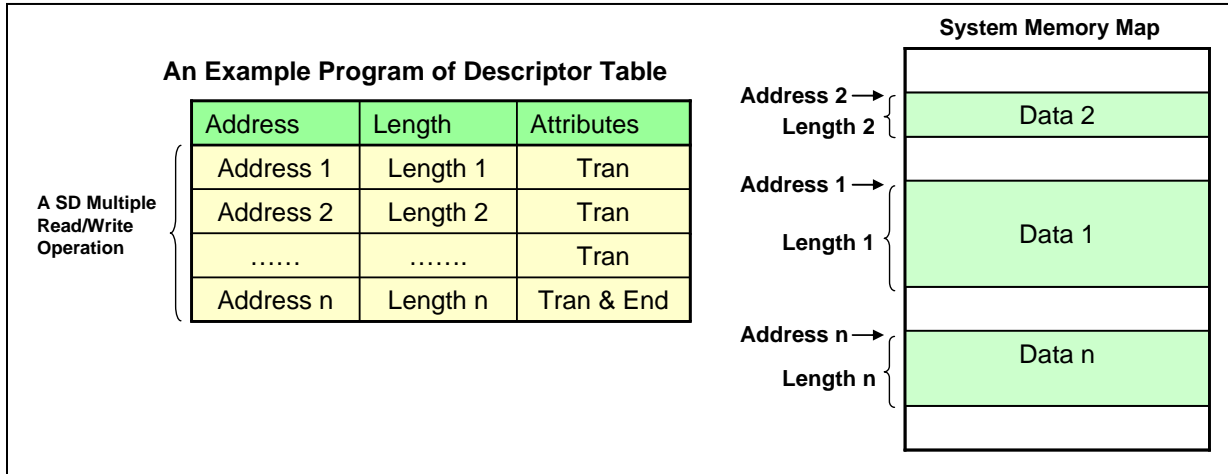
The minimum unit of address is 4 bytes.

The maximum data length of each descriptor line is less than 64KB.

Total Length = Length 1 + Length 2 + Length 3 + ... + Length n
= multiple of Block Size

If total length of a descriptor were not multiple of block size, ADMA2 transfer might not be terminated. In this case, the transfer should be aborted by data timeout.

Block Count register limits the maximum of 65535 blocks transfer. If ADMA2 operation is less than or equal 65535 blocks transfer, *Block Count* register can be used. In this case, total length of Descriptor Table shall be equivalent to multiply block size and block count. If ADMA2 operation is more than 65535 blocks transfer, *Block Count* Register shall be disabled by setting 0 to **Block Count Enable** in the *Transfer Mode* Register. In this case, length of data transfer is not designated by block count but Descriptor Table. Therefore, the timing of detecting the last block on SD bus may be different and it affects the control of **Read Transfer Active**, **Write Transfer Active** and **DAT line Active** in the *Present State* register. In case of read operation, several blocks may be read more than required. The Host Driver shall ignore out of range error if the read operation is for the last block of memory area.

1.13.4 Descriptor Table

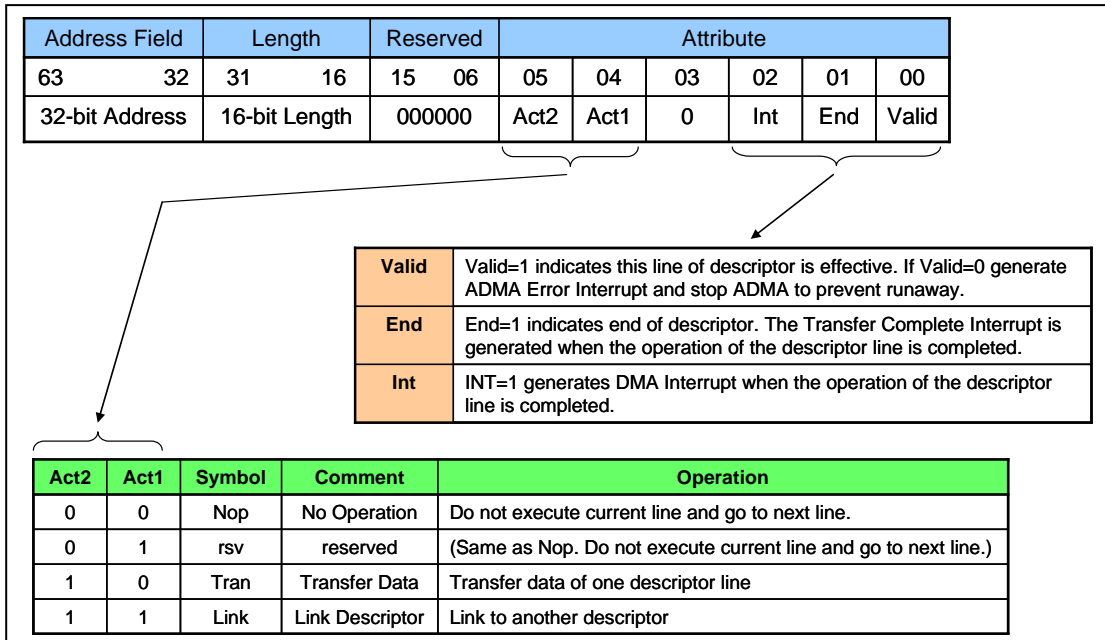

Figure 1-10 : 32-bit Address Descriptor Table

Figure 1-10 shows the definition of 32-bit Address Descriptor Table. One descriptor line consumes 64-bit (8-byte) memory space. Attribute is used to control descriptor. 3 action symbols are specified. "Nop" operation skips current descriptor line and fetches next one. "Tran" operation transfers data designated by address and length field. "Link" operation is used to connect separated two descriptors. The address field of link points to next Descriptor Table. The combination of Act2=0 and Act1=1 is reserved and defined the same operation as Nop. A future version of controller may use this field and redefine a new operation. 32-bit address is stored in the lower 32-bit of 64-bit address registers. Address field shall be set on 32-bit boundary (Lower 2-bit is always set to 0) for 32-bit address descriptor table. Table 1-11 shows the definition of length field in the Descriptor Table.

Length Field	Value of Length
0000h	65536 bytes
0001h	1 byte
0002h	2 bytes
.....
FFFFh	65535 bytes

Table 1-11 : ADMA2 Length Field

64-bit Descriptor is removed from the Simplified Specification because 64-bit system supported will be modified by the Host Controller Specification Version 4.00.

Table 1-12 : 64-bit Address Descriptor Table (Removed)

SD Host Controller Simplified Specification Version 3.00

1.13.5 ADMA2 States

Figure 1-11 shows state diagram of ADMA2. 4 states are defined; Fetch Descriptor state, Change Address state, Transfer Data state, and Stop ADMA state. Operation of each state is explained in Table 1-13.

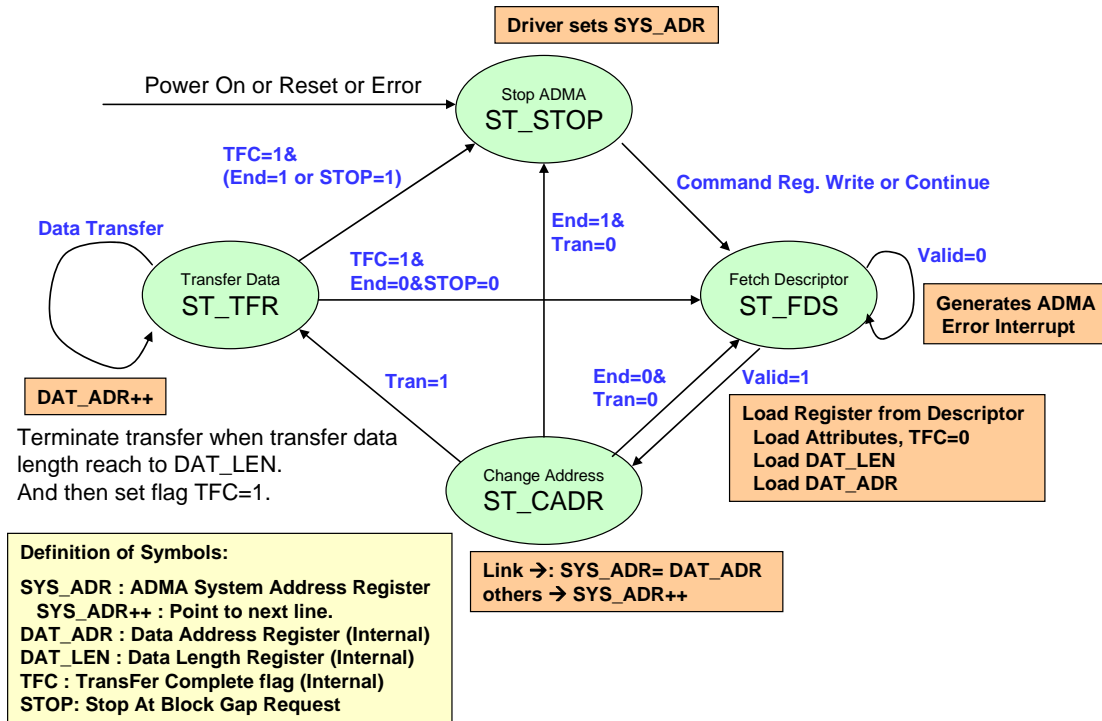

Figure 1-11 : State Diagram of the ADMA2

State Name	Operation
ST_FDS (Fetch Descriptor)	ADMA2 fetches a descriptor line and set parameters in internal registers. Next go to ST_CADR state.
ST_CADR (Change Address)	Link operation loads another Descriptor address to ADMA System Address register. In other operations, ADMA System Address register is incremented to point next descriptor line. If End=0, go to ST_TFR state. ADMA2 shall not be stopped at this state even if some errors occur.
ST_TFR (Transfer Data)	Data transfer of one descriptor line is executed between system memory and SD card. If data transfer continues (End=0) go to ST_FDS state. If data transfer completes, go to ST_STOP state.
ST_STOP (Stop DMA)	ADMA2 stays in this state in following cases: (1) After Power on reset or software reset. (2) All descriptor data transfers are completed If a new ADMA2 operation is started by writing Command register, go to ST_FDS state.

Table 1-13 : ADMA2 States

ADMA2 does not support suspend / resume function but stop and continue are available. When the **Stop At Block Gap Request** in the *Block Gap Control* register is set during the ADMA2 operation, the **Block Gap Event Interrupt** is generated when ADMA2 is stopped at block gap. The Host Controller shall stop ADMA2 read operation by using Read Wait or stopping SD Clock. While stopping ADMA2, any SD commands cannot be issued. (In case of Host Controller version 1.00, the **Stop At Block Gap Request** can be set only when the card supports the Read Wait.)

Error occurrence during ADMA2 transfer may stop ADMA2 operation and generate an **ADMA Error Interrupt**. The **ADMA Error State** field in the *ADMA Error Status* register holds state of ADMA2 stopped. The host driver can identify the error descriptor location by the following method: If ADMA stopped at ST_FDS state, the *ADMA System Address Register* points the error descriptor line. If ADMA stopped at ST_TFR or ST_STOP state, the *ADMA System Address Register* points the next location of error descriptor line. By this reason, ADMA2 shall not stop at ST_CADR state.

1.14 Test Registers

The test registers are defined for testing purpose. When it is difficult to generate some interrupts intentionally, this feature can be used to generate these interrupts manually for driver debugging. The *Force Event* register to control the *Error Interrupt Status* and *Auto CMD Error Status* are defined for this purpose. Intentional control of card insertion and removal are also difficult. The **Card Detect Signal Selection** and **Card Detect Test Level** in the *Host Control 1* register enable manual control of **Card Inserted** in the *Present State* register and generating interrupt of **Card Insertion** and **Card Removal** in the *Normal Interrupt Status* register. Support of the test registers is mandatory.

1.15 Block Count

Set Block Count Command (CMD23) is defined by the Physical Layer Specification Version 3.00. It provides timing free method to stop a multiple block operation. A block count is set in the argument of CMD23 to specify a transfer length of following CMD18 or CMD25.

Auto CMD23 is a feature that automatically issues a CMD23 before a CMD18 or CMD25 is sent. Objective of this function is to avoid performance deterioration during memory access by removing the interrupt service of CMD23. Offset 008h *Argument 1* register is used for CMD18 or CMD25. Then offset 000h is assigned for *Argument 2* register for CMD23. The Host Controller does not use *Argument 2* register for counting data transfer length. SDMA is not intended to use Auto CMD23. ADMA and Non-ADMA transfer can use Auto CMD23.

Data length of a data transfer operation for host side is determined as described in Table 1-14. There are two cases; Non-ADMA and ADMA. Total length of AMDA Descriptor means that sum of 16-bit data length for each line of an ADMA descriptor. **Block Count Enable** should be disabled for ADMA. It is important note that a total data transfer length for Host Controller shall be equivalent to that of card.

Transfer Mode	Block Count Enable	Data Length
Non ADMA	1	Block Count Register Value
ADMA	0	Total length of AMDA Descriptor

Table 1-14 : Host Controller Data Transfer Length

1.16 Sampling Clock Tuning

In UHS-I mode, the SD bus can be operating in high clock frequency mode and then the data window from the card on CMD and DAT[3:0] lines gets smaller. The position of the data window will vary depending on the card and host system implementation. Therefore, the Host Controller shall support a tuning circuit when SDR104 or SDR50 (if **Use Tuning for SDR50** is set to 1 in the *Capabilities* register) is supported by executing the tuning procedure defined by Figure 2-29, and adjusting the sampling clock. **Execute Tuning** and **Sampling Clock Select** in the *Host Control 2* register are used to control the tuning circuit.

2. SD Host Standard Register

2.1 Summary of register set

2.1.1 SD Host Control Register Map

Table 2-1 summarizes the standard SD Host Controller register set. The Host Driver needs to determine the base address of the register set by a Host System specific method. The register set is 256 bytes in size. For multiple slot controllers, one register set is assigned per each slot, but the registers at offsets 0F0h-0FFh are assigned as a common area. These registers contain the same values for each slot's register set.

Offset	15-08 bit	07-00 bit	Offset	15-08 bit	07-00 bit
002h	SDMA System Address (High) Argument 2 (High)		000h	SDMA System Address (Low) Argument 2 (Low)	
006h	Block Count		004h	Block Size	
00Ah	Argument 1 (High)		008h	Argument 1 (Low)	
00Eh	Command		00Ch	Transfer Mode	
012h	Response1		010h	Response0	
016h	Response3		014h	Response2	
01Ah	Response5		018h	Response4	
01Eh	Response7		01Ch	Response6	
022h	Buffer Data Port1		020h	Buffer Data Port0	
026h	Present State		024h	Present State	
02Ah	Wakeup Control	Block Gap Control	028h	Power Control	Host Control 1
02Eh	Software Reset	Timeout Control	02Ch	Clock Control	
032h	Error Interrupt Status		030h	Normal Interrupt Status	
036h	Error Interrupt Status Enable		034h	Normal Interrupt Status Enable	
03Ah	Error Interrupt Signal Enable		038h	Normal Interrupt Signal Enable	
03Eh	Host Control 2		03Ch	Auto CMD Error Status	
042h	Capabilities		040h	Capabilities	
046h	Capabilities		044h	Capabilities	
04Ah	Maximum Current Capabilities		048h	Maximum Current Capabilities	
04Eh	Maximum Current Capabilities (Reserved)		04Ch	Maximum Current Capabilities (Reserved)	
052h	Force Event for Error Interrupt Status		050h	Force Event for Auto CMD Error Status	
056h	---		054h	---	ADMA Error Status
05Ah	ADMA System Address [31:16]		058h	ADMA System Address [15:00]	
05Eh	ADMA System Address [63:48]		05Ch	ADMA System Address [47:32]	
062h	Preset Value		060h	Preset Value	
066h	Preset Value		064h	Preset Value	
06Ah	Preset Value		068h	Preset Value	
06Eh	Preset Value		06Ch	Preset Value	
---	---		---	---	
0E2h	Shared Bus Control (High)		0E0h	Shared Bus Control (Low)	
---	---		---	---	
0F2h	---		0F0h	---	
---	---		---	---	
0FEh	Host Controller Version		0FCh	Slot Interrupt Status	

Table 2-1 : SD Host Controller Register Map

2.1.2 Configuration Register Types

Configuration register fields are assigned one of the attributes described below:

Register Attribute	Description
RO	Read-only register: Register bits are read-only and cannot be altered by software or any reset operation. Writes to these bits are ignored.
ROC	Read-only status: These bits are initialized to zero at reset. Writes to these bits are ignored.
RW	Read-Write register: Register bits are read-write and may be either set or cleared by software to the desired state.
RW1C	Read-only status, Write-1-to-clear status: Register bits indicate status when read, a set bit indicating a status event may be cleared by writing a 1. Writing a 0 to RW1C bits has no effect.
RWAC	Read-Write, automatic clear register: The Host Driver requests a Host Controller operation by setting the bit. The Host Controllers shall clear the bit automatically when the operation of complete. Writing a 0 to RWAC bits has no effect.
Hwlnit	Hardware Initialized: Register bits are initialized by firmware or hardware mechanisms such as pin strapping or serial EEPROM. Bits are read-only after initialization, and writes to these bits are ignored.
Rsvd	Reserved. These bits are initialized to zero, and writes to them are ignored.
WO	Write-only register. It is not physically implemented register. Rather, it is an address at which registers can be written.

Table 2-2 : Register (and Register Bit-Field) Types

Implementation Note: If the Host Driver writes to RO, ROC, Hwlnit and Rsvd bits, the Host Driver should write these bits as zero to avoid possible compatibility problems with future versions of this specification.

2.1.3 Register Initial Values

The Host Controller shall set all registers to their initial values at power-on reset. Initial values of the register are defined as follows. All other registers' default value shall be all bits set to zero. Value of the Capabilities register and Maximum Current Capabilities register depends on the Host Controller. Value of the Host Controller Version register depends on the Host Controller.

2.1.4 Reserved Bits of Register

"Reserved" means the bit can be defined for future use and is currently set to 0. These bits should be written as zero.

2.2 SD Host Standard Register

2.2.1 SDMA System Address / Argument 2 Register (Offset 000h)

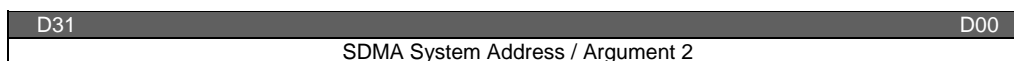

Figure 2-1 : SDMA System Address / Argument 2 Register

Location	Attrib	Register Field Explanation
31-00	RW	<p>SDMA System Address / Argument 2 This register contains the physical system memory address used for DMA transfers or the second argument for the Auto CMD23.</p> <p>(1) SDMA System Address This register contains the system memory address for a SDMA transfer. When the Host Controller stops a SDMA transfer, this register shall point to the system address of the next contiguous data position. It can be accessed only if no transaction is executing (i.e., after a transaction has stopped). Read operations during transfers may return an invalid value. The Host Driver shall initialize this register before starting a SDMA transaction. After SDMA has stopped, the next system address of the next contiguous data position can be read from this register. The SDMA transfer waits at the every boundary specified by the Host SDMA Buffer Boundary in the <i>Block Size</i> register. The Host Controller generates DMA Interrupt to request the Host Driver to update this register. The Host Driver sets the next system address of the next data position to this register. When the most upper byte of this register (003h) is written, the Host Controller restarts the SDMA transfer. When restarting SDMA by the Resume command or by setting Continue Request in the <i>Block Gap Control</i> register, the Host Controller shall start at the next contiguous address stored here in the <i>SDMA System Address</i> register. ADMA does not use this register.</p> <p>(2) Argument 2 This register is used with the Auto CMD23 to set a 32-bit block count value to the argument of the CMD23 while executing Auto CMD23. If Auto CMD23 is used with ADMA, the full 32-bit block count value can be used. If Auto CMD23 is used without AMDA, the available block count value is limited by the <i>Block Count</i> register. 65535 blocks is the maximum value in this case.</p>

Table 2-3 : SDMA System Address / Argument 2 Register

2.2.2 Block Size Register (Offset 004h)

This register is used to configure the number of bytes in a data block.

D15	D14	D12	D11	D00
Rsvd	Host SDMA Buffer Boundary		Transfer Block Size	

Figure 2-2 : Block Size Register

Location	Attrib	Register Field Explanation																								
15	Rsvd	Reserved																								
14-12	RW	<p>Host SDMA Buffer Boundary</p> <p>The large contiguous memory space may not be available in the virtual memory system. To perform long SDMA transfer, <i>SDMA System Address</i> register shall be updated at every system memory boundary during SDMA transfer. These bits specify the size of contiguous buffer in the system memory. The SDMA transfer shall wait at the every boundary specified by these fields and the Host Controller generates the DMA Interrupt to request the Host Driver to update the <i>SDMA System Address</i> register. At the end of transfer, the Host Controller may issue or may not issue DMA Interrupt. In particular, DMA Interrupt shall not be issued after Transfer Complete Interrupt is issued. In case of this register is set to 0 (buffer size = 4K bytes), lower 12-bit of byte address points data in the contiguous buffer and the upper 20-bit points the location of the buffer in the system memory. The SDMA transfer stops when the Host Controller detects carry out of the address from bit 11 to 12. These bits shall be supported when the SDMA Support in the <i>Capabilities</i> register is set to 1 and this function is active when the DMA Enable in the <i>Transfer Mode</i> register is set to 1. ADMA does not use this register.</p> <table border="1"> <tbody> <tr> <td>000b</td> <td>4K bytes</td> <td>(Detects A11 carry out)</td> </tr> <tr> <td>001b</td> <td>8K bytes</td> <td>(Detects A12 carry out)</td> </tr> <tr> <td>010b</td> <td>16K Bytes</td> <td>(Detects A13 carry out)</td> </tr> <tr> <td>011b</td> <td>32K Bytes</td> <td>(Detects A14 carry out)</td> </tr> <tr> <td>100b</td> <td>64K bytes</td> <td>(Detects A15 carry out)</td> </tr> <tr> <td>101b</td> <td>128K Bytes</td> <td>(Detects A16 carry out)</td> </tr> <tr> <td>110b</td> <td>256K Bytes</td> <td>(Detects A17 carry out)</td> </tr> <tr> <td>111b</td> <td>512K Bytes</td> <td>(Detects A18 carry out)</td> </tr> </tbody> </table>	000b	4K bytes	(Detects A11 carry out)	001b	8K bytes	(Detects A12 carry out)	010b	16K Bytes	(Detects A13 carry out)	011b	32K Bytes	(Detects A14 carry out)	100b	64K bytes	(Detects A15 carry out)	101b	128K Bytes	(Detects A16 carry out)	110b	256K Bytes	(Detects A17 carry out)	111b	512K Bytes	(Detects A18 carry out)
000b	4K bytes	(Detects A11 carry out)																								
001b	8K bytes	(Detects A12 carry out)																								
010b	16K Bytes	(Detects A13 carry out)																								
011b	32K Bytes	(Detects A14 carry out)																								
100b	64K bytes	(Detects A15 carry out)																								
101b	128K Bytes	(Detects A16 carry out)																								
110b	256K Bytes	(Detects A17 carry out)																								
111b	512K Bytes	(Detects A18 carry out)																								

SD Host Controller Simplified Specification Version 3.00

11-00	RW	<p>Transfer Block Size</p> <p>This register specifies the block size of data transfers for CMD17, CMD18, CMD24, CMD25, and CMD53. Values ranging from 1 up to the maximum buffer size can be set. In case of memory, it shall be set up to 512 bytes (Refer to Implementation Note in Section 1.7.2). It can be accessed only if no transaction is executing (i.e., after a transaction has stopped). Read operations during transfers may return an invalid value, and write operations shall be ignored.</p> <table border="1" data-bbox="456 443 813 779"> <tr> <td>0800h</td> <td>2048 Bytes</td> </tr> <tr> <td>...</td> <td>...</td> </tr> <tr> <td>0200h</td> <td>512 Bytes</td> </tr> <tr> <td>01FFh</td> <td>511 Bytes</td> </tr> <tr> <td>...</td> <td>...</td> </tr> <tr> <td>0004h</td> <td>4 Bytes</td> </tr> <tr> <td>0003h</td> <td>3 Bytes</td> </tr> <tr> <td>0002h</td> <td>2 Bytes</td> </tr> <tr> <td>0001h</td> <td>1 Byte</td> </tr> <tr> <td>0000h</td> <td>No data transfer</td> </tr> </table>	0800h	2048 Bytes	0200h	512 Bytes	01FFh	511 Bytes	0004h	4 Bytes	0003h	3 Bytes	0002h	2 Bytes	0001h	1 Byte	0000h	No data transfer
0800h	2048 Bytes																					
...	...																					
0200h	512 Bytes																					
01FFh	511 Bytes																					
...	...																					
0004h	4 Bytes																					
0003h	3 Bytes																					
0002h	2 Bytes																					
0001h	1 Byte																					
0000h	No data transfer																					

Table 2-4 : Block Size Register

2.2.3 Block Count Register (Offset 006h)

This register is used to configure the number of data blocks.



Figure 2-3 : Block Count Register

Location	Attrib	Register Field Explanation										
15-00	RW	<p>Blocks Count For Current Transfer</p> <p>This register is enabled when Block Count Enable in the <i>Transfer Mode</i> register is set to 1 and is valid only for multiple block transfers. The Host Driver shall set this register to a value between 1 and the maximum block count. The Host Controller decrements the block count after each block transfer and stops when the count reaches zero. Setting the block count to 0 results in no data blocks is transferred.</p> <p>This register should be accessed only when no transaction is executing (i.e., after transactions are stopped). During data transfer, read operations on this register may return an invalid value and write operations are ignored.</p> <p>When a suspend command is completed, the number of blocks yet to be transferred can be determined by reading this register. Before issuing a resume command, the Host Driver shall restore the previously saved block count.</p> <table border="1" style="margin-left: 20px;"> <tr> <td>FFFFh</td> <td>65535 blocks</td> </tr> <tr> <td>...</td> <td>...</td> </tr> <tr> <td>0002h</td> <td>2 blocks</td> </tr> <tr> <td>0001h</td> <td>1 block</td> </tr> <tr> <td>0000h</td> <td>Stop Count</td> </tr> </table>	FFFFh	65535 blocks	0002h	2 blocks	0001h	1 block	0000h	Stop Count
FFFFh	65535 blocks											
...	...											
0002h	2 blocks											
0001h	1 block											
0000h	Stop Count											

Table 2-5 : Block Count Register

2.2.4 Argument 1 Register (Offset 008h)

This register contains the SD Command Argument.

**Figure 2-4 : Argument 1 Register**

Location	Attrib	Register Field Explanation
31-00	RW	Command Argument 1 The SD command argument is specified as bit39-8 of Command-Format in the Physical Layer Specification.

Table 2-6 : Argument 1 Register

2.2.5 Transfer Mode Register (Offset 00Ch)

This register is used to control the operation of data transfers. The Host Driver shall set this register before issuing a command which transfers data (Refer to **Data Present Select** in the *Command* register), or before issuing a Resume command. The Host Driver shall save the value of this register when the data transfer is suspended (as a result of a Suspend command) and restore it before issuing a Resume command. To prevent data loss, the Host Controller shall implement write protection for this register during data transactions. Writes to this register shall be ignored when the Command Inhibit (DAT) in the *Present State* register is 1.

D15	D06	D05	D04	D03 - D02	D01	D00
Rsvd		Multi / Single Block Select	Data Transfer Direction Select	Auto Command Enable	Block Count Enable	DMA Enable

Figure 2-5 : Transfer Mode Register

Location	Attrib	Register Field Explanation				
15-06	Rsvd	Reserved				
05	RW	<p>Multi / Single Block Select This bit is set when issuing multiple-block transfer commands using DAT line. For any other commands, this bit shall be set to 0. If this bit is 0, it is not necessary to set the <i>Block Count</i> register. (Refer to Table 2-8)</p> <table border="1"> <tr> <td>1</td> <td>Multiple Block</td> </tr> <tr> <td>0</td> <td>Single Block</td> </tr> </table>	1	Multiple Block	0	Single Block
1	Multiple Block					
0	Single Block					
04	RW	<p>Data Transfer Direction Select This bit defines the direction of DAT line data transfers. The bit is set to 1 by the Host Driver to transfer data from the SD card to the SD Host Controller and it is set to 0 for all other commands.</p> <table border="1"> <tr> <td>1</td> <td>Read (Card to Host)</td> </tr> <tr> <td>0</td> <td>Write (Host to Card)</td> </tr> </table>	1	Read (Card to Host)	0	Write (Host to Card)
1	Read (Card to Host)					
0	Write (Host to Card)					

03-02	Rsvd	<p>Auto CMD Enable This field determines use of auto command functions.</p> <table border="1" data-bbox="467 283 993 415"> <tr> <td>00b</td> <td>Auto Command Disabled</td> </tr> <tr> <td>01b</td> <td>Auto CMD12 Enable</td> </tr> <tr> <td>10b</td> <td>Auto CMD23 Enable</td> </tr> <tr> <td>11b</td> <td>Reserved</td> </tr> </table> <p>There are two methods to stop Multiple-block read and write operation.</p> <p>(1) Auto CMD12 Enable When this field is set to 01b, the Host Controller issues CMD12 automatically when last block transfer is completed. Auto CMD12 error is indicated to the <i>Auto CMD Error Status</i> register. The Host Driver shall not set this bit if the command does not require CMD12. In particular, secure commands defined in the Part 3 File Security specification do not require CMD12.</p> <p>(2) Auto CMD23 Enable When this bit field is set to 10b, the Host Controller issues a CMD23 automatically before issuing a command specified in the Command Register. The Host Controller Version 3.00 and later shall support this function. The following conditions are required to use the Auto CMD23.</p> <ul style="list-style-type: none"> • Auto CMD23 Supported (Host Controller Version is 3.00 or later) • A memory card that supports CMD23 (SCR[33]=1) • If DMA is used, it shall be ADMA. • Only when CMD18 or CMD25 is issued (Note, the Host Controller does not check command index.) <p>Auto CMD23 can be used with or without ADMA. By writing the <i>Command</i> register, the Host Controller issues a CMD23 first and then issues a command specified by the Command Index in <i>Command</i> register. If response errors of CMD23 are detected, the second command is not issued. A CMD23 error is indicated in the <i>Auto CMD Error Status</i> register. 32-bit block count value for CMD23 is set to <i>SDMA System Address / Argument 2</i> register.</p>	00b	Auto Command Disabled	01b	Auto CMD12 Enable	10b	Auto CMD23 Enable	11b	Reserved
00b	Auto Command Disabled									
01b	Auto CMD12 Enable									
10b	Auto CMD23 Enable									
11b	Reserved									
01	RW	<p>Block Count Enable This bit is used to enable the <i>Block Count</i> register, which is only relevant for multiple block transfers. When this bit is 0, the <i>Block Count</i> register is disabled, which is useful in executing an infinite transfer. (Refer to Table 2-8) If ADMA2 data transfer is more than 65535 blocks, this bit shall be set to 0. In this case, data transfer length is designated by Descriptor Table.</p> <table border="1" data-bbox="467 1579 805 1638"> <tr> <td>1</td> <td>Enable</td> </tr> <tr> <td>0</td> <td>Disable</td> </tr> </table>	1	Enable	0	Disable				
1	Enable									
0	Disable									

00	RW	<p>DMA Enable</p> <p>This bit enables DMA functionality as described in section 1.4. DMA can be enabled only if it is supported as indicated in the <i>Capabilities</i> register. One of the DMA modes can be selected by DMA Select in the <i>Host Control 1</i> register. If DMA is not supported, this bit is meaningless and shall always read 0. If this bit is set to 1, a DMA operation shall begin when the Host Driver writes to the upper byte of <i>Command</i> register (00Fh).</p> <table border="1"> <tr> <td>1</td> <td>DMA Data transfer</td> </tr> <tr> <td>0</td> <td>No data transfer or Non DMA data transfer</td> </tr> </table>	1	DMA Data transfer	0	No data transfer or Non DMA data transfer
1	DMA Data transfer					
0	No data transfer or Non DMA data transfer					

Table 2-7 : Transfer Mode Register

Table 2-8 shows the summary of how register settings determine types of data transfer.

Multi/Single Block Select	Block Count Enable	Block Count	Function
0	Don't care	Don't care	Single Transfer
1	0	Don't care	Infinite Transfer
1	1	Not Zero	Multiple Transfer
1	1	Zero	Stop Multiple Transfer

Table 2-8 : Determination of Transfer Type

SD Host Controller Simplified Specification Version 3.00**2.2.6 Command Register (Offset 00Eh)**

The Host Driver shall check the **Command Inhibit (DAT)** bit and **Command Inhibit (CMD)** bit in the *Present State* register before writing to this register. Writing to the upper byte of this register triggers SD command generation. The Host Driver has the responsibility to write this register because the Host Controller does not protect for writing when **Command Inhibit (CMD)** is set.

D15	D14	D13	D08	D07	D06	D05	D04	D03	D02	D01	D00	
Rsvd		Command Index				Command Type	Data Present Select	Command Index Check Enable	Command CRC Check Enable	Rsvd	Response Type Select	

Figure 2-6 : Command Register

Location	Attrib	Register Field Explanation												
15-14	Rsvd	Reserved												
13-08	RW	<p>Command Index These bits shall be set to the command number (CMD0-63, ACMD0-63) that is specified in bits 45-40 of the Command-Format in the Physical Layer Specification and SDIO Card Specification.</p>												
07-06	RW	<p>Command Type There are three types of special commands: Suspend, Resume and Abort. These bits shall be set to 00b for all other commands.</p> <p>(1) Suspend Command If the Suspend command succeeds, the Host Controller shall assume the SD Bus has been released and that it is possible to issue the next command, which uses the DAT line. The Host Controller shall de-assert Read Wait for read transactions and stop checking busy for write transactions. The interrupt cycle shall start, in 4-bit mode. If the Suspend command fails, the Host Controller shall maintain its current state, and the Host Driver shall restart the transfer by setting Continue Request in the <i>Block Gap Control</i> register. (Refer to 3.12.1 Suspend Sequence)</p> <p>(2) Resume Command The Host Driver re-starts the data transfer by restoring the registers in the range of 000-00Dh. (Refer to Figure 1-4 in section 1.6 for the register map.) The Host Controller shall check for busy before starting write transfers.</p> <p>(3) Abort Command If this command is set when executing a read transfer, the Host Controller shall stop reads to the buffer. If this command is set when executing a write transfer, the Host Controller shall stop driving the DAT line. After issuing the Abort command, the Host Driver should issue a software reset. (Refer to 3.8 Abort Transaction)</p> <table border="1"> <tr> <td>11b</td> <td>Abort</td> <td>CMD12, CMD52 for writing "I/O Abort" in CCCR</td> </tr> <tr> <td>10b</td> <td>Resume</td> <td>CMD52 for writing "Function Select" in CCCR</td> </tr> <tr> <td>01b</td> <td>Suspend</td> <td>CMD52 for writing "Bus Suspend" in CCCR</td> </tr> <tr> <td>00b</td> <td>Normal</td> <td>Other commands</td> </tr> </table>	11b	Abort	CMD12, CMD52 for writing "I/O Abort" in CCCR	10b	Resume	CMD52 for writing "Function Select" in CCCR	01b	Suspend	CMD52 for writing "Bus Suspend" in CCCR	00b	Normal	Other commands
11b	Abort	CMD12, CMD52 for writing "I/O Abort" in CCCR												
10b	Resume	CMD52 for writing "Function Select" in CCCR												
01b	Suspend	CMD52 for writing "Bus Suspend" in CCCR												
00b	Normal	Other commands												

SD Host Controller Simplified Specification Version 3.00

05	RW	<p>Data Present Select This bit is set to 1 to indicate that data is present and shall be transferred using the DAT line. It is set to 0 for the following:</p> <p>(1) Commands using only CMD line (ex. CMD52). (2) Commands with no data transfer but using busy signal on DAT[0] line (R1b or R5b ex. CMD38) (3) Resume command</p> <table border="1"> <tr> <td>1</td> <td>Data Present</td> </tr> <tr> <td>0</td> <td>No Data Present</td> </tr> </table>	1	Data Present	0	No Data Present				
1	Data Present									
0	No Data Present									
04	RW	<p>Command Index Check Enable If this bit is set to 1, the Host Controller shall check the Index field in the response to see if it has the same value as the command index. If it is not, it is reported as a Command Index Error. If this bit is set to 0, the Index field is not checked.</p> <table border="1"> <tr> <td>1</td> <td>Enable</td> </tr> <tr> <td>0</td> <td>Disable</td> </tr> </table>	1	Enable	0	Disable				
1	Enable									
0	Disable									
03	RW	<p>Command CRC Check Enable If this bit is set to 1, the Host Controller shall check the CRC field in the response. If an error is detected, it is reported as a Command CRC Error. If this bit is set to 0, the CRC field is not checked. The position of CRC field is determined according to the length of the response. (Refer to definition in D01-00 and Table 2-10 below.)</p> <table border="1"> <tr> <td>1</td> <td>Enable</td> </tr> <tr> <td>0</td> <td>Disable</td> </tr> </table>	1	Enable	0	Disable				
1	Enable									
0	Disable									
02	Rsvd	Reserved								
01-00	RW	<p>Response Type Select</p> <table border="1"> <tr> <td>00</td> <td>No Response</td> </tr> <tr> <td>01</td> <td>Response Length 136</td> </tr> <tr> <td>10</td> <td>Response Length 48</td> </tr> <tr> <td>11</td> <td>Response Length 48 check Busy after response</td> </tr> </table>	00	No Response	01	Response Length 136	10	Response Length 48	11	Response Length 48 check Busy after response
00	No Response									
01	Response Length 136									
10	Response Length 48									
11	Response Length 48 check Busy after response									

Table 2-9 : Command Register

Response Type	Index Check Enable	CRC Check Enable	Name of Response Type
00	0	0	No Response
01	0	1	R2
10	0	0	R3, R4
10	1	1	R1, R5, R6, R7
11	1	1	R1b, R5b

Table 2-10 : Relation between Parameters and the Name of Response Type

These bits determine Response types.

Note: In the SDIO specification, response type notation of R5b is not defined. R5 includes R5b in the SDIO specification. But R5b is defined in this specification to specify the Host Controller shall check busy after receiving response. For example, usually CMD52 is used as R5 but I/O abort command shall be used as R5b.

Implementation Note: the CRC field for R3 and R4 is expected to be all "1" bits. The CRC check should be disabled for these response types.

2.2.7 Response Register (Offset 010h)

This register is used to store responses from SD cards.

Offset 010h	D31	D00
	Command Response 0 – 31	
Offset 014h	D31	D00
	Command Response 32 – 63	
Offset 018h	D31	D00
	Command Response 64 – 95	
Offset 01Ch	D31	D00
	Command Response 96 – 127	

Figure 2-7 : Response Register

Location	Attrib	Register Field Explanation
127-00	ROC	<p>Command Response</p> <p>The Table 2-12 describes the mapping of command responses from the SD Bus to this register for each response type. In the table, R[] refers to a bit range within the response data as transmitted on the SD Bus, REP[] refers to a bit range within the <i>Response</i> register.</p>

Table 2-11 : Response Register

Kind of Response	Meaning of Response	Response Field	Response Register
R1, R1b (normal response)	Card Status	R [39:8]	REP [31:0]
R1b (Auto CMD12 response)	Card Status for Auto CMD12	R [39:8]	REP [127:96]
R1 (Auto CMD23 response)	Card Status for Auto CMD23	R [39:8]	REP [127:96]
R2 (CID, CSD register)	CID or CSD reg. incl.	R [127:8]	REP [119:0]
R3 (OCR register)	OCR register for memory	R [39:8]	REP [31:0]
R4 (OCR register)	OCR register for I/O etc	R [39:8]	REP [31:0]
R5,R5b	SDIO response	R [39:8]	REP [31:0]
R6 (Published RCA response)	New published RCA[31:16] etc	R [39:8]	REP [31:0]

Table 2-12 : Response Bit Definition for Each Response Type.

The Response Field indicates bit positions of "Responses" defined in the Physical Layer Specification.

The Table 2-12 shows that most responses with a length of 48 (R[47:0]) have 32 bits of the response data (R[39:8]) stored in the *Response* register at REP[31:0]. Responses of type R1b (Auto CMD12 responses) and R1 (Auto CMD23 response) have response data bits R[39:8] stored in the *Response* register at REP[127:96]. Responses with length 136 (R[135:0]) have 120 bits of the response data (R[127:8]) stored in the *Response* register at REP[119:0].

To be able to read the response status efficiently, the Host Controller only stores part of the response data in the *Response* register. This enables the Host Driver to read 32 bits of response data efficiently in one read cycle on a 32-bit bus system. Parts of the response, the Index field and the CRC, are checked by the Host Controller (as specified by the **Command Index Check Enable** and the **Command CRC Check Enable** bits in the *Command* register) and generate an error interrupt if an error is detected. The bit range for the CRC check depends on the response length. If the response length is 48, the Host Controller shall check R[47:1], and if the response length is 136 the Host Controller shall check R[119:1].

Since the Host Controller may have a multiple block data DAT line transfer executing concurrently with a CMD_wo_DAT command, the Host Controller stores the Auto CMD12 response in the upper bits (REP[127:96]) of the *Response* register. The CMD_wo_DAT response is stored in REP[31:0]. This allows the Host Controller to avoid overwriting the Auto CMD12 response with the CMD_wo_DAT and vice versa.

While executing Auto CMD23, the response of CMD23 is saved to REP [127:96] and the response of multiple-block read and write command is save to REP [31:0]. The response error of CMD23 is indicated in the *Auto CMD Error Status* register.

When the Host Controller modifies part of the *Response* register, as shown in the Table 2-12, it shall preserve the unmodified bits.

2.2.8 Buffer Data Port Register (Offset 020h)

32-bit data port register to access internal buffer.



Figure 2-8 : Buffer Data Port Register

Buffer can be accessed through 32-bit *Data Port* register.

Location	Attrib	Register Field Explanation
31-00	RW	Buffer Data The Host Controller buffer can be accessed through this 32-bit <i>Data Port</i> register. Refer to Section 1.7

Table 2-13 : Buffer Data Port Register

SD Host Controller Simplified Specification Version 3.00**2.2.9 Present State Register (Offset 024h)**

The Host Driver can get status of the Host Controller from this 32-bit read only register.

D31				D25		D24	D23		D20		D19	D18	D17	D16
Rsvd						CMD Line Signal Level	DAT[3:0] Line Signal Level				Write Protect Switch Pin Level	Card Detect Pin Level	Card State Stable	Card Inserted
D15			D12	D11	D10	D09	D08	D07		D04	D03	D02	D01	D00
Rsvd			Buffer Read Enable	Buffer Write Enable	Read Transfer Active	Write Transfer Active	Rsvd				Re-Tuning Request	DAT Line Active	Command Inhibit (DAT)	Command Inhibit (CMD)

Figure 2-9 : Present State Register

Location	Attrib	Register Field Explanation								
31-25	Rsvd	Reserved								
24	RO	CMD Line Signal Level This status is used to check the CMD line level to recover from errors, and for debugging.								
23-20	RO	DAT[3:0] Line Signal Level This status is used to check the DAT line level to recover from errors, and for debugging. This is especially useful in detecting the busy signal level from DAT[0] . <table border="1" style="margin-left: 20px;"> <tr> <td>D23</td> <td>DAT[3]</td> </tr> <tr> <td>D22</td> <td>DAT[2]</td> </tr> <tr> <td>D21</td> <td>DAT[1]</td> </tr> <tr> <td>D20</td> <td>DAT[0]</td> </tr> </table>	D23	DAT[3]	D22	DAT[2]	D21	DAT[1]	D20	DAT[0]
D23	DAT[3]									
D22	DAT[2]									
D21	DAT[1]									
D20	DAT[0]									
19	RO	Write Protect Switch Pin Level The Write Protect Switch is supported for memory and combo cards. This bit reflects the SDWP# pin. <table border="1" style="margin-left: 20px;"> <tr> <td>1</td> <td>Write enabled (SDWP#=1)</td> </tr> <tr> <td>0</td> <td>Write protected (SDWP#=0)</td> </tr> </table>	1	Write enabled (SDWP#=1)	0	Write protected (SDWP#=0)				
1	Write enabled (SDWP#=1)									
0	Write protected (SDWP#=0)									
18	RO	Card Detect Pin Level This bit reflects the inverse value of the SDCD# pin. Debouncing is not performed on this bit. This bit may be valid when Card State Stable is set to 1, but it is not guaranteed because of propagation delay. Use of this bit is limited to testing since it must be debounced by software. <table border="1" style="margin-left: 20px;"> <tr> <td>1</td> <td>Card present (SDCD#=0)</td> </tr> <tr> <td>0</td> <td>No card present (SDCD#=1)</td> </tr> </table>	1	Card present (SDCD#=0)	0	No card present (SDCD#=1)				
1	Card present (SDCD#=0)									
0	No card present (SDCD#=1)									

SD Host Controller Simplified Specification Version 3.00

17	RO	<p>Card State Stable</p> <p>This bit is used for testing. If it is 0, the Card Detect Pin Level is not stable. If this bit is set to 1, it means the Card Detect Pin Level is stable. No Card state can be detected by this bit is set to 1 and Card Inserted is set to 0. The Software Reset For All in the <i>Software Reset</i> register shall not affect this bit.</p> <table border="1" data-bbox="524 415 966 478"> <tr> <td>1</td> <td>No Card or Inserted</td> </tr> <tr> <td>0</td> <td>Reset or Debouncing</td> </tr> </table>	1	No Card or Inserted	0	Reset or Debouncing
1	No Card or Inserted					
0	Reset or Debouncing					
16	RO	<p>Card Inserted</p> <p>This bit indicates whether a card has been inserted. The Host Controller shall debounce this signal so that the Host Driver will not need to wait for it to stabilize. Changing from 0 to 1 generates a Card Insertion interrupt in the <i>Normal Interrupt Status</i> register and changing from 1 to 0 generates a Card Removal interrupt in the <i>Normal Interrupt Status</i> register. The Software Reset For All in the <i>Software Reset</i> register shall not affect this bit.</p> <p>If a card is removed while its power is on and its clock is oscillating, the Host Controller shall clear SD Bus Power in the <i>Power Control</i> register (Refer to Section 2.2.11) and SD Clock Enable in the <i>Clock Control</i> register (Refer to Section 2.2.14).</p> <p>When this bit is changed from 1 to 0, the Host Controller shall immediately stop driving CMD and DAT[3:0] (tri-state).</p> <p>In addition, the Host Driver should clear the Host Controller by the Software Reset For All in <i>Software Reset</i> register. The card detect is active regardless of the SD Bus Power.</p> <table border="1" data-bbox="524 1056 1128 1119"> <tr> <td>1</td> <td>Card Inserted</td> </tr> <tr> <td>0</td> <td>Reset or Debouncing or No Card</td> </tr> </table>	1	Card Inserted	0	Reset or Debouncing or No Card
1	Card Inserted					
0	Reset or Debouncing or No Card					

Table 2-14 : Present State Register (Part 1)

Figure 2-10 shows the state definitions of hardware that handles "Debouncing".

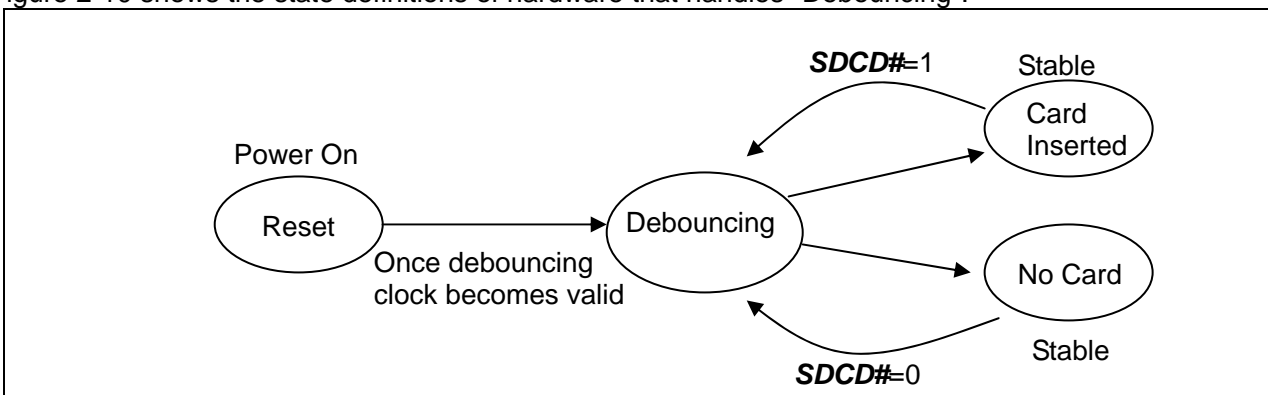
**Figure 2-10 : Card Detect State**

Implementation Note: The Host Controller starts in "Reset" state at power on and changes to the "Debouncing" state once the debouncing clock is valid. In the "Debouncing" state, if the Host Controller detects that the signal (**SDCD#**) is stable during the debounce period, the state shall change to "Card Inserted" or "No Card". If the card is removed while in the "Card Inserted" state, it will immediately change to the "Debouncing" state. Since the card detect signal is then not stable, the Host Controller will change to the "Debouncing" state.

Location	Attrib					
15-12	Rsvd	Reserved				
11	ROC	<p>Buffer Read Enable</p> <p>This status is used for non-DMA read transfers. The Host Controller may implement multiple buffers to transfer data efficiently. This read only flag indicates that valid data exists in the host side buffer. If this bit is 1, readable data exists in the buffer. A change of this bit from 1 to 0 occurs when all the block data is read from the buffer. A change of this bit from 0 to 1 occurs when block data is ready in the buffer and generates the Buffer Read Ready interrupt.</p> <table border="1"> <tr> <td>1</td> <td>Read enable</td> </tr> <tr> <td>0</td> <td>Read disable</td> </tr> </table>	1	Read enable	0	Read disable
1	Read enable					
0	Read disable					
10	ROC	<p>Buffer Write Enable</p> <p>This status is used for non-DMA write transfers. The Host Controller can implement multiple buffers to transfer data efficiently. This read only flag indicates if space is available for write data. If this bit is 1, data can be written to the buffer. A change of this bit from 1 to 0 occurs when all the block data is written to the buffer. A change of this bit from 0 to 1 occurs when top of block data can be written to the buffer and generates the Buffer Write Ready interrupt. The Host Controller should neither set Buffer Write Enable nor generate Buffer Write Ready Interrupt after the last block data is written to the Buffer Data Port Register.</p> <table border="1"> <tr> <td>1</td> <td>Write enable</td> </tr> <tr> <td>0</td> <td>Write disable</td> </tr> </table>	1	Write enable	0	Write disable
1	Write enable					
0	Write disable					
09	ROC	<p>Read Transfer Active</p> <p>This status is used for detecting completion of a read transfer. Refer to Section 3.12.3 for sequence details.</p> <p>This bit is set to 1 for either of the following conditions:</p> <ol style="list-style-type: none"> (1) After the end bit of the read command. (2) When read operation is restarted by writing a 1 to Continue Request in the <i>Block Gap Control</i> register. <p>This bit is cleared to 0 for either of the following conditions::</p> <ol style="list-style-type: none"> (1) When the last data block as specified by block length is transferred to the System. (2) In case of ADMA2, end of read operation is designated by Descriptor Table. (3) When all valid data blocks in the Host Controller have been transferred to the System and no current block transfers are being sent as a result of the Stop At Block Gap Request being set to 1. <p>A Transfer Complete interrupt is generated when this bit changes to 0.</p> <table border="1"> <tr> <td>1</td> <td>Transferring data</td> </tr> <tr> <td>0</td> <td>No valid data</td> </tr> </table>	1	Transferring data	0	No valid data
1	Transferring data					
0	No valid data					

SD Host Controller Simplified Specification Version 3.00

08	ROC	<p>Write Transfer Active</p> <p>This status indicates a write transfer is active. If this bit is 0, it means no valid write data exists in the Host Controller. Refer to Section 3.12.4 for more details on the sequence of events.</p> <p>This bit is set in either of the following cases:</p> <ol style="list-style-type: none"> (1) After the end bit of the write command. (2) When write operation is restarted by writing a 1 to Continue Request in the <i>Block Gap Control</i> register. <p>This bit is cleared in either of the following cases:</p> <ol style="list-style-type: none"> (1) After getting the CRC status of the last data block as specified by the transfer count (Single and Multiple) In case of ADMA2, transfer count is designated by Descriptor Table. (2) After getting the CRC status of any block where data transmission is about to be stopped by a Stop At Block Gap Request. <p>During a write transaction, a Block Gap Event interrupt is generated when this bit is changed to 0, as the result of the Stop At Block Gap Request being set. This status is useful for the Host Driver in determining non DAT line commands can be issued during write busy.</p> <table border="1" data-bbox="446 856 833 926"> <tr> <td>1</td> <td>Transferring data</td> </tr> <tr> <td>0</td> <td>No valid data</td> </tr> </table>	1	Transferring data	0	No valid data
1	Transferring data					
0	No valid data					
07-04	Rsvd	Reserved				
03	ROC	<p>Re-Tuning Request</p> <p>Host Controller may request Host Driver to execute re-tuning sequence by setting this bit when the data window is shifted by temperature drift and a tuned sampling point does not have a good margin to receive correct data.</p> <p>This bit is cleared when a command is issued with setting Execute Tuning in the <i>Host Control 2</i> register.</p> <p>Changing of this bit from 0 to 1 generates Re-Tuning Event. Refer to <i>Normal Interrupt Status</i> registers for more detail.</p> <p>This bit isn't set to 1 if Sampling Clock Select in the <i>Host Control 2</i> register is set to 0 (using fixed sampling clock). Refer to Re-Tuning Modes in the Capabilities register for more detail.</p> <table border="1" data-bbox="446 1346 1089 1409"> <tr> <td>1</td> <td>Sampling clock needs re-tuning</td> </tr> <tr> <td>0</td> <td>Fixed or well tuned sampling clock</td> </tr> </table>	1	Sampling clock needs re-tuning	0	Fixed or well tuned sampling clock
1	Sampling clock needs re-tuning					
0	Fixed or well tuned sampling clock					
02	ROC	<p>DAT Line Active</p> <p>This bit indicates whether one of the DAT line on SD Bus is in use.</p> <p>(a) In the case of read transactions</p> <p>This status indicates whether a read transfer is executing on the SD Bus. Changing this value from 1 to 0 generates a Block Gap Event interrupt in the <i>Normal Interrupt Status</i> register, as the result of the Stop At Block Gap Request being set. Refer to Section 3.12.3 for details on timing.</p> <p>This bit shall be set in either of the following cases:</p> <ol style="list-style-type: none"> (1) After the end bit of the read command. (2) When writing a 1 to Continue Request in the <i>Block Gap Control</i> register to restart a read transfer. <p>This bit shall be cleared in either of the following cases:</p>				

SD Host Controller Simplified Specification Version 3.00

		<p>(1) When the end bit of the last data block is sent from the SD Bus to the Host Controller. In case of ADMA2, the last block is designated by the last transfer of Descriptor Table.</p> <p>(2) When a read transfer is stopped at the block gap initiated by a Stop At Block Gap Request.</p> <p>The Host Controller shall stop read operation at the start of the interrupt cycle of the next block gap by driving Read Wait or stopping SD clock. If the Read Wait signal is already driven (due to data buffer cannot receive data), the Host Controller can continue to stop read operation by driving the Read Wait signal. It is necessary to support Read Wait in order to use suspend / resume function.</p> <p>(b) In the case of write transactions This status indicates that a write transfer is executing on the SD Bus. Changing this value from 1 to 0 generate a Transfer Complete interrupt in the <i>Normal Interrupt Status</i> register. Refer to Section 3.12.4 for sequence details.</p> <p>This bit shall be set in either of the following cases:</p> <p>(1) After the end bit of the write command.</p> <p>(2) When writing to 1 to Continue Request in the <i>Block Gap Control</i> register to continue a write transfer.</p> <p>This bit shall be cleared in either of the following cases:</p> <p>(1) When the SD card releases write busy of the last data block. If SD card does not drive busy signal for 8 SD Clocks, the Host Controller shall consider the card drive "Not Busy". In case of ADMA2, the last block is designated by the last transfer of Descriptor Table.</p> <p>(2) When the SD card releases write busy prior to waiting for write transfer as a result of a Stop At Block Gap Request.</p> <p>(c) Command with busy This status indicates whether a command indicates busy (ex. erase command for memory) is executing on the SD Bus. This bit is set after the end bit of the command with busy and cleared when busy is de-asserted. Changing this bit from 1 to 0 generate a Transfer Complete interrupt in the <i>Normal Interrupt Status</i> register. Refer Figure 2-11 to Figure 2-13.</p> <table border="1" data-bbox="444 1339 1047 1402"> <tr> <td>1</td> <td>DAT Line Active</td> </tr> <tr> <td>0</td> <td>DAT Line Inactive</td> </tr> </table>	1	DAT Line Active	0	DAT Line Inactive
1	DAT Line Active					
0	DAT Line Inactive					
01	ROC	<p>Command Inhibit (DAT) This status bit is generated if either the DAT Line Active or the Read Transfer Active is set to 1. If this bit is 0, it indicates the Host Controller can issue the next SD Command. Commands with busy signal belong to Command Inhibit (DAT) (ex. R1b, R5b type). Changing from 1 to 0 generates a Transfer Complete interrupt in the <i>Normal Interrupt Status</i> register.</p> <p>Note: The SD Host Driver can save registers in the range of 000-00Dh for a suspend transaction after this bit has changed from 1 to 0.</p> <table border="1" data-bbox="444 1696 1239 1757"> <tr> <td>1</td> <td>Cannot issue command which uses the DAT line</td> </tr> <tr> <td>0</td> <td>Can issue command which uses the DAT line</td> </tr> </table>	1	Cannot issue command which uses the DAT line	0	Can issue command which uses the DAT line
1	Cannot issue command which uses the DAT line					
0	Can issue command which uses the DAT line					

00	ROC	<p>Command Inhibit (CMD)</p> <p>If this bit is 0, it indicates the CMD line is not in use and the Host Controller can issue a SD Command using the CMD line.</p> <p>This bit is set immediately after the <i>Command</i> register (00Fh) is written. This bit is cleared when the command response is received. Auto CMD12 and Auto CMD23 consist of two responses. In this case, this bit is not cleared by the response of CMD12 or CMD23 but cleared by the response of a read/write command.</p> <p>Status issuing Auto CMD12 is not read from this bit. So if a command is issued during Auto CMD12 operation, Host Controller shall manage to issue two commands: CMD12 and a command set by <i>Command</i> register.</p> <p>Even if the Command Inhibit (DAT) is set to 1, commands using only the CMD line can be issued if this bit is 0. Changing from 1 to 0 generates a Command Complete Interrupt in the <i>Normal Interrupt Status</i> register.</p> <p>If the Host Controller cannot issue the command because of a command conflict error (Refer to Command CRC Error in Section 2.2.18) or because of Command Not Issued By Auto CMD12 Error (Refer to Section 2.2.23), this bit shall remain 1 and the Command Complete is not set.</p> <table border="1" data-bbox="444 800 1143 861"> <tr> <td data-bbox="444 800 594 831">1</td> <td data-bbox="594 800 1143 831">Cannot issue command</td> </tr> <tr> <td data-bbox="444 831 594 861">0</td> <td data-bbox="594 831 1143 861">Can issue command using only CMD line</td> </tr> </table>	1	Cannot issue command	0	Can issue command using only CMD line
1	Cannot issue command					
0	Can issue command using only CMD line					

Table 2-15 : Present State Register (Part 2)

Implementation Note:

The Host Driver can issue CMD0, CMD12, CMD13 (for memory) and CMD52 (for SDIO) when the **DAT** lines are busy during data transfer. These commands can be issued when **Command Inhibit (CMD)** is set to zero. Other commands shall be issued when **Command Inhibit (DAT)** is set to zero. Possible changes to the Physical Layer Specification may add other commands to this list in the future.

Implementation Note:

Some fields defined in the Present State Register change values asynchronous to the system clock. The System reads these statuses through the System Bus Interface and it may require data stable period during bus cycle. The Host Controller should sample and hold values during reads from this register according to the timing required by the System Bus Interface specification.

Figure 2-11 to Figure 2-13 shows the timing of setting and clearing the **Command Inhibit (DAT)** and the **Command Inhibit (CMD)**.

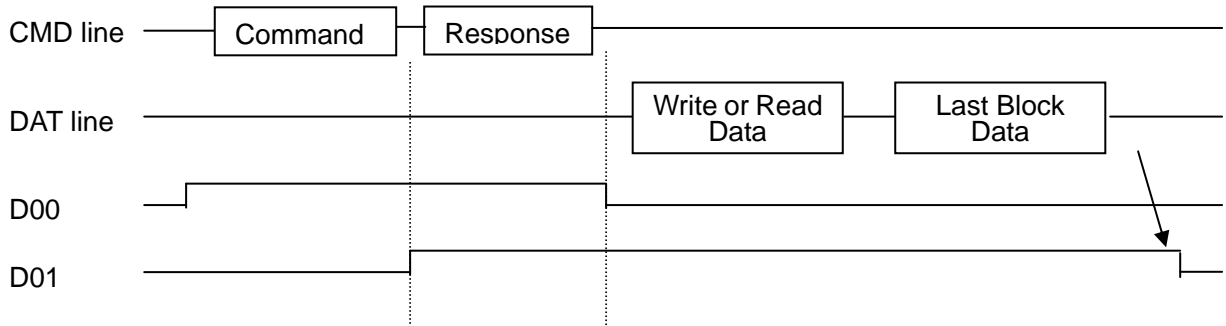

Figure 2-11 : Timing of Command Inhibit (DAT) and Command Inhibit (CMD) with Data Transfer

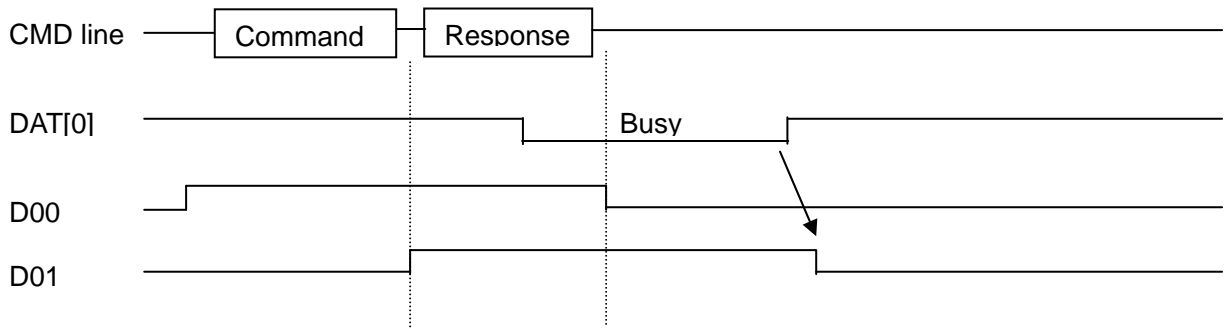

Figure 2-12 : Timing of Command Inhibit (DAT) for the Case of Response with Busy

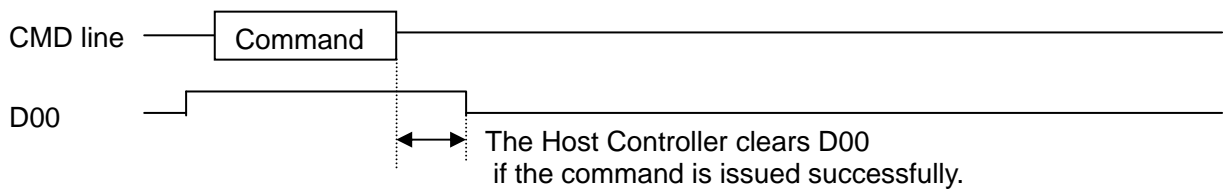

Figure 2-13 : Timing of Command Inhibit (CMD) for the Case of No Response Command

2.2.10 Host Control 1 Register (Offset 028h)

D07	D06	D05	D04	D03	D02	D01	D00
Card Detect Signal Selection	Card Detect Test Level	Extended Data Transfer Width	DMA Select		High Speed Enable	Data Transfer Width	LED Control

Figure 2-14 : Host Control 1 Register

Location	Attrib	Register Field Explanation								
07	RW	<p>Card Detect Signal Selection This bit selects source for the card detection.</p> <table border="1"> <tr> <td>1</td> <td>The Card Detect Test Level is selected (for test purpose)</td> </tr> <tr> <td>0</td> <td>SDCD# is selected (for normal use)</td> </tr> </table> <p>When the source for the card detection is switched, the interrupt should be disabled during the switching period by clearing the <i>Interrupt Status/Signal Enable</i> register in order to mask unexpected interrupt being caused by the glitch. The <i>Interrupt Status/Signal Enable</i> should be disabled during over the period of debouncing.</p>	1	The Card Detect Test Level is selected (for test purpose)	0	SDCD# is selected (for normal use)				
1	The Card Detect Test Level is selected (for test purpose)									
0	SDCD# is selected (for normal use)									
06	RW	<p>Card Detect Test Level This bit is enabled while the Card Detect Signal Selection is set to 1 and it indicates card inserted or not.</p> <table border="1"> <tr> <td>1</td> <td>Card Inserted</td> </tr> <tr> <td>0</td> <td>No Card</td> </tr> </table>	1	Card Inserted	0	No Card				
1	Card Inserted									
0	No Card									
05	RW	<p>Extended Data Transfer Width This bit controls 8-bit bus width mode for embedded device. Support of this function is indicated in 8-bit Support for Embedded Device in the <i>Capabilities</i> register. If a device supports 8-bit bus mode, this bit may be set to 1. If this bit is 0, bus width is controlled by Data Transfer Width in the <i>Host Control 1</i> register. This bit is not effective when multiple devices are installed on a bus slot (Slot Type is set to 10b in the <i>Capabilities</i> register). In this case, each device bus width is controlled by Bus Width Preset field in the <i>Shared Bus Control</i> register.</p> <table border="1"> <tr> <td>1</td> <td>8-bit Bus Width</td> </tr> <tr> <td>0</td> <td>Bus Width is Selected by Data Transfer Width</td> </tr> </table>	1	8-bit Bus Width	0	Bus Width is Selected by Data Transfer Width				
1	8-bit Bus Width									
0	Bus Width is Selected by Data Transfer Width									
04-03	RW	<p>DMA Select One of supported DMA modes can be selected. The host driver shall check support of DMA modes by referring the <i>Capabilities</i> register. Use of selected DMA is determined by DMA Enable of the <i>Transfer Mode</i> register.</p> <table border="1"> <tr> <td>00</td> <td>SDMA is selected</td> </tr> <tr> <td>01</td> <td>Reserved (New assignment is not allowed)</td> </tr> <tr> <td>10</td> <td>32-bit Address ADMA2 is selected</td> </tr> <tr> <td>11</td> <td>Reserved (will be modified by Version 4.00)</td> </tr> </table>	00	SDMA is selected	01	Reserved (New assignment is not allowed)	10	32-bit Address ADMA2 is selected	11	Reserved (will be modified by Version 4.00)
00	SDMA is selected									
01	Reserved (New assignment is not allowed)									
10	32-bit Address ADMA2 is selected									
11	Reserved (will be modified by Version 4.00)									

SD Host Controller Simplified Specification Version 3.00

02	RW	<p>High Speed Enable</p> <p>This bit is optional. Before setting this bit, the Host Driver shall check the High Speed Support in the <i>Capabilities</i> register. If this bit is set to 0 (default), the Host Controller outputs CMD line and DAT lines at the falling edge of the SD Clock (up to 25MHz). If this bit is set to 1, the Host Controller outputs CMD line and DAT lines at the rising edge of the SD Clock (up to 50MHz).</p> <p>If Preset Value Enable in the <i>Host Control 2</i> register is set to 1, Host Driver needs to reset SD Clock Enable before changing this field to avoid generating clock glitches. After setting this field, the Host Driver sets SD Clock Enable again.</p> <table border="1" data-bbox="443 541 901 604"> <tr> <td>1</td> <td>High Speed mode</td> </tr> <tr> <td>0</td> <td>Normal Speed mode</td> </tr> </table>	1	High Speed mode	0	Normal Speed mode
1	High Speed mode					
0	Normal Speed mode					
01	RW	<p>Data Transfer Width</p> <p>This bit selects the data width of the Host Controller. The Host Driver shall set it to match the data width of the SD card.</p> <table border="1" data-bbox="443 741 755 804"> <tr> <td>1</td> <td>4-bit mode</td> </tr> <tr> <td>0</td> <td>1-bit mode</td> </tr> </table>	1	4-bit mode	0	1-bit mode
1	4-bit mode					
0	1-bit mode					
00	RW	<p>LED Control</p> <p>This bit is used to caution the user not to remove the card while the SD card is being accessed. If the software is going to issue multiple SD commands, this bit can be set during all these transactions. It is not necessary to change for each transaction.</p> <table border="1" data-bbox="443 993 755 1056"> <tr> <td>1</td> <td>LED on</td> </tr> <tr> <td>0</td> <td>LED off</td> </tr> </table>	1	LED on	0	LED off
1	LED on					
0	LED off					

Table 2-16 : Host Control 1 Register

2.2.11 Power Control Register (Offset 029h)

D07	D04	D03	D01	D00
Rsvd		SD Bus Voltage Select		SD Bus Power

Figure 2-15 : Power Control Register

Location	Attrib	Register Field Explanation								
07-04	Rsvd	Reserved								
03-01	RW	<p>SD Bus Voltage Select By setting these bits, the Host Driver selects the voltage level for the SD card. Before setting this register, the Host Driver shall check the Voltage Support bits in the <i>Capabilities</i> register. If an unsupported voltage is selected, the Host System shall not supply SD Bus voltage.</p> <table border="1"> <tbody> <tr> <td>111b</td> <td>3.3V (Typ.)</td> </tr> <tr> <td>110b</td> <td>3.0V (Typ.)</td> </tr> <tr> <td>101b</td> <td>1.8V (Typ.)</td> </tr> <tr> <td>100b – 000b</td> <td>Reserved</td> </tr> </tbody> </table>	111b	3.3V (Typ.)	110b	3.0V (Typ.)	101b	1.8V (Typ.)	100b – 000b	Reserved
111b	3.3V (Typ.)									
110b	3.0V (Typ.)									
101b	1.8V (Typ.)									
100b – 000b	Reserved									
00	RW	<p>SD Bus Power Before setting this bit, the SD Host Driver shall set SD Bus Voltage Select. If the Host Controller detects the No Card state, this bit shall be cleared. If this bit is cleared, the Host Controller shall immediately stop driving CMD and DAT[3:0] (tri-state) and drive SDCLK to low level (Refer to Section 2.2.14).</p> <table border="1"> <tbody> <tr> <td>1</td> <td>Power on</td> </tr> <tr> <td>0</td> <td>Power off</td> </tr> </tbody> </table>	1	Power on	0	Power off				
1	Power on									
0	Power off									

Table 2-17 : Power Control Register

Implementation Note:

The Host Driver has responsibility to supply SD Bus voltage by **SD Bus Power**, according to SD card OCR and supply voltage capabilities depend on the Host System.

If the Host Driver selects an unsupported voltage in the **SD Bus Voltage Select** field, the Host Controller may ignore writes to SD Bus Power and keep its value at zero.

Implementation Note:

The Host System shall not supply SD Bus power when **SD Bus Power** is set to 0 and can supply SD Bus power when **SD Bus Power** is set to 1 depending on the system conditions (ex. Left of the battery).

2.2.12 Block Gap Control Register (Offset 02Ah)

D07	D04	D03	D02	D01	D00
Rsvd		Interrupt At Block Gap	Read Wait Control	Continue Request	Stop At Block Gap Request

Figure 2-16 : Block Gap Control Register

Location	Attrib	Register Field Explanation				
07-04	Rsvd	Reserved				
03	RW	<p>Interrupt At Block Gap This bit is valid only in 4-bit mode of the SDIO card and selects a sample point in the interrupt cycle. Setting to 1 enables interrupt detection at the block gap for a multiple block transfer. Setting to 0 disables interrupt detection during a multiple block transfer. If the SD card cannot signal an interrupt during a multiple block transfer, this bit should be set to 0. When the Host Driver detects an SD card insertion, it shall set this bit according to the CCCR of the SDIO card.</p> <table border="1"> <tr> <td>1</td> <td>Enabled</td> </tr> <tr> <td>0</td> <td>Disabled</td> </tr> </table>	1	Enabled	0	Disabled
1	Enabled					
0	Disabled					
02	RW	<p>Read Wait Control The read wait function is optional for SDIO cards. If the card supports read wait, set this bit to enable use of the read wait protocol to stop read data using the DAT[2] line. Otherwise, the Host Controller has to stop the SD Clock to hold read data, which restricts commands generation. When the Host Driver detects an SD card insertion, it shall set this bit according to the CCCR of the SDIO card. If the card does not support read wait, this bit shall never be set to 1 otherwise DAT line conflict may occur. If this bit is set to 0, Suspend/Resume cannot be supported.</p> <table border="1"> <tr> <td>1</td> <td>Enable Read Wait Control</td> </tr> <tr> <td>0</td> <td>Disable Read Wait Control</td> </tr> </table>	1	Enable Read Wait Control	0	Disable Read Wait Control
1	Enable Read Wait Control					
0	Disable Read Wait Control					
01	RWAC	<p>Continue Request This bit is used to restart a transaction, which was stopped using the Stop At Block Gap Request. To cancel stop at the block gap, set Stop At Block Gap Request to 0 and set this bit 1 to restart the transfer. The Host Controller automatically clears this bit in either of the following cases: (1) In the case of a read transaction, the DAT Line Active changes from 0 to 1 as a read transaction restarts. (2) In the case of a write transaction, the Write Transfer Active changes from 0 to 1 as the write transaction restarts. Therefore, it is not necessary for Host Driver to set this bit to 0. If Stop At Block Gap Request is set to 1, any write to this bit is ignored.</p> <table border="1"> <tr> <td>1</td> <td>Restart</td> </tr> <tr> <td>0</td> <td>Not affect</td> </tr> </table>	1	Restart	0	Not affect
1	Restart					
0	Not affect					
00	RW	<p>Stop At Block Gap Request This bit is used to stop executing read and write transaction at the next block gap for non-DMA, SDMA and ADMA transfers. The Host Driver shall leave this bit set</p>				

		<p>to 1 until the Transfer Complete is set to 1. Clearing both Stop At Block Gap Request and Continue Request shall not cause the transaction to restart. When Host Controller version is 1.00, the Host Driver can set this bit if the card supports Read Wait Control. When Host Controller version is 2.00 or later, the Host Driver can set this bit regardless of the card supports Read Wait Control. The Host Controller shall stop read transfer by using Read Wait or stopping SD clock. In case of write transfers in which the Host Driver writes data to the <i>Buffer Data Port</i> register, the Host Driver shall set this bit after all block data is written. If this bit is set to 1, the Host Driver shall not write data to <i>Buffer Data Port</i> register.</p> <p>This bit affects Read Transfer Active, Write Transfer Active, DAT Line Active and Command Inhibit (DAT) in the <i>Present State</i> register.</p> <p>Regarding detailed control of bits D01 and D00, refer to Section 3.8 and 3.12.</p> <table border="1" style="margin-left: auto; margin-right: auto;"> <tr> <td style="text-align: center;">1</td> <td style="text-align: center;">Stop</td> </tr> <tr> <td style="text-align: center;">0</td> <td style="text-align: center;">Transfer</td> </tr> </table>	1	Stop	0	Transfer
1	Stop					
0	Transfer					

Table 2-18 : Block Gap Control Register

There are three cases to restart the transfer after stop at the block gap. Which case is appropriate depends on whether the Host Controller issues a Suspend command or the SD card accepts the Suspend command.

- (1) If the Host Driver does not issue a Suspend command, the **Continue Request** shall be used to restart the transfer.
- (2) If the Host Driver issues a Suspend command and the SD card accepts it, a Resume command shall be used to restart the transfer.
- (3) If the Host Driver issues a Suspend command and the SD card does not accept it, the **Continue Request** shall be used to restart the transfer.

Any time **Stop At Block Gap Request** stops the data transfer, the Host Driver shall wait for **Transfer Complete** (in the *Normal Interrupt Status* register) before attempting to restart the transfer. When restarting the data transfer by **Continue Request**, the Host Driver shall clear **Stop At Block Gap Request** before or simultaneously.

2.2.13 Wakeup Control Register (Offset 02Bh)

This register is mandatory for the Host Controller, but wakeup functionality depends on the Host Controller system hardware and software. The Host Driver shall maintain voltage on the SD Bus, by setting **SD Bus Power** to 1 in the *Power Control* register, when wakeup event via Card Interrupt is desired.

D07	D03	D02	D01	D00
Rsvd		Wakeup Event Enable On SD Card Removal	Wakeup Event Enable On SD Card Insertion	Wakeup Event Enable On SD Card Interrupt

Figure 2-17 : Wakeup Control Register

Location	Attrib	Register Field Explanation				
07-03	Rsvd	Reserved				
02	RW	<p>Wakeup Event Enable On SD Card Removal This bit enables wakeup event via Card Removal assertion in the <i>Normal Interrupt Status</i> register. FN_WUS (Wake Up Support) in CIS does not affect this bit.</p> <table border="1"> <tr> <td>1</td> <td>Enable</td> </tr> <tr> <td>0</td> <td>Disable</td> </tr> </table>	1	Enable	0	Disable
1	Enable					
0	Disable					
01	RW	<p>Wakeup Event Enable On SD Card Insertion This bit enables wakeup event via Card Insertion assertion in the <i>Normal Interrupt Status</i> register. FN_WUS (Wake Up Support) in CIS does not affect this bit.</p> <table border="1"> <tr> <td>1</td> <td>Enable</td> </tr> <tr> <td>0</td> <td>Disable</td> </tr> </table>	1	Enable	0	Disable
1	Enable					
0	Disable					
00	RW	<p>Wakeup Event Enable On Card Interrupt This bit enables wakeup event via Card Interrupt assertion in the <i>Normal Interrupt Status</i> register. This bit can be set to 1 if FN_WUS (Wake Up Support) in CIS is set to 1.</p> <table border="1"> <tr> <td>1</td> <td>Enable</td> </tr> <tr> <td>0</td> <td>Disable</td> </tr> </table>	1	Enable	0	Disable
1	Enable					
0	Disable					

Table 2-19 : Wakeup Control Register

2.2.14 Clock Control Register (Offset 02Ch)

At the initialization of the Host Controller, the Host Driver shall set the **SDCLK Frequency Select** according to the *Capabilities* register.

D15	D08	D07-D06	D05	D04 - D03	D02	D01	D00
SDCLK Frequency Select		Upper Bits of SDCLK Frequency Select	Clock Generator Select	Reserved	SD Clock Enable	Internal Clock Stable	Internal Clock Enable

Figure 2-18 : Clock Control Register

Location	Attrib	Register Field Explanation																		
15-08	RW	<p>SDCLK Frequency Select This register is used to select the frequency of SDCLK pin. The definition of this field is dependent on the Host Controller Version.</p> <p>(1) 8-bit Divided Clock Mode This mode is supported by the Host Controller Version 1.00 and 2.00. The frequency is not programmed directly; rather this register holds the divisor of the Base Clock Frequency For SD Clock in the <i>Capabilities</i> register. Only the following settings are allowed.</p> <table border="1"> <tbody> <tr><td>80h</td><td>base clock divided by 256</td></tr> <tr><td>40h</td><td>base clock divided by 128</td></tr> <tr><td>20h</td><td>base clock divided by 64</td></tr> <tr><td>10h</td><td>base clock divided by 32</td></tr> <tr><td>08h</td><td>base clock divided by 16</td></tr> <tr><td>04h</td><td>base clock divided by 8</td></tr> <tr><td>02h</td><td>base clock divided by 4</td></tr> <tr><td>01h</td><td>base clock divided by 2</td></tr> <tr><td>00h</td><td>Base clock (10MHz-63MHz)</td></tr> </tbody> </table> <p>Setting 00h specifies the highest frequency of the SD Clock. When setting multiple bits, the most significant bit is used as the divisor but it should not be set. The three default divider values can be calculated by the frequency that is defined by the Base Clock Frequency For SD Clock in the <i>Capabilities</i> register. 400KHz divider value 25MHz divider value 50MHz divider value According to the Physical Layer Specification, the maximum SD Clock frequency is 25 MHz in normal speed mode and 50MHz in high speed mode, and shall never exceed this limit. The frequency of SDCLK is set by the following formula:</p> <p style="text-align: center;">Clock Frequency = (Base Clock) / divisor</p>	80h	base clock divided by 256	40h	base clock divided by 128	20h	base clock divided by 64	10h	base clock divided by 32	08h	base clock divided by 16	04h	base clock divided by 8	02h	base clock divided by 4	01h	base clock divided by 2	00h	Base clock (10MHz-63MHz)
80h	base clock divided by 256																			
40h	base clock divided by 128																			
20h	base clock divided by 64																			
10h	base clock divided by 32																			
08h	base clock divided by 16																			
04h	base clock divided by 8																			
02h	base clock divided by 4																			
01h	base clock divided by 2																			
00h	Base clock (10MHz-63MHz)																			

SD Host Controller Simplified Specification Version 3.00

Thus, choose the smallest possible divisor which results in a clock frequency that is less than or equal to the target frequency.
 For example, if the **Base Clock Frequency For SD Clock** in the *Capabilities* register has the value 33MHz, and the target frequency is 25MHz, then choosing the divisor value of 01h will yield 16.5MHz, which is the nearest frequency less than or equal to the target. Similarly, to approach a clock value of 400KHz, the divisor value of 40h yields the optimal clock value of 258KHz.

(2) 10-bit Divided Clock Mode

Host Controller Version 3.00 supports this mandatory mode instead of the 8-bit Divided Clock Mode. The length of divider is extended to 10 bits and all divider values shall be supported.

3FFh	1/2046 Divided Clock
.....
N	1/2N Divided Clock (Duty 50%)
.....
002h	1/4 Divided Clock
001h	1/2 Divided Clock
000h	Base Clock (10MHz-255MHz)

(3) Programmable Clock Mode

Host Controller Version 3.00 supports this mode as optional. A non-zero value set to **Clock Multiplier** in the *Capabilities* register indicates support of this clock mode. The multiplier enables the Host System to select a finer grain SD clock frequency. It is not necessary to support all frequency generation specified by this field because programmable clock generator is vendor specific and dependent on the implementation. Therefore, this mode is used with *Preset Value* registers. The Host Controller vendor provides possible settings and the Host System vendor sets appropriate values to the *Preset Value* registers.

3FFh	Base Clock * M / 1024
.....
N - 1	Base Clock * M / N
.....
002h	Base Clock * M / 3
001h	Base Clock * M / 2
000h	Base Clock * M

This field depends on setting of **Preset Value Enable** in the *Host Control 2* register.

If **Preset Value Enable = 0**, this field is set by Host Driver.

If the **Preset Value Enable = 1**, this field is automatically set to a value specified in one of *Preset Value* registers.

SD Host Controller Simplified Specification Version 3.00

07-06	ROC or RW	<p>Upper Bits of SDCLK Frequency Select Host Controller Version 1.00 and 2.00 do not support these bits and they are treated as 00b fixed value (ROC). Host Controller Version 3.00 shall support these bits to expand SDCLK Frequency Select to 10-bit. Bit 07-06 is assigned to bit 09-08 of clock divider in SDCLK Frequency Select.</p>				
05	RW or ROC	<p>Clock Generator Select Host Controller Version 3.00 supports this bit. This bit is used to select the clock generator mode in SDCLK Frequency Select. If the Programmable Clock Mode is supported (non-zero value is set to Clock Multiplier in the <i>Capabilities</i> register), this bit attribute is RW, and if not supported, this bit attribute is RO and zero is read.</p> <p>This bit depends on the setting of Preset Value Enable in the <i>Host Control 2</i> register. If the Preset Value Enable = 0, this bit is set by Host Driver. If the Preset Value Enable = 1, this bit is automatically set to a value specified in one of <i>Preset Value</i> registers.</p> <table border="1"> <tr> <td>1</td> <td>Programmable Clock Mode</td> </tr> <tr> <td>0</td> <td>Divided Clock Mode</td> </tr> </table>	1	Programmable Clock Mode	0	Divided Clock Mode
1	Programmable Clock Mode					
0	Divided Clock Mode					
04-03		Reserved				
02	RW	<p>SD Clock Enable The Host Controller shall stop SDCLK when writing this bit to 0. SDCLK Frequency Select can be changed when this bit is 0. Then, the Host Controller shall maintain the same clock frequency until SDCLK is stopped (Stop at SDCLK=0). If the Card Inserted in the <i>Present State register</i> is cleared, this bit shall be cleared.</p> <table border="1"> <tr> <td>1</td> <td>Enable</td> </tr> <tr> <td>0</td> <td>Disable</td> </tr> </table>	1	Enable	0	Disable
1	Enable					
0	Disable					
01	ROC	<p>Internal Clock Stable This bit is set to 1 when SD Clock is stable after writing to Internal Clock Enable in this register to 1. The SD Host Driver shall wait to set SD Clock Enable until this bit is set to 1. Note: This is useful when using PLL for a clock oscillator that requires setup time.</p> <table border="1"> <tr> <td>1</td> <td>Ready</td> </tr> <tr> <td>0</td> <td>Not Ready</td> </tr> </table>	1	Ready	0	Not Ready
1	Ready					
0	Not Ready					
00	RW	<p>Internal Clock Enable This bit is set to 0 when the Host Driver is not using the Host Controller or the Host Controller awaits a wakeup interrupt. The Host Controller should stop its internal clock to go very low power state. Still, registers shall be able to be read and written. Clock starts to oscillate when this bit is set to 1. When clock oscillation is stable, the Host Controller shall set Internal Clock Stable in this register to 1. This bit shall not affect card detection.</p> <table border="1"> <tr> <td>1</td> <td>Oscillate</td> </tr> <tr> <td>0</td> <td>Stop</td> </tr> </table>	1	Oscillate	0	Stop
1	Oscillate					
0	Stop					

Table 2-20 : Clock Control Register

2.2.15 Timeout Control Register (Offset 02Eh)

At the initialization of the Host Controller, the Host Driver shall set the **Data Timeout Counter Value** according to the *Capabilities* register.

D07	D04	D03	D00
Rsvd		Data Timeout Counter Value	

Figure 2-19 : Timeout Control Register

Location	Attrib	Register Field Explanation										
07-04	Rsvd	Reserved										
03-00	RW	<p>Data Timeout Counter Value This value determines the interval by which DAT line timeouts are detected. For more information about timeout generation, refer to the Data Timeout Error in the <i>Error Interrupt Status</i> register. Timeout clock frequency will be generated by dividing the base clock TMCLK value by this value. When setting this register, prevent inadvertent timeout events by clearing the Data Timeout Error Status Enable (in the <i>Error Interrupt Status Enable</i> register)</p> <table border="1"> <tr> <td>1111b</td> <td>Reserved</td> </tr> <tr> <td>1110b</td> <td>TMCLK x 2²⁷</td> </tr> <tr> <td>.....</td> <td>.....</td> </tr> <tr> <td>0001b</td> <td>TMCLK x 2¹⁴</td> </tr> <tr> <td>0000b</td> <td>TMCLK x 2¹³</td> </tr> </table>	1111b	Reserved	1110b	TMCLK x 2 ²⁷	0001b	TMCLK x 2 ¹⁴	0000b	TMCLK x 2 ¹³
1111b	Reserved											
1110b	TMCLK x 2 ²⁷											
.....											
0001b	TMCLK x 2 ¹⁴											
0000b	TMCLK x 2 ¹³											

Table 2-21 : Timeout Control Register

Implementation Note:

The Physical Layer Specification Version 3.0x defines that SDXC card may indicate 500ms busy. Then Host Driver may need to change timeout value for SDXC. It is also possible to set more than 500ms timeout regardless of card capacities.

2.2.16 Software Reset Register (Offset 02Fh)

A reset pulse is generated when writing 1 to each bit of this register. After completing the reset, the Host Controller shall clear each bit. Because it takes some time to complete software reset, the SD Host Driver shall confirm that these bits are 0.

D07	D03	D02	D01	D00
Rsvd		Software Reset For DAT Line	Software Reset For CMD Line	Software Reset For All

Figure 2-20 : Software Reset Register

Location	Attrib	Register Field Explanation				
07-03	Rsvd	Reserved				
02	RWAC	<p>Software Reset For DAT Line Only part of data circuit is reset. DMA circuit is also reset.</p> <p>The following registers and bits are cleared by this bit:</p> <p><i>Buffer Data Port</i> register Buffer is cleared and initialized.</p> <p><i>Present State</i> register Buffer Read Enable Buffer Write Enable Read Transfer Active Write Transfer Active DAT Line Active Command Inhibit (DAT)</p> <p><i>Block Gap Control</i> register Continue Request Stop At Block Gap Request</p> <p><i>Normal Interrupt Status</i> register Buffer Read Ready Buffer Write Ready DMA Interrupt Block Gap Event Transfer Complete</p> <table border="1" style="margin-left: auto; margin-right: auto;"> <tr> <td style="text-align: center;">1</td> <td style="text-align: left;">Reset</td> </tr> <tr> <td style="text-align: center;">0</td> <td style="text-align: left;">Work</td> </tr> </table>	1	Reset	0	Work
1	Reset					
0	Work					

SD Host Controller Simplified Specification Version 3.00

01	RWAC	<p>Software Reset For CMD Line Only part of command circuit is reset.</p> <p>The following registers and bits are cleared by this bit: <i>Present State</i> register Command Inhibit (CMD) <i>Normal Interrupt Status</i> register Command Complete</p> <table border="1" data-bbox="459 478 711 546"> <tr> <td>1</td> <td>Reset</td> </tr> <tr> <td>0</td> <td>Work</td> </tr> </table>	1	Reset	0	Work
1	Reset					
0	Work					
00	RWAC	<p>Software Reset For All This reset affects the entire Host Controller except for the card detection circuit. Register bits of type ROC, RW, RW1C, RWAC are cleared to 0. During its initialization, the Host Driver shall set this bit to 1 to reset the Host Controller. The Host Controller shall reset this bit to 0 when <i>Capabilities</i> registers are valid and the Host Driver can read them. Additional use of Software Reset For All may not affect the value of the <i>Capabilities</i> registers. If this bit is set to 1, the host driver should issue reset command and reinitialize the SD card.</p> <table border="1" data-bbox="459 835 711 898"> <tr> <td>1</td> <td>Reset</td> </tr> <tr> <td>0</td> <td>Work</td> </tr> </table>	1	Reset	0	Work
1	Reset					
0	Work					

Table 2-22 : Software Reset Register

2.2.17 Normal Interrupt Status Register (Offset 030h)

The *Normal Interrupt Status Enable* affects reads of this register, but *Normal Interrupt Signal Enable* does not affect these reads. An interrupt is generated when the Normal Interrupt Signal Enable is enabled and at least one of the status bits is set to 1. Writing 1 to a bit of RW1C attribute clears it; writing 0 keeps the bit unchanged. Writing 1 to a bit of ROC attribute keeps the bit unchanged. More than one status can be cleared with a single register write. The **Card Interrupt** is cleared when the card stops asserting the interrupt; that is, when the Card Driver services the interrupt condition.

D15	D14 - D13	D12	D11	D10	D09	D08	D07	D06	D05	D04	D03	D02	D01	D00
Error Interrupt	Rsvd	Re-Tuning Event	INT_C	INT_B	INT_A	Card Interrupt	Card Removal	Card Insertion	Buffer Read Ready	Buffer Write Ready	DMA Interrupt	Block Gap Event	Transfer Complete	Command Complete

Figure 2-21 : Normal Interrupt Status Register

Location	Attrib	Register Field Explanation				
15	ROC	<p>Error Interrupt If any of the bits in the <i>Error Interrupt Status</i> register are set, then this bit is set. Therefore the Host Driver can efficiently test for an error by checking this bit first. This bit is read only.</p> <table border="1"> <tr> <td>1</td> <td>Error</td> </tr> <tr> <td>0</td> <td>No Error</td> </tr> </table>	1	Error	0	No Error
1	Error					
0	No Error					
14-13	Rsvd	Reserved				
12	ROC	<p>Re-Tuning Event This status is set if Re-Tuning Request in the <i>Present State</i> register changes from 0 to 1. Host Controller requests Host Driver to perform re-tuning for next data transfer. Current data transfer (not large block count) can be completed without re-tuning.</p> <table border="1"> <tr> <td>1</td> <td>Re-Tuning should be performed</td> </tr> <tr> <td>0</td> <td>Re-Tuning is not required</td> </tr> </table>	1	Re-Tuning should be performed	0	Re-Tuning is not required
1	Re-Tuning should be performed					
0	Re-Tuning is not required					
11	ROC	<p>INT_C This status is set if INT_C is enabled and INT_C# pin is in low level. Writing this bit to 1 does not clear this bit. It is cleared by resetting the INT_C interrupt factor. Refer to the Shared Bus Control register.</p> <table border="1"> <tr> <td>1</td> <td>INT_C is detected</td> </tr> <tr> <td>0</td> <td>No interrupt is detected</td> </tr> </table>	1	INT_C is detected	0	No interrupt is detected
1	INT_C is detected					
0	No interrupt is detected					
10	ROC	<p>INT_B This status is set if INT_B is enabled and INT_B# pin is in low level. Writing this bit to 1 does not clear this bit. It is cleared by resetting the INT_B interrupt factor. Refer to the Shared Bus Control register.</p> <table border="1"> <tr> <td>1</td> <td>INT_B is detected</td> </tr> <tr> <td>0</td> <td>No interrupt is detected</td> </tr> </table>	1	INT_B is detected	0	No interrupt is detected
1	INT_B is detected					
0	No interrupt is detected					

SD Host Controller Simplified Specification Version 3.00

09	ROC	<p>INT_A This status is set if INT_A is enabled and INT_A# pin is in low level. Writing this bit to 1 does not clear this bit. It is cleared by resetting the INT_A interrupt factor. Refer to the Shared Bus Control register.</p> <table border="1" data-bbox="516 348 1109 415"> <tr> <td>1</td> <td>INT_A is detected</td> </tr> <tr> <td>0</td> <td>No interrupt is detected</td> </tr> </table>	1	INT_A is detected	0	No interrupt is detected
1	INT_A is detected					
0	No interrupt is detected					
08	ROC	<p>Card Interrupt Writing this bit to 1 does not clear this bit. It is cleared by resetting the SD card interrupt factor. In 1-bit mode, the Host Controller shall detect the Card Interrupt without SD Clock to support wakeup. In 4-bit mode, the card interrupt signal is sampled during the interrupt cycle, so there are some sample delays between the interrupt signal from the SD card and the interrupt to the Host System. When this status has been set and the Host Driver needs to start this interrupt service, Card Interrupt Status Enable in the <i>Normal Interrupt Status Enable</i> register may be set to 0 in order to clear the card interrupt statuses latched in the Host Controller and to stop driving the interrupt signal to the Host System. After completion of the card interrupt service (It should reset interrupt factors in the SD card and the interrupt signal may not be asserted), set Card Interrupt Status Enable to 1 and start sampling the interrupt signal again.</p> <p>Interrupt detected by DAT[1] is supported when there is a card per slot. In case of shared bus, interrupt pins are used to detect interrupts. If 000b is set to Interrupt Pin Select in the <i>Shared Bus Control</i> register, this status is effective. Non-zero value is set to Interrupt Pin Select, INT_A, INT_B or INT_C is then used to device interrupts.</p> <table border="1" data-bbox="516 1119 992 1188"> <tr> <td>1</td> <td>Generate Card Interrupt</td> </tr> <tr> <td>0</td> <td>No Card Interrupt</td> </tr> </table>	1	Generate Card Interrupt	0	No Card Interrupt
1	Generate Card Interrupt					
0	No Card Interrupt					
07	RW1C	<p>Card Removal This status is set if the Card Inserted in the <i>Present State</i> register changes from 1 to 0. When the Host Driver writes this bit to 1 to clear this status, the status of the Card Inserted in the <i>Present State</i> register should be confirmed. Because the card detect state may possibly be changed when the Host Driver clear this bit and interrupt event may not be generated.</p> <table border="1" data-bbox="516 1444 1094 1514"> <tr> <td>1</td> <td>Card removed</td> </tr> <tr> <td>0</td> <td>Card state stable or Debouncing</td> </tr> </table>	1	Card removed	0	Card state stable or Debouncing
1	Card removed					
0	Card state stable or Debouncing					
06	RW1C	<p>Card Insertion This status is set if the Card Inserted in the <i>Present State</i> register changes from 0 to 1. When the Host Driver writes this bit to 1 to clear this status, the status of the Card Inserted in the <i>Present State</i> register should be confirmed. Because the card detect state may possibly be changed when the Host Driver clear this bit and interrupt event may not be generated.</p> <table border="1" data-bbox="516 1766 1094 1829"> <tr> <td>1</td> <td>Card inserted</td> </tr> <tr> <td>0</td> <td>Card state stable or Debouncing</td> </tr> </table>	1	Card inserted	0	Card state stable or Debouncing
1	Card inserted					
0	Card state stable or Debouncing					

SD Host Controller Simplified Specification Version 3.00

05	RW1C	<p>Buffer Read Ready This status is set if the Buffer Read Enable changes from 0 to 1. Refer to the Buffer Read Enable in the <i>Present State</i> register. While performing tuning procedure (Execute Tuning is set to 1), Buffer Read Ready is set to 1 for every CMD19 execution.</p> <table border="1" data-bbox="516 380 987 447"> <tr> <td>1</td> <td>Ready to read buffer</td> </tr> <tr> <td>0</td> <td>Not ready to read buffer</td> </tr> </table>	1	Ready to read buffer	0	Not ready to read buffer
1	Ready to read buffer					
0	Not ready to read buffer					
04	RW1C	<p>Buffer Write Ready This status is set if the Buffer Write Enable changes from 0 to 1. Refer to the Buffer Write Enable in the <i>Present State</i> register.</p> <table border="1" data-bbox="516 575 987 642"> <tr> <td>1</td> <td>Ready to write buffer</td> </tr> <tr> <td>0</td> <td>Not ready to write buffer</td> </tr> </table>	1	Ready to write buffer	0	Not ready to write buffer
1	Ready to write buffer					
0	Not ready to write buffer					
03	RW1C	<p>DMA Interrupt This status is set if the Host Controller detects the Host SDMA Buffer boundary during transfer. Refer to the Host SDMA Buffer Boundary in the <i>Block Size</i> register. Other DMA interrupt factors may be added in the future. In case of ADMA, by setting Int field in the descriptor table, Host Controller generates this interrupt. Suppose that it is used for debugging. This interrupt shall not be generated after the Transfer Complete.</p> <table border="1" data-bbox="516 930 1105 997"> <tr> <td>1</td> <td>DMA Interrupt is generated</td> </tr> <tr> <td>0</td> <td>No DMA Interrupt</td> </tr> </table>	1	DMA Interrupt is generated	0	No DMA Interrupt
1	DMA Interrupt is generated					
0	No DMA Interrupt					
02	RW1C	<p>Block Gap Event If the Stop At Block Gap Request in the <i>Block Gap Control</i> register is set, this bit is set when both a read / write transaction is stopped at a block gap. If Stop At Block Gap Request is not set to 1, this bit is not set to 1.</p> <p>(1) In the case of a Read Transaction This bit is set at the falling edge of the DAT Line Active Status (When the transaction is stopped at SD Bus timing. The Read Wait shall be supported in order to use this function. Refer to Section 3.12.3 about the detail timing.</p> <p>(2) Case of Write Transaction This bit is set at the falling edge of Write Transfer Active Status (After getting CRC status at SD Bus timing). Refer to Section 3.12.4 for more details on the sequence of events.</p> <table border="1" data-bbox="516 1478 1101 1545"> <tr> <td>1</td> <td>Transaction stopped at block gap</td> </tr> <tr> <td>0</td> <td>No Block Gap Event</td> </tr> </table>	1	Transaction stopped at block gap	0	No Block Gap Event
1	Transaction stopped at block gap					
0	No Block Gap Event					
01	RW1C	<p>Transfer Complete This bit is set when a read / write transfer and a command with busy is completed.</p> <p>(1) In the case of a Read Transaction This bit is set at the falling edge of Read Transfer Active Status. This interrupt is generated in two cases. The first is when a data transfer is completed as specified by data length (After the last data has been read to the Host System). The second is when data has stopped at the block gap and completed the data transfer by setting</p>				

		<p>the Stop At Block Gap Request in the <i>Block Gap Control</i> register (After valid data has been read to the Host System). Refer to Section 3.12.3 for more details on the sequence of events.</p> <p>(2) In the case of a Write Transaction This bit is set at the falling edge of the DAT Line Active Status. This interrupt is generated in two cases. The first is when the last data is written to the SD card as specified by data length and the busy signal released. The second is when data transfers are stopped at the block gap by setting Stop At Block Gap Request in the <i>Block Gap Control</i> register and data transfers completed. (After valid data is written to the SD card and the busy signal released). Refer to Section 3.12.4 for more details on the sequence of events.</p> <p>(3) In the case of a command with busy This bit is set when busy is de-asserted. Refer to DAT Line Active and Command Inhibit (DAT) in the <i>Present State</i> register.</p> <p>The table below shows that Transfer Complete has higher priority than Data Timeout Error. If both bits are set to 1, execution of a command can be considered to be completed.</p> <p>Relation between Transfer Complete and Data Timeout Error</p> <table border="1" data-bbox="516 863 1377 1037"> <thead> <tr> <th>Transfer Complete</th> <th>Data Timeout Error</th> <th>Meaning of the status</th> </tr> </thead> <tbody> <tr> <td>0</td> <td>0</td> <td>Interrupted by another factor</td> </tr> <tr> <td>0</td> <td>1</td> <td>Timeout occur during transfer</td> </tr> <tr> <td>1</td> <td>Don't Care</td> <td>Command Execution complete</td> </tr> </tbody> </table> <table border="1" data-bbox="516 1066 1214 1136"> <tbody> <tr> <td>1</td> <td>Command execution is completed</td> </tr> <tr> <td>0</td> <td>Not complete</td> </tr> </tbody> </table> <p>While performing tuning procedure (Execute Tuning is set to 1), Transfer Complete is not set to 1.</p>	Transfer Complete	Data Timeout Error	Meaning of the status	0	0	Interrupted by another factor	0	1	Timeout occur during transfer	1	Don't Care	Command Execution complete	1	Command execution is completed	0	Not complete
Transfer Complete	Data Timeout Error	Meaning of the status																
0	0	Interrupted by another factor																
0	1	Timeout occur during transfer																
1	Don't Care	Command Execution complete																
1	Command execution is completed																	
0	Not complete																	

00	RW1C	<p>Command Complete</p> <p>This bit is set when get the end bit of the command response. Auto CMD12 and Auto CMD23 consist of two responses. Command Complete is not generated by the response of CMD12 or CMD23 but generated by the response of a read/write command.</p> <p>Refer to Command Inhibit (CMD) in the <i>Present State</i> register for how to control this bit.</p> <p>The table below shows that Command Timeout Error has higher priority than Command Complete. If both bits are set to 1, it can be considered that the response was not received correctly.</p> <table border="1" data-bbox="516 575 1352 779"> <thead> <tr> <th>Command Complete</th> <th>Command Timeout Error</th> <th>Meaning of the status</th> </tr> </thead> <tbody> <tr> <td>0</td> <td>0</td> <td>Interrupted by another factor</td> </tr> <tr> <td>Don't Care</td> <td>1</td> <td>Response not received within 64 SDCLK cycles.</td> </tr> <tr> <td>1</td> <td>0</td> <td>Response received</td> </tr> </tbody> </table> <table border="1" data-bbox="516 814 982 875"> <tbody> <tr> <td>1</td> <td>Command complete</td> </tr> <tr> <td>0</td> <td>No command complete</td> </tr> </tbody> </table>	Command Complete	Command Timeout Error	Meaning of the status	0	0	Interrupted by another factor	Don't Care	1	Response not received within 64 SDCLK cycles.	1	0	Response received	1	Command complete	0	No command complete
Command Complete	Command Timeout Error	Meaning of the status																
0	0	Interrupted by another factor																
Don't Care	1	Response not received within 64 SDCLK cycles.																
1	0	Response received																
1	Command complete																	
0	No command complete																	

Table 2-23 : Normal Interrupt Status Register

2.2.18 Error Interrupt Status Register (Offset 032h)

Signals defined in this register can be enabled by the *Error Interrupt Status Enable* register, but not by the *Error Interrupt Signal Enable* register. The interrupt is generated when the *Error Interrupt Signal Enable* is enabled and at least one of the statuses is set to 1. Writing to 1 clears the bit and writing to 0 keeps the bit unchanged. More than one status can be cleared at the one register write.

D15	D12	D11	D10	D09	D08	D07	D06	D05	D04	D03	D02	D01	D00
Vendor Specific Error Status		Rsvd	Tuning Error	ADMA Error	Auto CMD12 Error	Current limit Error	Data End Bit Error	Data CRC Error	Data Timeout Error	Command Index Error	Command End Bit Error	Command CRC Error	Command Timeout Error

Figure 2-22 : Error Interrupt Status Register

Location	Attrib	Register Field Explanation				
15-12	RW1C	Vendor Specific Error Status Additional status bits can be defined in this register by the vendor.				
11	Rsvd	Reserved				
10	RW1C	<p>Tuning Error This bit is set when an unrecoverable error is detected in a tuning circuit except during tuning procedure (Occurrence of an error during tuning procedure is indicated by Sampling Select). By detecting Tuning Error, Host Driver needs to abort a command executing and perform tuning. To reset tuning circuit, Sampling Clock shall be set to 0 before executing tuning procedure (Refer to Figure 2-29). The Tuning Error is higher priority than the other error interrupts generated during data transfer. By detecting Tuning Error, the Host Driver should discard data transferred by a current read/write command and retry data transfer after the Host Controller retrieved from tuning circuit error.</p> <table border="1"> <tr> <td>1</td> <td>Error</td> </tr> <tr> <td>0</td> <td>No Error</td> </tr> </table>	1	Error	0	No Error
1	Error					
0	No Error					
09	RW1C	<p>ADMA Error This bit is set when the Host Controller detects errors during ADMA based data transfer. The state of the ADMA at an error occurrence is saved in the <i>ADMA Error Status Register</i>, In addition, the Host Controller generates this Interrupt when it detects invalid descriptor data (Valid=0) at the ST_FDS state. ADMA Error State in the <i>ADMA Error Status</i> indicates that an error occurs in ST_FDS state. The Host Driver may find that Valid bit is not set at the error descriptor.</p> <table border="1"> <tr> <td>1</td> <td>Error</td> </tr> <tr> <td>0</td> <td>No Error</td> </tr> </table>	1	Error	0	No Error
1	Error					
0	No Error					

SD Host Controller Simplified Specification Version 3.00

08	RW1C	<p>Auto CMD Error Auto CMD12 and Auto CMD23 use this error status. This bit is set when detecting that one of the bits D00-D04 in <i>Auto CMD Error Status</i> register has changed from 0 to 1. In case of Auto CMD12, this bit is set to 1, not only when the errors in Auto CMD12 occur but also when Auto CMD12 is not executed due to the previous command error.</p> <table border="1"> <tr> <td>1</td> <td>Error</td> </tr> <tr> <td>0</td> <td>No Error</td> </tr> </table>	1	Error	0	No Error
1	Error					
0	No Error					
07	RW1C	<p>Current Limit Error By setting the SD Bus Power bit in the <i>Power Control</i> register, the Host Controller is requested to supply power for the SD Bus. If the Host Controller supports the Current Limit function, it can be protected from an illegal card by stopping power supply to the card in which case this bit indicates a failure status. Reading 1 means the Host Controller is not supplying power to SD card due to some failure. Reading 0 means that the Host Controller is supplying power and no error has occurred. The Host Controller may require some sampling time to detect the current limit. If the Host Controller does not support this function, this bit shall always be set to 0.</p> <table border="1"> <tr> <td>1</td> <td>Power fail</td> </tr> <tr> <td>0</td> <td>No Error</td> </tr> </table>	1	Power fail	0	No Error
1	Power fail					
0	No Error					
06	RW1C	<p>Data End Bit Error Occurs either when detecting 0 at the end bit position of read data which uses the DAT line or at the end bit position of the CRC Status.</p> <table border="1"> <tr> <td>1</td> <td>Error</td> </tr> <tr> <td>0</td> <td>No Error</td> </tr> </table>	1	Error	0	No Error
1	Error					
0	No Error					
05	RW1C	<p>Data CRC Error Occurs when detecting CRC error when transferring read data which uses the DAT line or when detecting the Write CRC status having a value of other than "010".</p> <table border="1"> <tr> <td>1</td> <td>Error</td> </tr> <tr> <td>0</td> <td>No Error</td> </tr> </table>	1	Error	0	No Error
1	Error					
0	No Error					
04	RW1C	<p>Data Timeout Error This bit is set when detecting one of following timeout conditions. (1) Busy timeout for R1b,R5b type (2) Busy timeout after Write CRC status (3) Write CRC Status timeout (4) Read Data timeout.</p> <table border="1"> <tr> <td>1</td> <td>Time out</td> </tr> <tr> <td>0</td> <td>No Error</td> </tr> </table>	1	Time out	0	No Error
1	Time out					
0	No Error					
03	RW1C	<p>Command Index Error This bit is set if a Command Index error occurs in the command response.</p> <table border="1"> <tr> <td>1</td> <td>Error</td> </tr> <tr> <td>0</td> <td>No Error</td> </tr> </table>	1	Error	0	No Error
1	Error					
0	No Error					

SD Host Controller Simplified Specification Version 3.00

02	RW1C	<p>Command End Bit Error This bit is set when detecting that the end bit of a command response is 0.</p> <table border="1"> <tr> <td>1</td> <td>End Bit Error Generated</td> </tr> <tr> <td>0</td> <td>No Error</td> </tr> </table>	1	End Bit Error Generated	0	No Error
1	End Bit Error Generated					
0	No Error					
01	RW1C	<p>Command CRC Error Command CRC Error is generated in two cases. If a response is returned and the Command Timeout Error is set to 0 (indicating no timeout), this bit is set to 1 when detecting a CRC error in the command response. The Host Controller detects a CMD line conflict by monitoring the CMD line when a command is issued. If the Host Controller drives the CMD line to 1 level, but detects 0 level on the CMD line at the next SD clock edge, then the Host Controller shall abort the command (Stop driving CMD line) and set this bit to 1. The Command Timeout Error shall also be set to 1 to distinguish CMD line conflict (Refer to Table 2-25).</p> <table border="1"> <tr> <td>1</td> <td>CRC Error Generated.</td> </tr> <tr> <td>0</td> <td>No Error</td> </tr> </table>	1	CRC Error Generated.	0	No Error
1	CRC Error Generated.					
0	No Error					
00	RW1C	<p>Command Timeout Error This bit is set only if no response is returned within 64 SD clock cycles from the end bit of the command. If the Host Controller detects a CMD line conflict, in which case Command CRC Error shall also be set as shown in Table 2-25, this bit shall be set without waiting for 64 SD clock cycles because the command will be aborted by the Host Controller.</p> <table border="1"> <tr> <td>1</td> <td>Time out</td> </tr> <tr> <td>0</td> <td>No Error</td> </tr> </table>	1	Time out	0	No Error
1	Time out					
0	No Error					

Table 2-24 : Error Interrupt Status Register

The relation between **Command CRC Error** and **Command Timeout Error** is shown in Table 2-25.

Command CRC Error	Command Timeout Error	Kinds of error
0	0	No Error
0	1	Response Timeout Error
1	0	Response CRC Error
1	1	CMD line conflict

Table 2-25 : The Relation between Command CRC Error and Command Timeout Error

2.2.19 Normal Interrupt Status Enable Register (Offset 034h)

Setting to 1 enables Interrupt Status.

D15	D14 - D13	D12	D11	D10	D09	D08	D07	D06	D05	D04	D03	D02	D01	D00
Fixed to 0	Rsvd	Re-Tuning Event Status Enable	INT_C Status Enable	INT_B Status Enable	INT_A Status Enable	Card Interrupt Status Enable	Card Removal Status Enable	Card Insertion Status Enable	Buffer Read Ready Status Enable	Buffer Write Ready Status Enable	DMA Interrupt Status Enable	Block Gap Event Status Enable	Transfer Complete Status Enable	Command Complete Status Enable

Figure 2-23 : Normal Interrupt Status Enable Register

Location	Attrib	Register Field Explanation				
15	RO	Fixed to 0 The Host Driver shall control error interrupts using the <i>Error Interrupt Status Enable</i> register.				
14-13	Rsvd	Reserved				
12	RW	Re-Tuning Event Status Enable <table border="1"> <tr> <td>1</td> <td>Enabled</td> </tr> <tr> <td>0</td> <td>Masked</td> </tr> </table>	1	Enabled	0	Masked
1	Enabled					
0	Masked					
11	RW	INT_C Status Enable If this bit is set to 0, the Host Controller shall clear the interrupt request to the System. The Host Driver may clear this bit before servicing the INT_C and may set this bit again after all interrupt requests to INT_C pin are cleared to prevent inadvertent interrupts. <table border="1"> <tr> <td>1</td> <td>Enabled</td> </tr> <tr> <td>0</td> <td>Masked</td> </tr> </table>	1	Enabled	0	Masked
1	Enabled					
0	Masked					
10	RW	INT_B Status Enable If this bit is set to 0, the Host Controller shall clear the interrupt request to the System. The Host Driver may clear this bit before servicing the INT_B and may set this bit again after all interrupt requests to INT_B pin are cleared to prevent inadvertent interrupts. <table border="1"> <tr> <td>1</td> <td>Enabled</td> </tr> <tr> <td>0</td> <td>Masked</td> </tr> </table>	1	Enabled	0	Masked
1	Enabled					
0	Masked					
09	RW	INT_A Status Enable If this bit is set to 0, the Host Controller shall clear the interrupt request to the System. The Host Driver may clear this bit before servicing the INT_A and may set this bit again after all interrupt requests to INT_A pin are cleared to prevent inadvertent interrupts. <table border="1"> <tr> <td>1</td> <td>Enabled</td> </tr> <tr> <td>0</td> <td>Masked</td> </tr> </table>	1	Enabled	0	Masked
1	Enabled					
0	Masked					

SD Host Controller Simplified Specification Version 3.00

08	RW	<p>Card Interrupt Status Enable</p> <p>If this bit is set to 0, the Host Controller shall clear interrupt request to the System. The Card Interrupt detection is stopped when this bit is cleared and restarted when this bit is set to 1. The Host Driver may clear the Card Interrupt Status Enable before servicing the Card Interrupt and may set this bit again after all interrupt requests from the card are cleared to prevent inadvertent interrupts.</p> <table border="1"> <tr> <td>1</td> <td>Enabled</td> </tr> <tr> <td>0</td> <td>Masked</td> </tr> </table>	1	Enabled	0	Masked
1	Enabled					
0	Masked					
07	RW	<p>Card Removal Status Enable</p> <table border="1"> <tr> <td>1</td> <td>Enabled</td> </tr> <tr> <td>0</td> <td>Masked</td> </tr> </table>	1	Enabled	0	Masked
1	Enabled					
0	Masked					
06	RW	<p>Card Insertion Status Enable</p> <table border="1"> <tr> <td>1</td> <td>Enabled</td> </tr> <tr> <td>0</td> <td>Masked</td> </tr> </table>	1	Enabled	0	Masked
1	Enabled					
0	Masked					
05	RW	<p>Buffer Read Ready Status Enable</p> <table border="1"> <tr> <td>1</td> <td>Enabled</td> </tr> <tr> <td>0</td> <td>Masked</td> </tr> </table>	1	Enabled	0	Masked
1	Enabled					
0	Masked					
04	RW	<p>Buffer Write Ready Status Enable</p> <table border="1"> <tr> <td>1</td> <td>Enabled</td> </tr> <tr> <td>0</td> <td>Masked</td> </tr> </table>	1	Enabled	0	Masked
1	Enabled					
0	Masked					
03	RW	<p>DMA Interrupt Status Enable</p> <table border="1"> <tr> <td>1</td> <td>Enabled</td> </tr> <tr> <td>0</td> <td>Masked</td> </tr> </table>	1	Enabled	0	Masked
1	Enabled					
0	Masked					
02	RW	<p>Block Gap Event Status Enable</p> <table border="1"> <tr> <td>1</td> <td>Enabled</td> </tr> <tr> <td>0</td> <td>Masked</td> </tr> </table>	1	Enabled	0	Masked
1	Enabled					
0	Masked					
01	RW	<p>Transfer Complete Status Enable</p> <table border="1"> <tr> <td>1</td> <td>Enabled</td> </tr> <tr> <td>0</td> <td>Masked</td> </tr> </table>	1	Enabled	0	Masked
1	Enabled					
0	Masked					
00	RW	<p>Command Complete Status Enable</p> <table border="1"> <tr> <td>1</td> <td>Enabled</td> </tr> <tr> <td>0</td> <td>Masked</td> </tr> </table>	1	Enabled	0	Masked
1	Enabled					
0	Masked					

Table 2-26 : Normal Interrupt Status Enable Register**Implementation Note:**

The Host Controller may sample the card interrupt signal during interrupt period and may hold its value in the flip-flop. If the **Card Interrupt Status Enable** is set to 0, the Host Controller shall clear all internal signals regarding Card Interrupt.

SD Host Controller Simplified Specification Version 3.00**2.2.20 Error Interrupt Status Enable Register (Offset 036h)**

Setting to 1 enables Interrupt Status.

D15	D12	D11	D10	D09	D08	D07	D06	D05	D04	D03	D02	D01	D00
Vendor Specific Error Status Enable		Rsvd	Tuning Error Status Enable	ADMA Error Status Enable	Auto CMD Error Status Enable	Current Limit Error Status Enable	Data End Bit Error Status Enable	Data CRC Error Status Enable	Data Timeout Error Status Enable	Command Index Error Status Enable	Command End Bit Error Status Enable	Command CRC Error Status Enable	Command Timeout Error Status Enable

Figure 2-24 : Error Interrupt Status Enable Register

Location	Attrib	Register Field Explanation				
15-12	RW	Vendor Specific Error Status Enable <table border="1"> <tr> <td>1</td> <td>Enabled</td> </tr> <tr> <td>0</td> <td>Masked</td> </tr> </table>	1	Enabled	0	Masked
1	Enabled					
0	Masked					
11	Rsvd	Reserved				
10	RW	Tuning Error Status Enable <table border="1"> <tr> <td>1</td> <td>Enabled</td> </tr> <tr> <td>0</td> <td>Masked</td> </tr> </table>	1	Enabled	0	Masked
1	Enabled					
0	Masked					
09	RW	ADMA Error Status Enable <table border="1"> <tr> <td>1</td> <td>Enabled</td> </tr> <tr> <td>0</td> <td>Masked</td> </tr> </table>	1	Enabled	0	Masked
1	Enabled					
0	Masked					
08	RW	Auto CMD Error Status Enable <table border="1"> <tr> <td>1</td> <td>Enabled</td> </tr> <tr> <td>0</td> <td>Masked</td> </tr> </table>	1	Enabled	0	Masked
1	Enabled					
0	Masked					
07	RW	Current Limit Error Status Enable <table border="1"> <tr> <td>1</td> <td>Enabled</td> </tr> <tr> <td>0</td> <td>Masked</td> </tr> </table>	1	Enabled	0	Masked
1	Enabled					
0	Masked					
06	RW	Data End Bit Error Status Enable <table border="1"> <tr> <td>1</td> <td>Enabled</td> </tr> <tr> <td>0</td> <td>Masked</td> </tr> </table>	1	Enabled	0	Masked
1	Enabled					
0	Masked					
05	RW	Data CRC Error Status Enable <table border="1"> <tr> <td>1</td> <td>Enabled</td> </tr> <tr> <td>0</td> <td>Masked</td> </tr> </table>	1	Enabled	0	Masked
1	Enabled					
0	Masked					
04	RW	Data Timeout Error Status Enable <table border="1"> <tr> <td>1</td> <td>Enabled</td> </tr> <tr> <td>0</td> <td>Masked</td> </tr> </table>	1	Enabled	0	Masked
1	Enabled					
0	Masked					
03	RW	Command Index Error Status Enable <table border="1"> <tr> <td>1</td> <td>Enabled</td> </tr> <tr> <td>0</td> <td>Masked</td> </tr> </table>	1	Enabled	0	Masked
1	Enabled					
0	Masked					

SD Host Controller Simplified Specification Version 3.00

02	RW	Command End Bit Error Status Enable	
		1	Enabled
		0	Masked
01	RW	Command CRC Error Status Enable	
		1	Enabled
		0	Masked
00	RW	Command Timeout Error Status Enable	
		1	Enabled
		0	Masked

Table 2-27 : Error Interrupt Status Enable Register

Implementation Note: To detect CMD line conflict, the Host Driver must set both **Command Timeout Error Status Enable** and **Command CRC Error Status Enable** to 1.

SD Host Controller Simplified Specification Version 3.00**2.2.21 Normal Interrupt Signal Enable Register (Offset 038h)**

This register is used to select which interrupt status is indicated to the Host System as the interrupt. These status bits all share the same 1 bit interrupt line. Setting any of these bits to 1 enables interrupt generation.

D15	D14 - D13	D12	D11	D10	D09	D08	D07	D06	D05	D04	D03	D02	D01	D00
Fixed to 0	Rsvd	Re-Tuning Event Signal Enable	INT_C Signal Enable	INT_B Signal Enable	INT_A Signal Enable	Card Interrupt Signal Enable	Card Removal Signal Enable	Card Insertion Signal Enable	Buffer Read Ready Signal Enable	Buffer Write Ready Signal Enable	DMA Interrupt Signal Enable	Block Gap Event Signal Enable	Transfer Complete Signal Enable	Command Complete Signal Enable

Figure 2-25 : Normal Interrupt Signal Enable Register

Location	Attrib	Register Field Explanation				
15	RO	Fixed to 0 The Host Driver shall control error interrupts using the <i>Error Interrupt Signal Enable</i> register.				
14-13	Rsvd	Reserved				
12	RW	Re-Tuning Event Signal Enable <table border="1"> <tr> <td>1</td> <td>Enabled</td> </tr> <tr> <td>0</td> <td>Masked</td> </tr> </table>	1	Enabled	0	Masked
1	Enabled					
0	Masked					
11	RW	INT_C Signal Enable <table border="1"> <tr> <td>1</td> <td>Enabled</td> </tr> <tr> <td>0</td> <td>Masked</td> </tr> </table>	1	Enabled	0	Masked
1	Enabled					
0	Masked					
10	RW	INT_B Signal Enable <table border="1"> <tr> <td>1</td> <td>Enabled</td> </tr> <tr> <td>0</td> <td>Masked</td> </tr> </table>	1	Enabled	0	Masked
1	Enabled					
0	Masked					
09	RW	INT_A Signal Enable <table border="1"> <tr> <td>1</td> <td>Enabled</td> </tr> <tr> <td>0</td> <td>Masked</td> </tr> </table>	1	Enabled	0	Masked
1	Enabled					
0	Masked					
08	RW	Card Interrupt Signal Enable <table border="1"> <tr> <td>1</td> <td>Enabled</td> </tr> <tr> <td>0</td> <td>Masked</td> </tr> </table>	1	Enabled	0	Masked
1	Enabled					
0	Masked					
07	RW	Card Removal Signal Enable <table border="1"> <tr> <td>1</td> <td>Enabled</td> </tr> <tr> <td>0</td> <td>Masked</td> </tr> </table>	1	Enabled	0	Masked
1	Enabled					
0	Masked					
06	RW	Card Insertion Signal Enable <table border="1"> <tr> <td>1</td> <td>Enabled</td> </tr> <tr> <td>0</td> <td>Masked</td> </tr> </table>	1	Enabled	0	Masked
1	Enabled					
0	Masked					
05	RW	Buffer Read Ready Signal Enable <table border="1"> <tr> <td>1</td> <td>Enabled</td> </tr> <tr> <td>0</td> <td>Masked</td> </tr> </table>	1	Enabled	0	Masked
1	Enabled					
0	Masked					

SD Host Controller Simplified Specification Version 3.00

04	RW	Buffer Write Ready Signal Enable				
		<table border="1"> <tr> <td>1</td> <td>Enabled</td> </tr> <tr> <td>0</td> <td>Masked</td> </tr> </table>	1	Enabled	0	Masked
1	Enabled					
0	Masked					
03	RW	DMA Interrupt Signal Enable				
		<table border="1"> <tr> <td>1</td> <td>Enabled</td> </tr> <tr> <td>0</td> <td>Masked</td> </tr> </table>	1	Enabled	0	Masked
1	Enabled					
0	Masked					
02	RW	Block Gap Event Signal Enable				
		<table border="1"> <tr> <td>1</td> <td>Enabled</td> </tr> <tr> <td>0</td> <td>Masked</td> </tr> </table>	1	Enabled	0	Masked
1	Enabled					
0	Masked					
01	RW	Transfer Complete Signal Enable				
		<table border="1"> <tr> <td>1</td> <td>Enabled</td> </tr> <tr> <td>0</td> <td>Masked</td> </tr> </table>	1	Enabled	0	Masked
1	Enabled					
0	Masked					
00	RW	Command Complete Signal Enable				
		<table border="1"> <tr> <td>1</td> <td>Enabled</td> </tr> <tr> <td>0</td> <td>Masked</td> </tr> </table>	1	Enabled	0	Masked
1	Enabled					
0	Masked					

Table 2-28 : Normal Interrupt Signal Enable Register

2.2.22 Error Interrupt Signal Enable Register (Offset 03Ah)

This register is used to select which interrupt status is notified to the Host System as the interrupt. These status bits all share the same 1 bit interrupt line. Setting any of these bits to 1 enables interrupt generation.

D15	D12	D11	D10	D09	D08	D07	D06	D05	D04	D03	D02	D01	D00
Vendor Specific Error Signal		Rsvd	Tuning Error Signal Enable	ADMA Error Signal Enable	Auto CMD Error Signal Enable	Current Limit Error Signal Enable	Data End Bit Error Signal Enable	Data CRC Error Signal Enable	Data Timeout Error Signal Enable	Command Index Error Signal Enable	Command End Bit Error Signal Enable	Command CRC Error Signal Enable	Command Timeout Error Signal Enable

Figure 2-26 : Error Interrupt Signal Enable Register

Location	Attrib	Register Field Explanation				
15-12	RW	Vendor Specific Error Signal Enable <table border="1"> <tr> <td>1</td> <td>Enabled</td> </tr> <tr> <td>0</td> <td>Masked</td> </tr> </table>	1	Enabled	0	Masked
1	Enabled					
0	Masked					
11	Rsvd	Reserved				
10	RW	Tuning Error Signal Enable <table border="1"> <tr> <td>1</td> <td>Enabled</td> </tr> <tr> <td>0</td> <td>Masked</td> </tr> </table>	1	Enabled	0	Masked
1	Enabled					
0	Masked					
09	RW	ADMA Error Signal Enable <table border="1"> <tr> <td>1</td> <td>Enabled</td> </tr> <tr> <td>0</td> <td>Masked</td> </tr> </table>	1	Enabled	0	Masked
1	Enabled					
0	Masked					
08	RW	Auto CMD Error Signal Enable <table border="1"> <tr> <td>1</td> <td>Enabled</td> </tr> <tr> <td>0</td> <td>Masked</td> </tr> </table>	1	Enabled	0	Masked
1	Enabled					
0	Masked					
07	RW	Current Limit Error Signal Enable <table border="1"> <tr> <td>1</td> <td>Enabled</td> </tr> <tr> <td>0</td> <td>Masked</td> </tr> </table>	1	Enabled	0	Masked
1	Enabled					
0	Masked					
06	RW	Data End Bit Error Signal Enable <table border="1"> <tr> <td>1</td> <td>Enabled</td> </tr> <tr> <td>0</td> <td>Masked</td> </tr> </table>	1	Enabled	0	Masked
1	Enabled					
0	Masked					
05	RW	Data CRC Error Signal Enable <table border="1"> <tr> <td>1</td> <td>Enabled</td> </tr> <tr> <td>0</td> <td>Masked</td> </tr> </table>	1	Enabled	0	Masked
1	Enabled					
0	Masked					
04	RW	Data Timeout Error Signal Enable <table border="1"> <tr> <td>1</td> <td>Enabled</td> </tr> <tr> <td>0</td> <td>Masked</td> </tr> </table>	1	Enabled	0	Masked
1	Enabled					
0	Masked					

SD Host Controller Simplified Specification Version 3.00

03	RW	Command Index Error Signal Enable				
		<table border="1"> <tr> <td>1</td> <td>Enabled</td> </tr> <tr> <td>0</td> <td>Masked</td> </tr> </table>	1	Enabled	0	Masked
1	Enabled					
0	Masked					
02	RW	Command End Bit Error Signal Enable				
		<table border="1"> <tr> <td>1</td> <td>Enabled</td> </tr> <tr> <td>0</td> <td>Masked</td> </tr> </table>	1	Enabled	0	Masked
1	Enabled					
0	Masked					
01	RW	Command CRC Error Signal Enable				
		<table border="1"> <tr> <td>1</td> <td>Enabled</td> </tr> <tr> <td>0</td> <td>Masked</td> </tr> </table>	1	Enabled	0	Masked
1	Enabled					
0	Masked					
00	RW	Command Timeout Error Signal Enable				
		<table border="1"> <tr> <td>1</td> <td>Enabled</td> </tr> <tr> <td>0</td> <td>Masked</td> </tr> </table>	1	Enabled	0	Masked
1	Enabled					
0	Masked					

Table 2-29 : Error Interrupt Signal Enable Register

2.2.23 Auto CMD Error Status Register (Offset 03Ch)

This register is used to indicate CMD12 response error of Auto CMD12 and CMD23 response error of Auto CMD23. The Host driver can determine what kind of Auto CMD12 / CMD23 errors occur by this register. Auto CMD23 errors are indicated in bit 04-01. This register is valid only when the **Auto CMD Error** is set.

D15	D08	D07	D06	D05	D04	D03	D02	D01	D00
Rsvd		Command Not Issued by Auto CMD12 Error	Rsvd		Auto CMD Index Error	Auto CMD End Bit Error	Auto CMD CRC Error	Auto CMD Timeout Error	Auto CMD12 not executed

Figure 2-27 : Auto CMD Error Status Register

Location	Attrib	Register Field Explanation				
15-08	Rsvd	Reserved				
07	ROC	<p>Command Not Issued By Auto CMD12 Error Setting this bit to 1 means CMD_wo_DAT is not executed due to an Auto CMD12 Error (D04-D01) in this register. This bit is set to 0 when Auto CMD Error is generated by Auto CMD23.</p> <table border="1"> <tr> <td>1</td> <td>Not Issued</td> </tr> <tr> <td>0</td> <td>No error</td> </tr> </table>	1	Not Issued	0	No error
1	Not Issued					
0	No error					
06-05	Rsvd	Reserved				
04	ROC	<p>Auto CMD Index Error This bit is set if the Command Index error occurs in response to a command.</p> <table border="1"> <tr> <td>1</td> <td>Error</td> </tr> <tr> <td>0</td> <td>No error</td> </tr> </table>	1	Error	0	No error
1	Error					
0	No error					
03	ROC	<p>Auto CMD End Bit Error This bit is set when detecting that the end bit of command response is 0.</p> <table border="1"> <tr> <td>1</td> <td>End Bit Error Generated</td> </tr> <tr> <td>0</td> <td>No error</td> </tr> </table>	1	End Bit Error Generated	0	No error
1	End Bit Error Generated					
0	No error					
02	ROC	<p>Auto CMD CRC Error This bit is set when detecting a CRC error in the command response.</p> <table border="1"> <tr> <td>1</td> <td>CRC Error Generated</td> </tr> <tr> <td>0</td> <td>No error</td> </tr> </table>	1	CRC Error Generated	0	No error
1	CRC Error Generated					
0	No error					
01	ROC	<p>Auto CMD Timeout Error This bit is set if no response is returned within 64 SDCLK cycles from the end bit of command. If this bit is set to 1, the other error status bits (D04-D02) are meaningless.</p> <table border="1"> <tr> <td>1</td> <td>Time out</td> </tr> <tr> <td>0</td> <td>No error</td> </tr> </table>	1	Time out	0	No error
1	Time out					
0	No error					

00	ROC	<p>Auto CMD12 Not Executed</p> <p>If memory multiple block data transfer is not started due to command error, this bit is not set because it is not necessary to issue Auto CMD12. Setting this bit to 1 means the Host Controller cannot issue Auto CMD12 to stop memory multiple block data transfer due to some error. If this bit is set to 1, other error status bits (D04-D01) are meaningless.</p> <p>This bit is set to 0 when Auto CMD Error is generated by Auto CMD23.</p> <table border="1"> <tr> <td>1</td> <td>Not executed</td> </tr> <tr> <td>0</td> <td>Executed</td> </tr> </table>	1	Not executed	0	Executed
1	Not executed					
0	Executed					

Table 2-30 : Auto CMD Error Status Register

The relation between Auto CMD CRC Error and Auto CMD Timeout Error is shown in Table 2-31 .:

Auto CMD CRC Error	Auto CMD Timeout Error	Kinds of error
0	0	No Error
0	1	Response Timeout Error
1	0	Response CRC Error
1	1	CMD line conflict

Table 2-31 : The Relation between CRC Error and Timeout Error for Auto CMD

The timing of changing *Auto CMD Error Status* can be classified in three scenarios:

- (1) When the Host Controller is going to issue Auto CMD12
Set D00 to 1 if Auto CMD12 cannot be issued due to an error in the previous command.
Set D00 to 0 if Auto CMD12 is issued.
- (2) At the end bit of an Auto CMD12 response
Check received responses by checking the error bits D01, D02, D03 and D04.
Set to 1 if error is detected.
Set to 0 if error is not detected.
- (3) Before reading the Auto CMD Error Status bit D07
Set D07 to 1 if there is a command cannot be issued
Set D07 to 0 if there is no command to issue

Timing of generating the **Auto CMD Error** and writing to the *Command* register are asynchronous. Then D07 shall be sampled when driver never writing to the *Command* register. So just before reading the *Auto CMD Error Status* register is good timing to set the D07 status bit.

An **Auto CMD Error** Interrupt is generated when one of the error bits D00 to D04 is set to 1. The **Command Not Issued By Auto CMD12 Error** does not make any effect on interrupt because it is set when one of bits D01 to D04 is set to 1.

2.2.24 Host Control 2 Register (Offset 03Eh)

D15	D14	D13	D08	D07	D06	D05-04	D03	D02- D00	
Preset Value Enable	Asynchronous Interrupt Enable	Reserved			Sampling Clock Select	Execute Tuning	Driver Strength Select	1.8V Signaling Enable	UHS Mode Select

Figure 2-28 : Host Control 2 Register

Location	Attrib	Register Field Explanation				
15	RW	<p>Preset Value Enable Host Controller Version 3.00 supports this bit. As the operating SDCLK frequency and I/O driver strength depend on the Host System implementation, it is difficult to determine these parameters in the Standard Host Driver. When Preset Value Enable is set, automatic SDCLK frequency generation and driver strength selection is performed without considering system specific conditions. This bit enables the functions defined in the <i>Preset Value</i> registers.</p> <table border="1"> <tr> <td>1</td> <td>Automatic Selection by Preset Value are Enabled</td> </tr> <tr> <td>0</td> <td>SDCLK and Driver Strength are controlled by Host Driver</td> </tr> </table> <p>If this bit is set to 0, SDCLK Frequency Select, Clock Generator Select in the <i>Clock Control</i> register and Driver Strength Select in <i>Host Control 2</i> register are set by Host Driver. If this bit is set to 1, SDCLK Frequency Select, Clock Generator Select in the <i>Clock Control</i> register and Driver Strength Select in <i>Host Control 2</i> register are set by Host Controller as specified in the <i>Preset Value</i> registers.</p>	1	Automatic Selection by Preset Value are Enabled	0	SDCLK and Driver Strength are controlled by Host Driver
1	Automatic Selection by Preset Value are Enabled					
0	SDCLK and Driver Strength are controlled by Host Driver					
14	RW	<p>Asynchronous Interrupt Enable This bit can be set to 1 if a card supports asynchronous interrupts and Asynchronous Interrupt Support is set to 1 in the <i>Capabilities</i> register. Asynchronous interrupt is effective when DAT[1] interrupt is used in 4-bit SD mode (and zero is set to Interrupt Pin Select in the <i>Shared Bus Control</i> register). If this bit is set to 1, the Host Driver can stop the SDCLK during asynchronous interrupt period to save power. During this period, the Host Controller continues to deliver the Card Interrupt to the host when it is asserted by the Card.</p> <table border="1"> <tr> <td>1</td> <td>Enabled</td> </tr> <tr> <td>0</td> <td>Disabled</td> </tr> </table>	1	Enabled	0	Disabled
1	Enabled					
0	Disabled					
13-08	Rsvd	Reserved				

SD Host Controller Simplified Specification Version 3.00

07	RW	<p>Sampling Clock Select Host Controller uses this bit to select sampling clock to receive CMD and DAT. This bit is set by tuning procedure and valid after the completion of tuning (when Execute Tuning is cleared). Setting 1 means that tuning is completed successfully and setting 0 means that tuning is failed. Writing 1 to this bit is meaningless and ignored. A tuning circuit is reset by writing to 0. This bit can be cleared with setting Execute Tuning. Once the tuning circuit is reset, it will take time to complete tuning sequence. Therefore, Host Driver should keep this bit to 1 to perform re-tuning sequence to complete re-tuning sequence in a short time. Change of this bit is not allowed while the Host Controller is receiving response or a read data block. Refer to Figure 2-29.</p> <table border="1" data-bbox="524 573 1182 638"> <tr> <td>1</td> <td>Tuned clock is used to sample data</td> </tr> <tr> <td>0</td> <td>Fixed clock is used to sample data</td> </tr> </table>	1	Tuned clock is used to sample data	0	Fixed clock is used to sample data				
1	Tuned clock is used to sample data									
0	Fixed clock is used to sample data									
06	RWAC	<p>Execute Tuning This bit is set to 1 to start tuning procedure and automatically cleared when tuning procedure is completed. The result of tuning is indicated to Sampling Clock Select. Tuning procedure is aborted by writing 0. Refer to Figure 2-29 for more detail about tuning procedure.</p> <table border="1" data-bbox="524 831 1182 898"> <tr> <td>1</td> <td>Execute Tuning</td> </tr> <tr> <td>0</td> <td>Not Tuned or Tuning Completed</td> </tr> </table>	1	Execute Tuning	0	Not Tuned or Tuning Completed				
1	Execute Tuning									
0	Not Tuned or Tuning Completed									
05-04	RW	<p>Driver Strength Select Host Controller output driver in 1.8V signaling is selected by this bit. In 3.3V signaling, this field is not effective. This field can be set depends on Driver Type A, C and D support bits in the <i>Capabilities</i> register.</p> <p>This bit depends on setting of Preset Value Enable. If Preset Value Enable = 0, this field is set by Host Driver. If Preset Value Enable = 1, this field is automatically set by a value specified in the one of <i>Preset Value</i> registers.</p> <table border="1" data-bbox="524 1220 1182 1348"> <tr> <td>00b</td> <td>Driver Type B is Selected (Default)</td> </tr> <tr> <td>01b</td> <td>Driver Type A is Selected</td> </tr> <tr> <td>10b</td> <td>Driver Type C is Selected</td> </tr> <tr> <td>11b</td> <td>Driver Type D is Selected</td> </tr> </table>	00b	Driver Type B is Selected (Default)	01b	Driver Type A is Selected	10b	Driver Type C is Selected	11b	Driver Type D is Selected
00b	Driver Type B is Selected (Default)									
01b	Driver Type A is Selected									
10b	Driver Type C is Selected									
11b	Driver Type D is Selected									

SD Host Controller Simplified Specification Version 3.00

03	RW	<p>1.8V Signaling Enable</p> <p>This bit controls voltage regulator for I/O cell. 3.3V is supplied to the card regardless of signaling voltage.</p> <p>Setting this bit from 0 to 1 starts changing signal voltage from 3.3V to 1.8V. 1.8V regulator output shall be stable within 5ms. Host Controller clears this bit if switching to 1.8V signaling fails.</p> <p>Clearing this bit from 1 to 0 starts changing signal voltage from 1.8V to 3.3V. 3.3V regulator output shall be stable within 5ms.</p> <p>Host Driver can set this bit to 1 when Host Controller supports 1.8V signaling (One of support bits is set to 1: SDR50, SDR104 or DDR50 in the Capabilities register) and the card or device supports UHS-I (S18A=1. Refer to Bus Signal Voltage Switch Sequence in the Physical Layer Specification Version 3.0x).</p> <table border="1" data-bbox="524 667 881 730"> <tr> <td>1</td> <td>1.8V Signaling</td> </tr> <tr> <td>0</td> <td>3.3V Signaling</td> </tr> </table>	1	1.8V Signaling	0	3.3V Signaling												
1	1.8V Signaling																	
0	3.3V Signaling																	
02-00	RW	<p>UHS Mode Select</p> <p>This field is used to select one of UHS-I modes and effective when 1.8V Signaling Enable is set to 1.</p> <p>If Preset Value Enable in the <i>Host Control 2</i> register is set to 1, Host Controller sets SDCLK Frequency Select, Clock Generator Select in the <i>Clock Control</i> register and Driver Strength Select according to <i>Preset Value</i> registers. In this case, one of preset value registers is selected by this field. Host Driver needs to reset SD Clock Enable before changing this field to avoid generating clock glitch. After setting this field, Host Driver sets SD Clock Enable again.</p> <table border="1" data-bbox="524 1119 881 1381"> <tr> <td>000b</td> <td>SDR12</td> </tr> <tr> <td>001b</td> <td>SDR25</td> </tr> <tr> <td>010b</td> <td>SDR50</td> </tr> <tr> <td>011b</td> <td>SDR104</td> </tr> <tr> <td>100b</td> <td>DDR50</td> </tr> <tr> <td>101b</td> <td>Reserved</td> </tr> <tr> <td>110b</td> <td>Reserved</td> </tr> <tr> <td>111b</td> <td>Reserved</td> </tr> </table> <p>When SDR50, SDR104 or DDR50 is selected for SDIO card, interrupt detection at the block gap shall not be used. Read Wait timing is changed for these modes. Refer to the SDIO Specification Version 3.00 for more detail.</p>	000b	SDR12	001b	SDR25	010b	SDR50	011b	SDR104	100b	DDR50	101b	Reserved	110b	Reserved	111b	Reserved
000b	SDR12																	
001b	SDR25																	
010b	SDR50																	
011b	SDR104																	
100b	DDR50																	
101b	Reserved																	
110b	Reserved																	
111b	Reserved																	

Table 2-32 : Host Control 2 Register

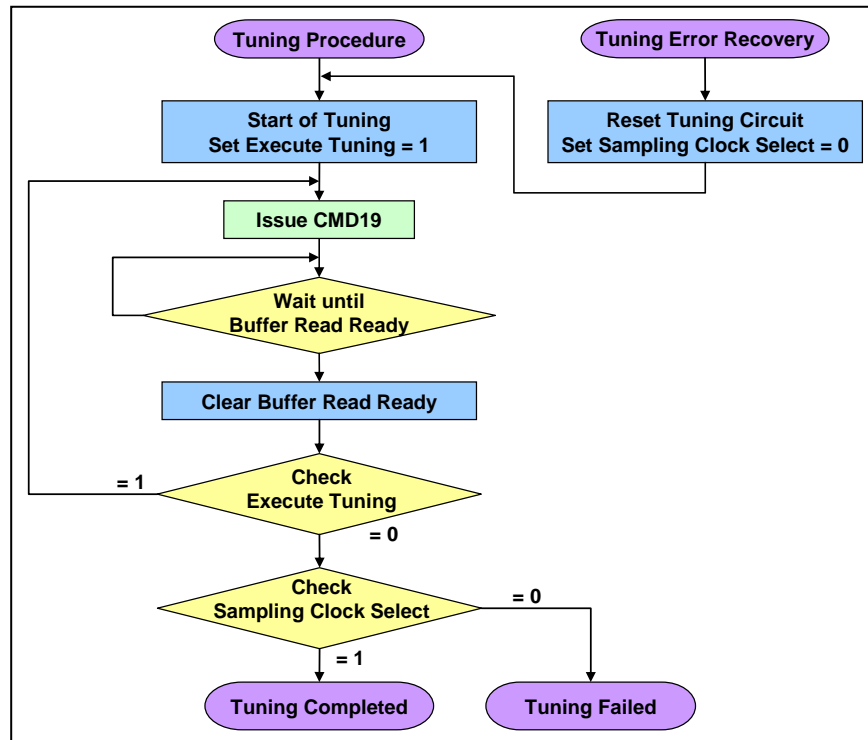

Figure 2-29 : Sampling Clock Tuning Procedure

Figure 2-29 shows the tuning procedure to adjust the sampling clock. In the default, lower frequency operation, a fixed sampling clock is used to receive signals on **CMD** and **DAT[3:0]**. Before using the SDR104 or SDR50 (if **Use Tuning for SDR50** is set to 1 in the *Capabilities* register) modes, the Host Driver shall execute the tuning procedure at the initialization sequence regardless of **Re-Tuning Modes** state in the *Capabilities* register.

The Host Driver requests the Host Controller to start the tuning sequence by setting **Execute Tuning** to 1. The Host Driver issues CMD19 repeatedly until the host controller resets **Execute Tuning** to 0. The Host Controller then resets **Execute Tuning** when the tuning is completed or the tuning is not completed within 40 tries. The Host Driver may abort this loop by the number of loops is reached to 40 times or 150ms timeout occurs. In this case, a fixed sampling clock should be used (Sampling Clock Select = 0).

The **Sampling Clock Select** is valid after **Execute Tuning** has changed from 1 to 0. Setting **Sampling Clock Select** to 1 indicates that the tuning procedure has completed successfully. Setting **Sampling Clock Select** to 0 indicates that the tuning procedure has failed.

While the tuning sequence is being performed, the Host Controller does not generate interrupts (including **Command Complete**) except **Buffer Read Ready** and CMD19 response errors are not indicated.

Writing **Sampling Clock Select** to 0 forces the Host Controller to use a fixed sampling clock and resets the tuning circuit of the Host Controller. If tuning is started after the reset of tuning circuit, it will take time to complete tuning sequence. Therefore, re-tuning should be started while keeping **Sampling Clock Select** to 1 so that the re-tuning time will be shorter than the first tuning time.

When receiving **Tuning Error** interrupt, the Host Driver needs to reset the tuning circuit by clearing the **Sampling Clock Select** to 0 and then execute the tuning procedure.

The re-tuning timing is specified by two methods: **Re-Tuning Request** generated by Host Controller and expiration of a re-tuning timer prepared by Host Driver. When Host Driver receives either interrupts, the tuning procedure defined by Figure 2-29 is inserted before issuing any command. Refer to **Re-Tuning Request** in the *Present State* register and **Re-Tuning Modes** in the *Capabilities* register for more detail.

SD Host Controller Simplified Specification Version 3.00**2.2.25 Capabilities Register (Offset 040h)**

This register provides the Host Driver with information specific to the Host Controller implementation. The Host Controller may implement these values as fixed or loaded from flash memory during power on initialization. Refer to **Software Reset For All** in the *Software Reset* register for loading from flash memory and completion timing control.

D63 D56	D55	D48	D47	D46	D45	D44	D43-D40	D39	D38	D37	D36	D35	D34	D33	D32
Rsvd	Clock Multiplier	Re-Tuning Modes	Use Tuning for SDR50	Rsvd	Timer Count for Re-Tuning	Rsvd	Driver Type D Support	Driver Type C Support	Driver Type A Support	Rsvd	DDR50 Support	SDR104 Support	SDR50 Support		

D31	D30	D29	D28	D27	D26	D25	D24	D23	D22	D21	D20	D19	D18	D17-16	D15-D08	D07	D06	D05-D00
Slot Type	Asynchronous Interrupt Support	64-bit System Bus Support	Rsvd	Voltage Support 1.8V	Voltage Support 3.0V	Voltage Support 3.3V	Suspend/Resume Support	SDMA Support	High Speed Support	Rsvd	ADMA2 Support	8-bit Support for Embedded Device	Max Block Length	Base Clock Frequency For SD Clock	Timeout Clock Unit	Rsvd	Timeout Clock Frequency	

Figure 2-30 : Capabilities Register

Location	Attrib	Register Field Explanation																				
63-56	Rsvd	Reserved																				
55-48	Hwlnit	<p>Clock Multiplier This field indicates clock multiplier value of programmable clock generator. Refer to <i>Clock Control</i> register. Setting 00h means that Host Controller does not support programmable clock generator.</p> <table border="1"> <tr> <td>00h</td> <td>Clock Multiplier is Not Supported</td> </tr> <tr> <td>01h</td> <td>Clock Multiplier M = 2</td> </tr> <tr> <td>02h</td> <td>Clock Multiplier M = 3</td> </tr> <tr> <td>.....</td> <td>.....</td> </tr> <tr> <td>FFh</td> <td>Clock Multiplier M = 256</td> </tr> </table>	00h	Clock Multiplier is Not Supported	01h	Clock Multiplier M = 2	02h	Clock Multiplier M = 3	FFh	Clock Multiplier M = 256										
00h	Clock Multiplier is Not Supported																					
01h	Clock Multiplier M = 2																					
02h	Clock Multiplier M = 3																					
.....																					
FFh	Clock Multiplier M = 256																					
47-46	Hwlnit	<p>Re-Tuning Modes This field selects re-tuning method and limits the maximum data length.</p> <table border="1"> <thead> <tr> <th>Bit47-46</th> <th>Re-Tuning Mode</th> <th>Re-Tuning Method</th> <th>Data Length</th> </tr> </thead> <tbody> <tr> <td>00b</td> <td>Mode 1</td> <td>Timer</td> <td>4MB (Max.)</td> </tr> <tr> <td>01b</td> <td>Mode 2</td> <td>Timer and Re-Tuning Request</td> <td>4MB (Max.)</td> </tr> <tr> <td>10b</td> <td>Mode 3</td> <td>Auto Re-Tuning (for transfer) Timer and Re-Tuning Request</td> <td>Any</td> </tr> <tr> <td>11b</td> <td colspan="3">Reserved</td> </tr> </tbody> </table> <p>There are two re-tuning timings: Re-Tuning Request controlled by the Host Controller and expiration of a Re-Tuning Timer controlled by the Host</p>	Bit47-46	Re-Tuning Mode	Re-Tuning Method	Data Length	00b	Mode 1	Timer	4MB (Max.)	01b	Mode 2	Timer and Re-Tuning Request	4MB (Max.)	10b	Mode 3	Auto Re-Tuning (for transfer) Timer and Re-Tuning Request	Any	11b	Reserved		
Bit47-46	Re-Tuning Mode	Re-Tuning Method	Data Length																			
00b	Mode 1	Timer	4MB (Max.)																			
01b	Mode 2	Timer and Re-Tuning Request	4MB (Max.)																			
10b	Mode 3	Auto Re-Tuning (for transfer) Timer and Re-Tuning Request	Any																			
11b	Reserved																					

	<p>Driver. By receiving either timing, the Host Driver executes the re-tuning procedure just before a next command issue.</p> <p>The maximum data length per read/write command is restricted so that re-tuning procedures can be inserted during data transfers.</p> <p>(1) Re-Tuning Mode 1 The host controller does not have any internal logic to detect when the re-tuning needs to be performed. In this case, the Host Driver should maintain all re-tuning timings by using a Re-Tuning Timer. To enable inserting the re-tuning procedure during data transfers, the data length per read/write command shall be limited up to 4MB.</p> <p>(2) Re-Tuning Mode 2 The host controller has the capability to indicate the re-tuning timing by Re-Tuning Request during data transfers. Then the data length per read/write command shall be limited up to 4MB. During non data transfer, re-tuning timing is determined by either Re-Tuning Request or Re-Tuning Timer. If Re-Tuning Request is used, Re-Tuning Timer should be disabled.</p> <p>(3) Re-Tuning Mode 3 The host controller has the capability to take care of the re-tuning during data transfer (Auto Re-Tuning). Re-Tuning Request shall not be generated during data transfers and there is no limitation to data length per read/write command. During non data transfer, re-tuning timing is determined by either Re-Tuning Request or Re-Tuning Timer. If Re-Tuning Request is used, Re-Tuning Timer should be disabled.</p> <p>Re-Tuning Timer Control Example for Re-Tuning Mode 1 The initial value of re-tuning timer is provided by Timer Count for Re-Tuning field in this register. The timer starts counting by loading the initial value. When the timer expires, the Host Driver marks an expiration flag. On receiving a command request, the Host driver checks the expiration flag. If the expiration flag is set, then the Host Driver should perform the re-tuning procedure before issuing a command. If the expiration flag is not set, then the Host Driver issues a command without performing the re-tuning procedure. Every time the re-tuning procedure is performed, the timer loads the new initial value and the expiration flag is cleared.</p> <p>Re-Tuning Timer Control Example for Re-Tuning Mode 2 and Mode 3 The timer control is almost the same as Re-Tuning Mode 1 except the timer loads the new initial value after data transfer (when receiving Transfer Complete). In case of Mode 3, Timer Count for Re-Tuning is set either smaller value: Tuning effective time after re-tuning procedure or after data transfer.</p> <p>If a Host System goes into power down mode, the Host Driver should stop the re-tuning timer and set the expiration flag to 1 when the Host System resumes from power down mode.</p>
--	---

SD Host Controller Simplified Specification Version 3.00

45	Hwlnit	<p>Use Tuning for SDR50 If this bit is set to 1, this Host Controller requires tuning to operate SDR50. (Tuning is always required to operate SDR104.)</p> <table border="1"> <tr> <td>1</td> <td>SDR50 requires tuning</td> </tr> <tr> <td>0</td> <td>SDR50 does not require tuning</td> </tr> </table>	1	SDR50 requires tuning	0	SDR50 does not require tuning																		
1	SDR50 requires tuning																							
0	SDR50 does not require tuning																							
44	Rsvd	Reserved																						
43-40	Hwlnit	<p>Timer Count for Re-Tuning This field indicates an initial value of the Re-Tuning Timer for Re-Tuning Mode 1 to 3. Setting to 0 disables Re-Tuning Timer.</p> <table border="1"> <tr> <td>0h</td> <td>Re-Tuning Timer disabled</td> </tr> <tr> <td>1h</td> <td>1 seconds</td> </tr> <tr> <td>2h</td> <td>2 seconds</td> </tr> <tr> <td>3h</td> <td>4 seconds</td> </tr> <tr> <td>4h</td> <td>8 seconds</td> </tr> <tr> <td>.....</td> <td>.....</td> </tr> <tr> <td>n</td> <td>$2^{(n-1)}$ seconds</td> </tr> <tr> <td>.....</td> <td>.....</td> </tr> <tr> <td>Bh</td> <td>1024 seconds</td> </tr> <tr> <td>Eh - Ch</td> <td>Reserved</td> </tr> <tr> <td>Fh</td> <td>Get information from other source</td> </tr> </table>	0h	Re-Tuning Timer disabled	1h	1 seconds	2h	2 seconds	3h	4 seconds	4h	8 seconds	n	$2^{(n-1)}$ seconds	Bh	1024 seconds	Eh - Ch	Reserved	Fh	Get information from other source
0h	Re-Tuning Timer disabled																							
1h	1 seconds																							
2h	2 seconds																							
3h	4 seconds																							
4h	8 seconds																							
.....																							
n	$2^{(n-1)}$ seconds																							
.....																							
Bh	1024 seconds																							
Eh - Ch	Reserved																							
Fh	Get information from other source																							
39	Rsvd	Reserved																						
38	Hwlnit	<p>Driver Type D Support This bit indicates support of Driver Type D for 1.8 Signaling.</p> <table border="1"> <tr> <td>1</td> <td>Driver Type D is Supported</td> </tr> <tr> <td>0</td> <td>Driver Type D is Not Supported</td> </tr> </table>	1	Driver Type D is Supported	0	Driver Type D is Not Supported																		
1	Driver Type D is Supported																							
0	Driver Type D is Not Supported																							
37	Hwlnit	<p>Driver Type C Support This bit indicates support of Driver Type C for 1.8 Signaling.</p> <table border="1"> <tr> <td>1</td> <td>Driver Type C is Supported</td> </tr> <tr> <td>0</td> <td>Driver Type C is Not Supported</td> </tr> </table>	1	Driver Type C is Supported	0	Driver Type C is Not Supported																		
1	Driver Type C is Supported																							
0	Driver Type C is Not Supported																							
36	Hwlnit	<p>Driver Type A Support This bit indicates support of Driver Type A for 1.8 Signaling.</p> <table border="1"> <tr> <td>1</td> <td>Driver Type A is Supported</td> </tr> <tr> <td>0</td> <td>Driver Type A is Not Supported</td> </tr> </table>	1	Driver Type A is Supported	0	Driver Type A is Not Supported																		
1	Driver Type A is Supported																							
0	Driver Type A is Not Supported																							
35	Rsvd	Reserved																						
34	Hwlnit	<p>DDR50 Support</p> <table border="1"> <tr> <td>1</td> <td>DDR50 is Supported</td> </tr> <tr> <td>0</td> <td>DDR50 is Not Supported</td> </tr> </table>	1	DDR50 is Supported	0	DDR50 is Not Supported																		
1	DDR50 is Supported																							
0	DDR50 is Not Supported																							
33	Hwlnit	<p>SDR104 Support SDR104 requires tuning.</p> <table border="1"> <tr> <td>1</td> <td>SDR104 is Supported</td> </tr> <tr> <td>0</td> <td>SDR104 is Not Supported</td> </tr> </table>	1	SDR104 is Supported	0	SDR104 is Not Supported																		
1	SDR104 is Supported																							
0	SDR104 is Not Supported																							

SD Host Controller Simplified Specification Version 3.00

32	Hwlnit	<p>SDR50 Support If SDR104 is supported, this bit shall be set to 1. Bit 45 indicates whether SDR50 requires tuning or not.</p> <table border="1"> <tr> <td>1</td> <td>SDR50 is Supported</td> </tr> <tr> <td>0</td> <td>SDR50 is Not Supported</td> </tr> </table>	1	SDR50 is Supported	0	SDR50 is Not Supported				
1	SDR50 is Supported									
0	SDR50 is Not Supported									
31-30	Hwlnit	<p>Slot Type This field indicates usage of a slot by a specific Host System. (A host controller register set is defined per slot.) Embedded Slot for One Device (01b) means that only one non-removable device is connected to a SD bus slot. Shared Bus Slot (10b) can be set if Host Controller supports <i>Shared Bus Control</i> register.</p> <p>The Standard Host Driver controls only a removable card or one embedded device connected to a SD bus slot. If a slot is configured for shared bus (10b), the Standard Host Driver does not control embedded devices connected to a shared bus. Shared bus slot is controlled by a specific host driver developed by a Host System.</p> <table border="1"> <tr> <td>00b</td> <td>Removable Card Slot</td> </tr> <tr> <td>01b</td> <td>Embedded Slot for One Device</td> </tr> <tr> <td>10b</td> <td>Shared Bus Slot</td> </tr> <tr> <td>11b</td> <td>Reserved</td> </tr> </table>	00b	Removable Card Slot	01b	Embedded Slot for One Device	10b	Shared Bus Slot	11b	Reserved
00b	Removable Card Slot									
01b	Embedded Slot for One Device									
10b	Shared Bus Slot									
11b	Reserved									
29	Hwlnit	<p>Asynchronous Interrupt Support Refer to SDIO Specification Version 3.00 about asynchronous interrupt.</p> <table border="1"> <tr> <td>1</td> <td>Asynchronous Interrupt Supported</td> </tr> <tr> <td>0</td> <td>Asynchronous Interrupt Not Supported</td> </tr> </table>	1	Asynchronous Interrupt Supported	0	Asynchronous Interrupt Not Supported				
1	Asynchronous Interrupt Supported									
0	Asynchronous Interrupt Not Supported									
28	Hwlnit	<p>64-bit System Bus Support Setting 1 to this bit indicates that the Host Controller supports 64-bit address descriptor mode and is connected to 64-bit address system bus.</p>								
27	Rsvd	<p>Reserved Reserved for voltage support</p>								
26	Hwlnit	<p>Voltage Support 1.8V Embedded system can use 1.8V power supply.</p> <table border="1"> <tr> <td>1</td> <td>1.8V Supported</td> </tr> <tr> <td>0</td> <td>1.8V Not Supported</td> </tr> </table>	1	1.8V Supported	0	1.8V Not Supported				
1	1.8V Supported									
0	1.8V Not Supported									
25	Hwlnit	<p>Voltage Support 3.0V</p> <table border="1"> <tr> <td>1</td> <td>3.0V Supported</td> </tr> <tr> <td>0</td> <td>3.0V Not Supported</td> </tr> </table>	1	3.0V Supported	0	3.0V Not Supported				
1	3.0V Supported									
0	3.0V Not Supported									
24	Hwlnit	<p>Voltage Support 3.3V</p> <table border="1"> <tr> <td>1</td> <td>3.3V Supported</td> </tr> <tr> <td>0</td> <td>3.3V Not Supported</td> </tr> </table>	1	3.3V Supported	0	3.3V Not Supported				
1	3.3V Supported									
0	3.3V Not Supported									

Table 2-33 : Capabilities Register (Part 1)

If a slot is for removable card (Slot Type = 00b), Host System can set Voltage Support 3.3V or 3.0V. Host Driver selects 3.3V in default. If 3.3V is not supported, 3.0V is selected.

If a slot is for embedded device (Slot Type = 01b or 11b), Host System can set one of Voltage Support bits for host interface voltage (VDDH).

SD Host Controller Simplified Specification Version 3.00

Location	Attrib	Register Field Explanation								
23	Hwlnit	<p>Suspend/Resume Support This bit indicates whether the Host Controller supports Suspend / Resume functionality. If this bit is 0, the Host Driver shall not issue either Suspend or Resume commands because the Suspend and Resume mechanism (Refer to Section 1.6) is not supported.</p> <table border="1"> <tr> <td>1</td> <td>Supported</td> </tr> <tr> <td>0</td> <td>Not Supported</td> </tr> </table>	1	Supported	0	Not Supported				
1	Supported									
0	Not Supported									
22	Hwlnit	<p>SDMA Support This bit indicates whether the Host Controller is capable of using SDMA to transfer data between system memory and the Host Controller directly.</p> <table border="1"> <tr> <td>1</td> <td>SDMA Supported</td> </tr> <tr> <td>0</td> <td>SDMA not Supported</td> </tr> </table>	1	SDMA Supported	0	SDMA not Supported				
1	SDMA Supported									
0	SDMA not Supported									
21	Hwlnit	<p>High Speed Support This bit indicates whether the Host Controller and the Host System support High Speed mode and they can supply SD Clock frequency from 25MHz to 50MHz.</p> <table border="1"> <tr> <td>1</td> <td>High Speed Supported</td> </tr> <tr> <td>0</td> <td>High Speed not Supported</td> </tr> </table>	1	High Speed Supported	0	High Speed not Supported				
1	High Speed Supported									
0	High Speed not Supported									
20	Hwlnit	<p>Reserved (New assignment is not allowed) This bit is reserved for backward compatibility with prior specifications. If set, the Host Controller is indicating that it supports legacy ADMA1 mode. Host drivers are not required to support this mode.</p>								
19	Hwlnit	<p>ADMA2 Support This bit indicates whether the Host Controller is capable of using ADMA2.</p> <table border="1"> <tr> <td>1</td> <td>ADMA2 Supported</td> </tr> <tr> <td>0</td> <td>ADMA2 not Supported</td> </tr> </table>	1	ADMA2 Supported	0	ADMA2 not Supported				
1	ADMA2 Supported									
0	ADMA2 not Supported									
18	Hwlnit	<p>8-bit Support for Embedded Device This bit indicates whether the Host Controller is capable of using 8-bit bus width mode. This bit is not effective when Slot Type is set to 10b. In this case, refer to Bus Width Preset in the <i>Shared Bus</i> register.</p> <table border="1"> <tr> <td>1</td> <td>8-bit Bus Width Supported</td> </tr> <tr> <td>0</td> <td>8-bit Bus Width not Supported</td> </tr> </table>	1	8-bit Bus Width Supported	0	8-bit Bus Width not Supported				
1	8-bit Bus Width Supported									
0	8-bit Bus Width not Supported									
17-16	Hwlnit	<p>Max Block Length This value indicates the maximum block size that the Host Driver can read and write to the buffer in the Host Controller. The buffer shall transfer this block size without wait cycles. Three sizes can be defined as indicated below. It is noted that transfer block length shall be always 512 bytes for SD Memory Cards regardless this field.</p> <table border="1"> <tr> <td>00</td> <td>512(byte)</td> </tr> <tr> <td>01</td> <td>1024</td> </tr> <tr> <td>10</td> <td>2048</td> </tr> <tr> <td>11</td> <td>Reserved</td> </tr> </table>	00	512(byte)	01	1024	10	2048	11	Reserved
00	512(byte)									
01	1024									
10	2048									
11	Reserved									

SD Host Controller Simplified Specification Version 3.00

15-08	Hwlnit	<p>Base Clock Frequency For SD Clock This value indicates the base (maximum) clock frequency for the SD Clock. Definition of this field depends on Host Controller Version.</p> <p>(1) 6-bit Base Clock Frequency This mode is supported by the Host Controller Version 1.00 and 2.00. Upper 2 bits are not effective and always 0. Unit values are 1MHz. The supported clock range is 10MHz to 63MHz.</p> <table border="1" data-bbox="506 478 1205 674"> <tr><td>11xx xxxxb</td><td>Not supported</td></tr> <tr><td>0011 1111b</td><td>63MHz</td></tr> <tr><td>.....</td><td>.....</td></tr> <tr><td>0000 0010b</td><td>2MHz</td></tr> <tr><td>0000 0001b</td><td>1MHz</td></tr> <tr><td>0000 0000b</td><td>Get information via another method</td></tr> </table> <p>(2) 8-bit Base Clock Frequency This mode is supported by the Host Controller Version 3.00. Unit values are 1MHz. The supported clock range is 10MHz to 255MHz.</p> <table border="1" data-bbox="506 835 1205 997"> <tr><td>FFh</td><td>255MHz</td></tr> <tr><td>.....</td><td>.....</td></tr> <tr><td>02h</td><td>2MHz</td></tr> <tr><td>01h</td><td>1MHz</td></tr> <tr><td>00h</td><td>Get information via another method</td></tr> </table> <p>If the real frequency is 16.5MHz, the larger value shall be set 0001 0001b (17MHz) because the Host Driver use this value to calculate the clock divider value (Refer to the SDCLK Frequency Select in the <i>Clock Control</i> register.) and it shall not exceed upper limit of the SD Clock frequency. If these bits are all 0, the Host System has to get information via another method.</p>	11xx xxxxb	Not supported	0011 1111b	63MHz	0000 0010b	2MHz	0000 0001b	1MHz	0000 0000b	Get information via another method	FFh	255MHz	02h	2MHz	01h	1MHz	00h	Get information via another method
11xx xxxxb	Not supported																							
0011 1111b	63MHz																							
.....																							
0000 0010b	2MHz																							
0000 0001b	1MHz																							
0000 0000b	Get information via another method																							
FFh	255MHz																							
.....																							
02h	2MHz																							
01h	1MHz																							
00h	Get information via another method																							
07	Hwlnit	<p>Timeout Clock Unit This bit shows the unit of base clock frequency used to detect Data Timeout Error.</p> <table border="1" data-bbox="506 1381 743 1451"> <tr><td>0</td><td>KHz</td></tr> <tr><td>1</td><td>MHz</td></tr> </table>	0	KHz	1	MHz																		
0	KHz																							
1	MHz																							
06	Rsvd	Reserved																						
05-00	Hwlnit	<p>Timeout Clock Frequency This bit shows the base clock frequency used to detect Data Timeout Error. The Timeout Clock Unit defines the unit of this field's value. Timeout Clock Unit =0 [KHz] unit: 1KHz to 63KHz Timeout Clock Unit =1 [MHz] unit: 1MHz to 63MHz</p> <table border="1" data-bbox="506 1675 1122 1736"> <tr><td>Not 0</td><td>1KHz to 63KHz or 1MHz to 63MHz</td></tr> <tr><td>00 0000b</td><td>Get information via another method</td></tr> </table>	Not 0	1KHz to 63KHz or 1MHz to 63MHz	00 0000b	Get information via another method																		
Not 0	1KHz to 63KHz or 1MHz to 63MHz																							
00 0000b	Get information via another method																							

Table 2-34 : Capabilities Register (Part 2)

2.2.26 Maximum Current Capabilities Register (Offset 048h)

These registers indicate maximum current capability for each voltage. The value is meaningful if **Voltage Support** is set in the *Capabilities* register. If this information is supplied by the Host System via another method, all *Maximum Current Capabilities* register shall be 0.

D63								D32																							
Rsvd																															
D31				D24				D23				D16				D15				D08				D07				D00			
Rsvd				Rsvd				Maximum Current for 1.8V				Maximum Current for 3.0V				Maximum Current for 3.3V															

Figure 2-31 : Maximum Current Capabilities Register

Location	Attrib	Register Field Explanation
63-56	Rsvd	Reserved
55-48	Rsvd	Reserved
47-40	Rsvd	Reserved
39-32	Rsvd	Reserved
31-24	Rsvd	Reserved
23-16	Hwlnit	Maximum Current for 1.8V
15-08	Hwlnit	Maximum Current for 3.0V
07-00	Hwlnit	Maximum Current for 3.3V

Table 2-35 : Maximum Current Capabilities Register

This register measures current in 4mA steps. Each voltage level's current support is described using the Table 2-36.

Register Value	Current Value
0	Get information via another method
1	4mA
2	8mA
3	12mA
.....
255	1020mA

Table 2-36 : Maximum Current Value Definition

SDXC card supported Host Driver needs to check this register to determine **XPC** value in the argument of ACMD41. If a Host System can afford more than 150mA, Host Driver set **XPC** to 1. If a Host System can afford less than 150mA, Host Driver set **XPC** to 0. Refer to the Physical Layer Specification Version 3.0x for more detail of **XPC**.

SD Host Controller Simplified Specification Version 3.00**2.2.27 Force Event Register for Auto CMD Error Status (Offset 050h)**

The *Force Event* Register is not a physically implemented register. Rather, it is an address at which the *Auto CMD Error Status* Register can be written.

Writing 1 : set each bit of the *Auto CMD Error Status* Register

Writing 0 : no effect

D15	D08	D07	D06	D05	D04	D03	D02	D01	D00
Rsvd		Force Event for Command Not Issued by Auto CMD12 Error	Rsvd		Force Event for Auto CMD Index Error	Force Event for Auto CMD End Bit Error	Force Event for Auto CMD CRC Error	Force Event for Auto CMD Timeout Error	Force Event for Auto CMD12 not executed

Figure 2-32 : Force Event Register for Auto CMD Error Status

Location	Attrib	Register Field Explanation				
15-08	Rsvd	Reserved				
07	WO	Force Event for Command Not Issued By Auto CMD12 Error <table border="1"> <tr> <td>1</td> <td>Interrupt is generated</td> </tr> <tr> <td>0</td> <td>No Interrupt</td> </tr> </table>	1	Interrupt is generated	0	No Interrupt
1	Interrupt is generated					
0	No Interrupt					
06-05	Rsvd	Reserved				
04	WO	Force Event for Auto CMD Index Error <table border="1"> <tr> <td>1</td> <td>Interrupt is generated</td> </tr> <tr> <td>0</td> <td>No Interrupt</td> </tr> </table>	1	Interrupt is generated	0	No Interrupt
1	Interrupt is generated					
0	No Interrupt					
03	WO	Force Event for Auto CMD End Bit Error <table border="1"> <tr> <td>1</td> <td>Interrupt is generated</td> </tr> <tr> <td>0</td> <td>No Interrupt</td> </tr> </table>	1	Interrupt is generated	0	No Interrupt
1	Interrupt is generated					
0	No Interrupt					
02	WO	Force Event for Auto CMD CRC Error <table border="1"> <tr> <td>1</td> <td>Interrupt is generated</td> </tr> <tr> <td>0</td> <td>No Interrupt</td> </tr> </table>	1	Interrupt is generated	0	No Interrupt
1	Interrupt is generated					
0	No Interrupt					
01	WO	Force Event for Auto CMD Timeout Error <table border="1"> <tr> <td>1</td> <td>Interrupt is generated</td> </tr> <tr> <td>0</td> <td>No Interrupt</td> </tr> </table>	1	Interrupt is generated	0	No Interrupt
1	Interrupt is generated					
0	No Interrupt					
00	WO	Force Event for Auto CMD12 Not Executed <table border="1"> <tr> <td>1</td> <td>Interrupt is generated</td> </tr> <tr> <td>0</td> <td>No Interrupt</td> </tr> </table>	1	Interrupt is generated	0	No Interrupt
1	Interrupt is generated					
0	No Interrupt					

Table 2-37 : Force Event Register for Auto CMD Error Status

SD Host Controller Simplified Specification Version 3.00**2.2.28 Force Event Register for Error Interrupt Status (Offset 052h)**

The *Force Event* Register is not a physically implemented register. Rather, it is an address at which the *Error Interrupt Status* register can be written. The effect of a write to this address will be reflected in the *Error Interrupt Status* Register if the corresponding bit of the *Error Interrupt Status Enable* Register is set.

Writing 1 : set each bit of the *Error Interrupt Status* Register

Writing 0 : no effect

Note: By setting this register, the Error Interrupt can be set in the *Error Interrupt Status* register. In order to generate interrupt signal, both the *Error Interrupt Status Enable* and *Error Interrupt Signal Enable* shall be set.

D15	D12	D11	D10	D09	D08	D07	D06	D05	D04	D03	D02	D01	D00	
Force Event for Vendor Specific Error Status		Rsvd			Force Event for ADMA Error	Force Event for Auto CMD Error	Force Event for Current limit Error	Force Event for Data End Bit Error	Force Event for Data CRC Error	Force Event for Data Timeout Error	Force Event for Command Index Error	Force Event for Command End Bit Error	Force Event for Command CRC Error	Force Event for Command Timeout Error

Figure 2-33 : Force Event Register for Error Interrupt Status

Location	Attrib	Register Field Explanation				
15-12	WO	<p>Force Event for Vendor Specific Error Status Additional status bits can be defined in this register by the vendor.</p> <table border="1"> <tr> <td>1</td> <td>Interrupt is generated</td> </tr> <tr> <td>0</td> <td>No Interrupt</td> </tr> </table>	1	Interrupt is generated	0	No Interrupt
1	Interrupt is generated					
0	No Interrupt					
11-10	Rsvd	Reserved				
09	WO	<p>Force Event for ADMA Error</p> <table border="1"> <tr> <td>1</td> <td>Interrupt is generated</td> </tr> <tr> <td>0</td> <td>No Interrupt</td> </tr> </table>	1	Interrupt is generated	0	No Interrupt
1	Interrupt is generated					
0	No Interrupt					
08	WO	<p>Force Event for Auto CMD Error</p> <table border="1"> <tr> <td>1</td> <td>Interrupt is generated</td> </tr> <tr> <td>0</td> <td>No Interrupt</td> </tr> </table>	1	Interrupt is generated	0	No Interrupt
1	Interrupt is generated					
0	No Interrupt					
07	WO	<p>Force Event for Current Limit Error</p> <table border="1"> <tr> <td>1</td> <td>Interrupt is generated</td> </tr> <tr> <td>0</td> <td>No Interrupt</td> </tr> </table>	1	Interrupt is generated	0	No Interrupt
1	Interrupt is generated					
0	No Interrupt					
06	WO	<p>Force Event for Data End Bit Error</p> <table border="1"> <tr> <td>1</td> <td>Interrupt is generated</td> </tr> <tr> <td>0</td> <td>No Interrupt</td> </tr> </table>	1	Interrupt is generated	0	No Interrupt
1	Interrupt is generated					
0	No Interrupt					
05	WO	<p>Force Event for Data CRC Error</p> <table border="1"> <tr> <td>1</td> <td>Interrupt is generated</td> </tr> <tr> <td>0</td> <td>No Interrupt</td> </tr> </table>	1	Interrupt is generated	0	No Interrupt
1	Interrupt is generated					
0	No Interrupt					

04	WO	Force Event for Data Timeout Error				
		<table border="1"> <tr> <td>1</td> <td>Interrupt is generated</td> </tr> <tr> <td>0</td> <td>No Interrupt</td> </tr> </table>	1	Interrupt is generated	0	No Interrupt
1	Interrupt is generated					
0	No Interrupt					
03	WO	Force Event for Command Index Error				
		<table border="1"> <tr> <td>1</td> <td>Interrupt is generated</td> </tr> <tr> <td>0</td> <td>No Interrupt</td> </tr> </table>	1	Interrupt is generated	0	No Interrupt
1	Interrupt is generated					
0	No Interrupt					
02	WO	Force Event for Command End Bit Error				
		<table border="1"> <tr> <td>1</td> <td>Interrupt is generated</td> </tr> <tr> <td>0</td> <td>No Interrupt</td> </tr> </table>	1	Interrupt is generated	0	No Interrupt
1	Interrupt is generated					
0	No Interrupt					
01	WO	Force Event for Command CRC Error				
		<table border="1"> <tr> <td>1</td> <td>Interrupt is generated</td> </tr> <tr> <td>0</td> <td>No Interrupt</td> </tr> </table>	1	Interrupt is generated	0	No Interrupt
1	Interrupt is generated					
0	No Interrupt					
00	WO	Force Event for Command Timeout Error				
		<table border="1"> <tr> <td>1</td> <td>Interrupt is generated</td> </tr> <tr> <td>0</td> <td>No Interrupt</td> </tr> </table>	1	Interrupt is generated	0	No Interrupt
1	Interrupt is generated					
0	No Interrupt					

Table 2-38 : Force Event for Error Interrupt Status Register

2.2.29 ADMA Error Status Register (Offset 054h)

When **ADMA Error** Interrupt is occurred, the **ADMA Error States** field in this register holds the ADMA state and the *ADMA System Address* Register holds the address around the error descriptor. For recovering the error, the Host Driver requires the ADMA state to identify the error descriptor address as follows:

- ST_STOP: Previous location set in the ADMA System Address register is the error descriptor address
- ST_FDS: Current location set in the ADMA System Address register is the error descriptor address
- ST_CADR: This state is never set because do not generate ADMA error in this state.
- ST_TFR: Previous location set in the ADMA System Address register is the error descriptor address

In case of write operation, the Host Driver should use ACMD22 to get the number of written block rather than using this information, since unwritten data may exist in the Host Controller.

The Host Controller generates the **ADMA Error** Interrupt when it detects invalid descriptor data (Valid=0) at the ST_FDS state. In this case, ADMA Error State indicates that an error occurs at ST_FDS state. The Host Driver may find that the Valid bit is not set in the error descriptor.

D07	D03	D02	D01	D00
Rsvd		ADMA Length Mismatch Error	ADMA Error States	

Figure 2-34 : ADMA Error Status Register

Location	Attrib	Register Field Explanation															
07-03	Rsvd	Reserved															
02	ROC	<p>ADMA Length Mismatch Error This error occurs in the following 2 cases.</p> <ol style="list-style-type: none"> (1) While Block Count Enable being set, the total data length specified by the Descriptor table is different from that specified by the <i>Block Count</i> and <i>Block Length</i>. (2) Total data length can not be divided by the block length. <table border="1" style="margin-left: 40px;"> <tr> <td>1</td> <td>Error</td> </tr> <tr> <td>0</td> <td>No Error</td> </tr> </table>	1	Error	0	No Error											
1	Error																
0	No Error																
01-00	ROC	<p>ADMA Error State This field indicates the state of ADMA when error is occurred during ADMA data transfer. This field never indicates "10" because ADMA never stops in this state.</p> <table border="1" style="margin-left: 40px;"> <thead> <tr> <th>D01 – D00</th> <th>ADMA Error State when error is occurred</th> <th>Contents of SYS_SDR register</th> </tr> </thead> <tbody> <tr> <td>00</td> <td>ST_STOP (Stop DMA)</td> <td>Points next of the error descriptor</td> </tr> <tr> <td>01</td> <td>ST_FDS (Fetch Descriptor)</td> <td>Points the error descriptor</td> </tr> <tr> <td>10</td> <td>Never set this state</td> <td>(Not used)</td> </tr> <tr> <td>11</td> <td>ST_TFR (Transfer Data)</td> <td>Points the next of the error descriptor</td> </tr> </tbody> </table>	D01 – D00	ADMA Error State when error is occurred	Contents of SYS_SDR register	00	ST_STOP (Stop DMA)	Points next of the error descriptor	01	ST_FDS (Fetch Descriptor)	Points the error descriptor	10	Never set this state	(Not used)	11	ST_TFR (Transfer Data)	Points the next of the error descriptor
D01 – D00	ADMA Error State when error is occurred	Contents of SYS_SDR register															
00	ST_STOP (Stop DMA)	Points next of the error descriptor															
01	ST_FDS (Fetch Descriptor)	Points the error descriptor															
10	Never set this state	(Not used)															
11	ST_TFR (Transfer Data)	Points the next of the error descriptor															

Table 2-39 : ADMA Error Status Register

2.2.30 ADMA System Address Register (Offset 058h)

This register contains the physical Descriptor address used for ADMA data transfer.

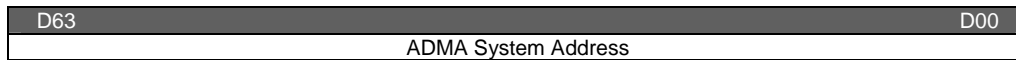

Figure 2-35 : ADMA System Address Register

Location	Attrib	Register Field Explanation																												
63-00	RW	<p>ADMA System Address</p> <p>This register holds byte address of executing command of the Descriptor table. 32-bit Address Descriptor uses lower 32-bit of this register. At the start of ADMA, the Host Driver shall set start address of the Descriptor table. The ADMA increments this register address, which points to next line, when every fetching a Descriptor line. When the ADMA Error Interrupt is generated, this register shall hold valid Descriptor address depending on the ADMA state. The Host Driver shall program Descriptor Table on 32-bit boundary and set 32-bit boundary address to this register. ADMA2 ignores lower 2-bit of this register and assumes it to be 00b.</p> <p>32-bit Address ADMA</p> <table border="1"> <thead> <tr> <th>Register Value</th> <th>32-bit System Address</th> </tr> </thead> <tbody> <tr> <td>xxxxxxxx 00000000h</td> <td>00000000h</td> </tr> <tr> <td>xxxxxxxx 00000004h</td> <td>00000004h</td> </tr> <tr> <td>xxxxxxxx 00000008h</td> <td>00000008h</td> </tr> <tr> <td>xxxxxxxx 0000000Ch</td> <td>0000000Ch</td> </tr> <tr> <td>.....</td> <td>.....</td> </tr> <tr> <td>xxxxxxxx FFFFFFFFCh</td> <td>FFFFFFFCh</td> </tr> </tbody> </table> <p>64-bit Address ADMA</p> <table border="1"> <thead> <tr> <th>Register Value</th> <th>64-bit System Address</th> </tr> </thead> <tbody> <tr> <td>00000000 00000000h</td> <td>00000000 00000000h</td> </tr> <tr> <td>00000000 00000004h</td> <td>00000000 00000004h</td> </tr> <tr> <td>00000000 00000008h</td> <td>00000000 00000008h</td> </tr> <tr> <td>00000000 0000000Ch</td> <td>00000000 0000000Ch</td> </tr> <tr> <td>.....</td> <td>.....</td> </tr> <tr> <td>FFFFFFFF FFFFFFFFCh</td> <td>FFFFFFFF FFFFFFFFCh</td> </tr> </tbody> </table>	Register Value	32-bit System Address	xxxxxxxx 00000000h	00000000h	xxxxxxxx 00000004h	00000004h	xxxxxxxx 00000008h	00000008h	xxxxxxxx 0000000Ch	0000000Ch	xxxxxxxx FFFFFFFFCh	FFFFFFFCh	Register Value	64-bit System Address	00000000 00000000h	00000000 00000000h	00000000 00000004h	00000000 00000004h	00000000 00000008h	00000000 00000008h	00000000 0000000Ch	00000000 0000000Ch	FFFFFFFF FFFFFFFFCh	FFFFFFFF FFFFFFFFCh
Register Value	32-bit System Address																													
xxxxxxxx 00000000h	00000000h																													
xxxxxxxx 00000004h	00000004h																													
xxxxxxxx 00000008h	00000008h																													
xxxxxxxx 0000000Ch	0000000Ch																													
.....																													
xxxxxxxx FFFFFFFFCh	FFFFFFFCh																													
Register Value	64-bit System Address																													
00000000 00000000h	00000000 00000000h																													
00000000 00000004h	00000000 00000004h																													
00000000 00000008h	00000000 00000008h																													
00000000 0000000Ch	00000000 0000000Ch																													
.....																													
FFFFFFFF FFFFFFFFCh	FFFFFFFF FFFFFFFFCh																													

Table 2-40 : ADMA System Address Register

2.2.31 Preset Value Registers (Offset 06F-060h)

Offset	Preset Value Registers	Signal Voltage
060h	Preset Value for Initialization	3.3V or 1.8V
062h	Preset Value for Default Speed	3.3V
064h	Preset Value for High Speed	3.3V
066h	Preset Value for SDR12	1.8V
068h	Preset Value for SDR25	1.8V
06Ah	Preset Value for SDR50	1.8V
06Ch	Preset Value for SDR104	1.8V
06Eh	Preset Value for DDR50	1.8V

Table 2-41 : Preset Value Registers

Table 2-41 shows a set of preset values per card or device. One of the *Preset Value* registers (06Eh - 062h) is effective based on the Selected Bus Speed Mode. Table 2-42 defines the conditions to select one of *Preset Value* registers and Figure 2-36 defines fields of a *Preset Value* register. When **Preset Value Enable** in the *Host Control 2* Register is set to 1, **SDCLK Frequency Select and Clock Generator Select** in the *Clock Control* Register, and **Driver Strength Select** in the *Host Control 2* Register are automatically set based on the Selected Bus Speed Mode. This means the Host Driver needs not set these fields when preset is enabled. A *Preset Value for Initialization* (060h) is not selected by bus speed mode. Before starting the initialization sequence, the Host Driver needs to set a clock preset value to **SDCLK Frequency Select** in the *Clock Control* Register. **Preset Value Enable** can be set after initialization completed.

Selected Bus Speed Mode	1.8V Signaling Enable (Host Control 2)	High Speed Enable (Host Control 1)	UHS-I Mode Selection (Host Control 2)
Default Speed	0	0	don't care
High Speed	0	1	don't care
SDR12	1	don't care	000b
SDR25	1	don't care	001b
SDR50	1	don't care	010b
SDR104	1	don't care	011b
DDR50	1	don't care	100b
Reserved	1	don't care	101b-111b

Table 2-42 : Preset Value Register Select Condition

D15 - D14	D13 - D11	D10	D09	D00
Driver Strength Select Value	Reserved	Clock Generator Select Value	SDCLK Frequency Select Value	

Figure 2-36 : Fields of A Preset Value Register

SD Host Controller Simplified Specification Version 3.00

Location	Attrib	Register Field Explanation								
15-14	Hwlnit	<p>Driver Strength Select Value Driver Strength is supported by 1.8V signaling bus speed modes. This field is meaningless for 3.3V signaling.</p> <table border="1"> <tr> <td>11b</td> <td>Driver Type D is Selected</td> </tr> <tr> <td>10b</td> <td>Driver Type C is Selected</td> </tr> <tr> <td>01b</td> <td>Driver Type A is Selected</td> </tr> <tr> <td>00b</td> <td>Driver Type B is Selected</td> </tr> </table>	11b	Driver Type D is Selected	10b	Driver Type C is Selected	01b	Driver Type A is Selected	00b	Driver Type B is Selected
11b	Driver Type D is Selected									
10b	Driver Type C is Selected									
01b	Driver Type A is Selected									
00b	Driver Type B is Selected									
13-11	Rsvd	Reserved								
10	Hwlnit	<p>Clock Generator Select Value This bit is effective when Host Controller supports programmable clock generator.</p> <table border="1"> <tr> <td>1</td> <td>Programmable Clock Generator</td> </tr> <tr> <td>0</td> <td>Host Controller Ver2.00 Compatible Clock Generator</td> </tr> </table>	1	Programmable Clock Generator	0	Host Controller Ver2.00 Compatible Clock Generator				
1	Programmable Clock Generator									
0	Host Controller Ver2.00 Compatible Clock Generator									
09-00	Hwlnit	<p>SDCLK Frequency Select Value 10-bit preset value to set SDCLK Frequency Select in the <i>Clock Control</i> Register is described by a host system.</p>								

Table 2-43 : Fields of A Preset Value Register

When Host Controller supports shared bus, a set of *Preset Value* registers for each device is required and the registers location are duplicated to the offset 06Fh-060h. A set of *Preset Value* registers can be accessible by selecting **Clock Pin Select** in the *Shared Bus Control* register.

SD Host Controller Simplified Specification Version 3.00**2.2.32 Shared Bus Control Register (Offset 0E0h)**

This register is optional. The devices on shared bus are not intended to be controlled by the Standard Host Driver. This is because shared bus configuration depends on a host system; the devices on shared bus may be controlled by a specific driver of a host system.

D31	D30 - D24	D23	D22-D20	D19	D18-D16	D15	D14-D08	D07-D06	D05-D04	D03	D02-D00
Rsvd	Back-End Power Control	Rsvd	Interrupt Pin Select	Rsvd	Clock Pin Select	Rsvd	Bus Width Preset	Rsvd	Number of Interrupt Input Pins	Rsvd	Number of Clock Pins

Figure 2-37 : Shared Bus Control Register

Location	Attrib	Register Field Explanation																		
31	Rsvd	Reserved																		
30-24	RW	<p>Back-End Power Control Each bit of this field controls back-end power supply for an embedded device. Host interface voltage (VDDH) is not controlled by this field. The number of devices supported is specified by Number of Clock Pins and a maximum of 7 devices can be controlled.</p> <table border="1"> <tr><td>D16</td><td>Back-end Power Control for Device 1</td></tr> <tr><td>D17</td><td>Back-end Power Control for Device 2</td></tr> <tr><td>D18</td><td>Back-end Power Control for Device 3</td></tr> <tr><td>D19</td><td>Back-end Power Control for Device 4</td></tr> <tr><td>D20</td><td>Back-end Power Control for Device 5</td></tr> <tr><td>D21</td><td>Back-end Power Control for Device 6</td></tr> <tr><td>D22</td><td>Back-end Power Control for Device 7</td></tr> </table> <p>The function of each bit is defined as follows:</p> <table border="1"> <tr><td>0</td><td>Back-end Power is Off</td></tr> <tr><td>1</td><td>Back-end Power is Supplied</td></tr> </table> <p>Back-End power control is effective for embedded memory devices in the Sleep State that support the Sleep command (CMD14) to reduce power consumption and embedded SDIO devices when IOEx is set to 0.</p>	D16	Back-end Power Control for Device 1	D17	Back-end Power Control for Device 2	D18	Back-end Power Control for Device 3	D19	Back-end Power Control for Device 4	D20	Back-end Power Control for Device 5	D21	Back-end Power Control for Device 6	D22	Back-end Power Control for Device 7	0	Back-end Power is Off	1	Back-end Power is Supplied
D16	Back-end Power Control for Device 1																			
D17	Back-end Power Control for Device 2																			
D18	Back-end Power Control for Device 3																			
D19	Back-end Power Control for Device 4																			
D20	Back-end Power Control for Device 5																			
D21	Back-end Power Control for Device 6																			
D22	Back-end Power Control for Device 7																			
0	Back-end Power is Off																			
1	Back-end Power is Supplied																			
23	Rsvd	Reserved																		
22-20	RW	<p>Interrupt Pin Select Interrupt pin inputs are enabled by this field. Enable of unsupported interrupt pin is meaningless.</p> <table border="1"> <tr><td>000b</td><td>Interrupt is detected by Interrupt Cycle</td></tr> <tr><td>xx1b</td><td>INT_A is Enabled</td></tr> <tr><td>x1xb</td><td>INT_B is Enabled</td></tr> <tr><td>1xxb</td><td>INT_C is Enabled</td></tr> </table>	000b	Interrupt is detected by Interrupt Cycle	xx1b	INT_A is Enabled	x1xb	INT_B is Enabled	1xxb	INT_C is Enabled										
000b	Interrupt is detected by Interrupt Cycle																			
xx1b	INT_A is Enabled																			
x1xb	INT_B is Enabled																			
1xxb	INT_C is Enabled																			
19	Rsvd	Reserved																		

SD Host Controller Simplified Specification Version 3.00

18-16	RW	<p>Clock Pin Select</p> <p>One of clock pin outputs is selected by this field. Select of unsupported clock pin is meaningless. Refer to Figure 2-38 for the timing of clock outputs.</p> <table border="1"> <tr> <td>000b</td> <td>Clock Pins are Disabled</td> </tr> <tr> <td>001b</td> <td>CLK[1] is Selected</td> </tr> <tr> <td>010b</td> <td>CLK[2] is Selected</td> </tr> <tr> <td>.....</td> <td>.....</td> </tr> <tr> <td>111b</td> <td>CLK[7] is Selected</td> </tr> </table>	000b	Clock Pins are Disabled	001b	CLK[1] is Selected	010b	CLK[2] is Selected	111b	CLK[7] is Selected								
000b	Clock Pins are Disabled																			
001b	CLK[1] is Selected																			
010b	CLK[2] is Selected																			
.....																			
111b	CLK[7] is Selected																			
15	Rsvd	Reserved																		
14-08	Hwlnit	<p>Bus Width Preset</p> <p>Shared bus supports mixing of 4-bit and 8-bit bus width devices. Each bit of this field specifies the bus width for each embedded device. The number of devices supported is specified by Number of Clock Pins and a maximum of 7 devices are supported.</p> <p>This field is effective when multiple devices are connected to a shared bus (Slot Type is set to 10b in the <i>Capabilities</i> register). In the other case, Extended Data Transfer Width in the <i>Host Control 1</i> register is used to select 8-bit bus width. As use of 1-bit mode is not intended for shared bus, Data Transfer Width in the <i>Host Control 1</i> register should be set to 1.</p> <table border="1"> <tr> <td>D24</td> <td>Bus Width Preset for Device 1</td> </tr> <tr> <td>D25</td> <td>Bus Width Preset for Device 2</td> </tr> <tr> <td>D26</td> <td>Bus Width Preset for Device 3</td> </tr> <tr> <td>D27</td> <td>Bus Width Preset for Device 4</td> </tr> <tr> <td>D28</td> <td>Bus Width Preset for Device 5</td> </tr> <tr> <td>D29</td> <td>Bus Width Preset for Device 6</td> </tr> <tr> <td>D30</td> <td>Bus Width Preset for Device 7</td> </tr> </table> <p>The function of each bit is defined as follows:</p> <table border="1"> <tr> <td>0</td> <td>4-bit bus width mode (Data Transfer Width = 1)</td> </tr> <tr> <td>1</td> <td>8-bit bus width mode</td> </tr> </table>	D24	Bus Width Preset for Device 1	D25	Bus Width Preset for Device 2	D26	Bus Width Preset for Device 3	D27	Bus Width Preset for Device 4	D28	Bus Width Preset for Device 5	D29	Bus Width Preset for Device 6	D30	Bus Width Preset for Device 7	0	4-bit bus width mode (Data Transfer Width = 1)	1	8-bit bus width mode
D24	Bus Width Preset for Device 1																			
D25	Bus Width Preset for Device 2																			
D26	Bus Width Preset for Device 3																			
D27	Bus Width Preset for Device 4																			
D28	Bus Width Preset for Device 5																			
D29	Bus Width Preset for Device 6																			
D30	Bus Width Preset for Device 7																			
0	4-bit bus width mode (Data Transfer Width = 1)																			
1	8-bit bus width mode																			
07-06	Rsvd	Reserved																		
05-04	Hwlnit	<p>Number of Interrupt Input Pins</p> <p>This field indicates support of interrupt input pins for shared bus system. Three asynchronous interrupt pins are defined, INT_A#, INT_B# and INT_C#. Which interrupt pin is used is determined by the system. Each one is driven by open drain and then wired or connection is possible.</p> <table border="1"> <tr> <td>00b</td> <td>Interrupt Input Pin is Not Supported</td> </tr> <tr> <td>01b</td> <td>INTA is Supported</td> </tr> <tr> <td>10b</td> <td>INTA and INTB are Supported</td> </tr> <tr> <td>11b</td> <td>INTA, INTB and INTC are Supported</td> </tr> </table>	00b	Interrupt Input Pin is Not Supported	01b	INTA is Supported	10b	INTA and INTB are Supported	11b	INTA, INTB and INTC are Supported										
00b	Interrupt Input Pin is Not Supported																			
01b	INTA is Supported																			
10b	INTA and INTB are Supported																			
11b	INTA, INTB and INTC are Supported																			
03	Rsvd	Reserved																		

SD Host Controller Simplified Specification Version 3.00

02-00	HwInit	Number of Clock Pins								
		<p>This field indicates support of clock pins to select one of devices for shared bus system. Up to 7 clock pins can be supported.</p> <p>Shared bus is supported by specific system. Then Standard Host Driver does not support control of these clock pins.</p> <table border="1"> <tr> <td>000b</td> <td>Shared bus is not supported</td> </tr> <tr> <td>001b</td> <td>1 SDCLK pin is supported</td> </tr> <tr> <td>010b</td> <td>2 SDCLK pins are supported</td> </tr> <tr> <td>.....</td> <td>.....</td> </tr> <tr> <td>111b</td> <td>7 SDCLK pins are supported</td> </tr> </table>	000b	Shared bus is not supported	001b	1 SDCLK pin is supported	010b	2 SDCLK pins are supported
000b	Shared bus is not supported									
001b	1 SDCLK pin is supported									
010b	2 SDCLK pins are supported									
.....									
111b	7 SDCLK pins are supported									

Table 2-44 : Shared Bus Control Register

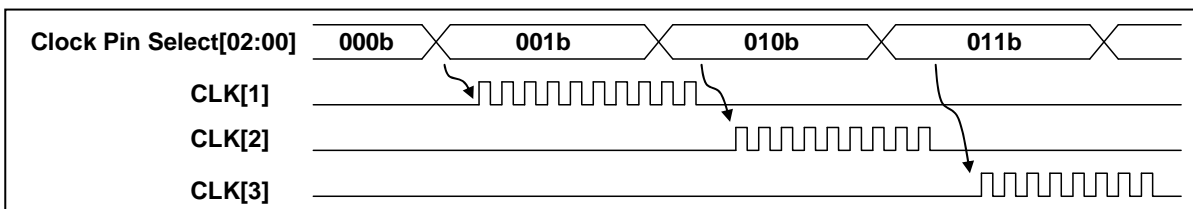

Figure 2-38 : An Example Timing of Selecting Clock Pin

Figure 2-38 shows an example timing of selecting clock pin. When **Clock Pin Select** is set to 000b, no clocks are generated from **CLK[7:0]** pins. When **Clock Pin Select** is set to 001b, Host Controller provides clock to only **CLK[1]**. This means the device 1 is selected. By setting 010b to **Clock Pin Select**, device 2 is selected. **CLK[1]** is stopped and then **CLK[2]** is generated. By setting 011b to **Clock Pin Select**, device 3 is selected. **CLK[2]** is stopped and then **CLK[3]** is generated. Clock outputs shall not be overlapped and no glitch shall be included. Clock frequency and output buffer strength are changed during clock stop interval.

Implementation Notes:

Lock-Reset pin is defined by eSD Version 2.10 to improve security level for updating boot loader and system codes. The Host System supporting Lock-Reset needs to consider following points.

Driving Lock-Reset to high during the device power off is not allowed to prevent protection diode of Lock-Reset input buffer from destroying. Lock-Reset signal can be driven to high after power is supplied to the device. Host interface voltage (VDDH) should be always supplied to the device. Then Host System should implement so that VDDH is not controlled by SD Bus Power bit in the Power Control register.

In case of eSD, sleep mode should be used instead of eSD device power off for saving power. Memory voltage VDDF can be off when the device is in Sleep State.

In case of SDIO, embedded SDIO can support back-end function power pin. The back-end function power can be off while IOEx=0.

2.2.33 Slot Interrupt Status Register (Offset 0FCh)

D15	D08	D07	D00
Rsvd		Interrupt Signal For Each Slot	

Figure 2-39 : Slot Interrupt Status Register

Location	Attrib	Register Field Explanation										
15-08	Rsvd	Reserved										
07-00	ROC	<p>Interrupt Signal For Each Slot These status bits indicate the logical OR of Interrupt Signal and Wakeup Signal for each slot. A maximum of 8 slots can be defined. If one interrupt signal is associated with multiple slots, the Host Driver can know which interrupt is generated by reading these status bits. By a power on reset or by setting Software Reset For All, the interrupt signal shall be de-asserted and this status shall read 00h.</p> <table border="1"> <tr> <td>Bit 00</td> <td>Slot 1</td> </tr> <tr> <td>Bit 01</td> <td>Slot 2</td> </tr> <tr> <td>Bit 02</td> <td>Slot 3</td> </tr> <tr> <td>.....</td> <td>.....</td> </tr> <tr> <td>Bit 07</td> <td>Slot 8</td> </tr> </table>	Bit 00	Slot 1	Bit 01	Slot 2	Bit 02	Slot 3	Bit 07	Slot 8
Bit 00	Slot 1											
Bit 01	Slot 2											
Bit 02	Slot 3											
.....											
Bit 07	Slot 8											

Table 2-45 : Slot Interrupt Status Register

2.2.34 Host Controller Version Register (Offset 0FEh)

D15	D08	D07	D00
Vendor Version Number		Specification Version Number	

Figure 2-40 : Host Controller Version Register

Location	Attrib	Register Field Explanation								
15-08	Hwlnit	<p>Vendor Version Number This status is reserved for the vendor version number. The Host Driver should not use this status.</p>								
07-00	Hwlnit	<p>Specification Version Number This status indicates the Host Controller Spec. Version. The upper and lower 4-bits indicate the version.</p> <table border="1"> <tr> <td>00h</td> <td>SD Host Specification Version 1.00</td> </tr> <tr> <td>01h</td> <td>SD Host Specification Version 2.00 Including the feature of the ADMA and Test Register,</td> </tr> <tr> <td>02h</td> <td>SD Host Specification Version 3.00</td> </tr> <tr> <td>others</td> <td>Reserved</td> </tr> </table>	00h	SD Host Specification Version 1.00	01h	SD Host Specification Version 2.00 Including the feature of the ADMA and Test Register,	02h	SD Host Specification Version 3.00	others	Reserved
00h	SD Host Specification Version 1.00									
01h	SD Host Specification Version 2.00 Including the feature of the ADMA and Test Register,									
02h	SD Host Specification Version 3.00									
others	Reserved									

Table 2-46 : Host Controller Version

3. SEQUENCE

This section defines basic sequence flow chart divided into several sub sequences.

"Wait for interrupts" is used in the flow chart. This means the Host Driver waits until specified interrupts are asserted. If already asserted, then fall through that step in the flow chart. Timeout checking shall be always required to detect no interrupt generated but this is not described in the flow chart.

This specification uses the double box like Figure 3-1, (the step (1) in Figure 3-5 and the step (5) in Figure 3-25), It means that the other flows, which already are shown, shall be performed. Therefore, the interrupt may be included in the other flows.

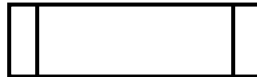

Figure 3-1 : Double Box Notation

3.1 SD Card Detection

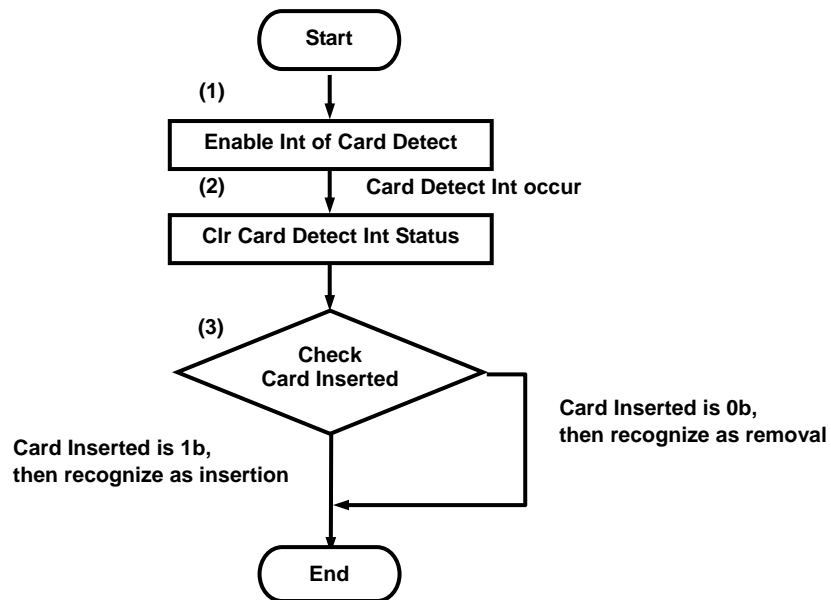

Figure 3-2: SD Card Detect Sequence

The flow chart for detecting a SD card is shown in Figure 3-2. Each step is executed as follows:

To enable interrupt for card detection, write 1 to the following bits:

- Card Insertion Status Enable** in the *Normal Interrupt Status Enable* register
- Card Insertion Signal Enable** in the *Normal Interrupt Signal Enable* register
- Card Removal Status Enable** in the *Normal Interrupt Status Enable* register
- Card Removal Signal Enable** in the *Normal Interrupt Signal Enable* register

SD Host Controller Simplified Specification Version 3.00

- (1) When the Host Driver detects the card insertion or removal, clear its interrupt statuses. If **Card Insertion** interrupt is generated, write 1 to **Card Insertion** in the *Normal Interrupt Status* register. If **Card Removal** interrupt is generated, write 1 to **Card Removal** in the *Normal Interrupt Status* register.
- (2) Check **Card Inserted** in the *Present State* register. In the case where **Card Inserted** is 1, the Host Driver can supply the power and the clock to the SD card. In the case where **Card Inserted** is 0, the other executing processes of the Host Driver shall be immediately closed.

If miniSD adaptor is used for standard SD slot and miniSD card is inserted or extracted from the adaptor, card detect interrupt may not be generated. When host does not receive response to any commands, miniSD card is extracted or in idle state, the host should try to re-initialize the card. In this case, all card information shall be re-loaded.

3.2 SD Clock Control

3.2.1 SD Clock Supply Sequence

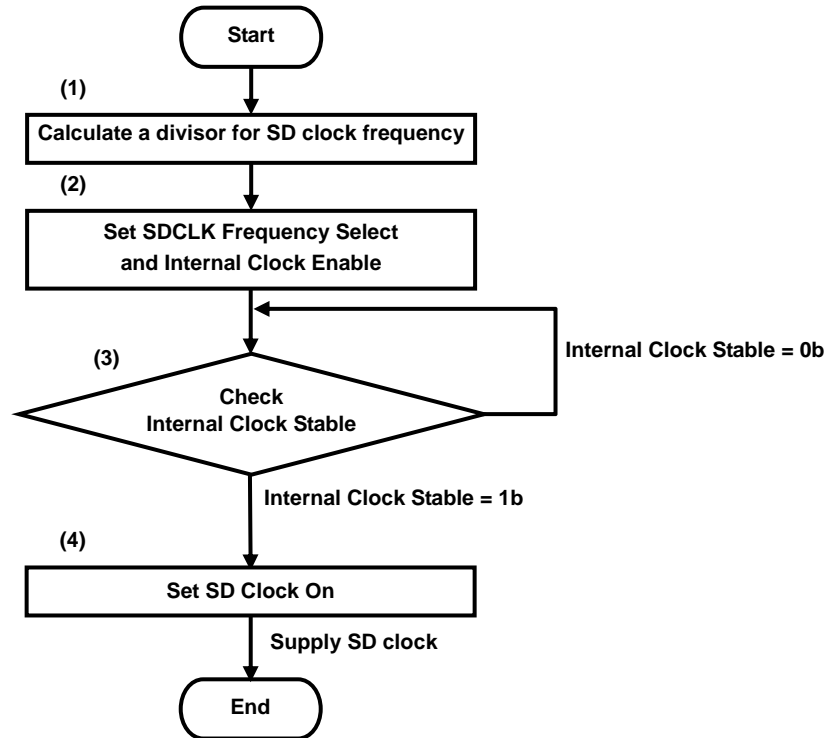

Figure 3-3: SD Clock Supply Sequence

The sequence for supplying SD Clock to a SD card is described in Figure 3-3. The clock shall be supplied to the card before either of the following actions is taken.

- a) Issuing a SD command
- b) Detect an interrupt from a SD card in 4-bit mode.

- (1) Calculate a divisor to determine SD Clock frequency by reading **Base Clock Frequency For SD Clock** in the *Capabilities* register. If **Base Clock Frequency For SD Clock** is 00 0000b, the Host System shall provide this information to the Host Driver by another method.
- (2) Set **Internal Clock Enable** and **SDCLK Frequency Select** in the *Clock Control* register in accordance with the calculated result of step (1).
- (3) Check **Internal Clock Stable** in the *Clock Control* register. Repeat this step until Clock Stable is 1.
- (4) Set **SD Clock Enable** in the *Clock Control* register to 1. Then, the Host Controller starts to supply the SD Clock.

3.2.2 SD Clock Stop Sequence

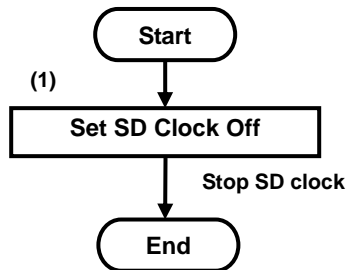

Figure 3-4: SD Clock Stop Sequence

The flow chart for stopping the SD Clock is shown in Figure 3-4. The Host Driver shall not stop the SD Clock when a SD transaction is occurring on the SD Bus -- namely, when either **Command Inhibit (DAT)** or **Command Inhibit (CMD)** in the *Present State* register is set to 1.

- (1) Set **SD Clock Enable** in the *Clock Control* register to 0. Then, the Host Controller stops supplying the SD Clock.

3.2.3 SD Clock Frequency Change Sequence

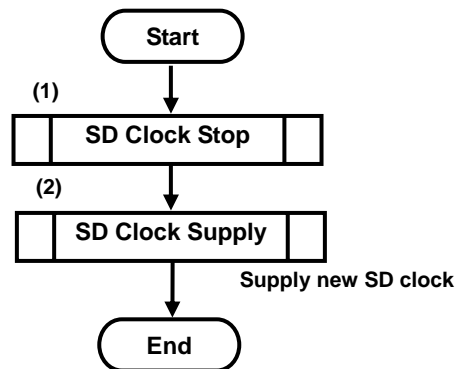

Figure 3-5: SD Clock Change Sequence

The sequence for changing SD Clock frequency is shown in Figure 3-5. When SD Clock is still off, step (1) is omitted. Please refer to Section 3.2.2 for details regarding step (1) and Section 3.2.1 for step (2).

3.3 SD Bus Power Control

The sequence for controlling the SD Bus Power is described in Figure 3-6.

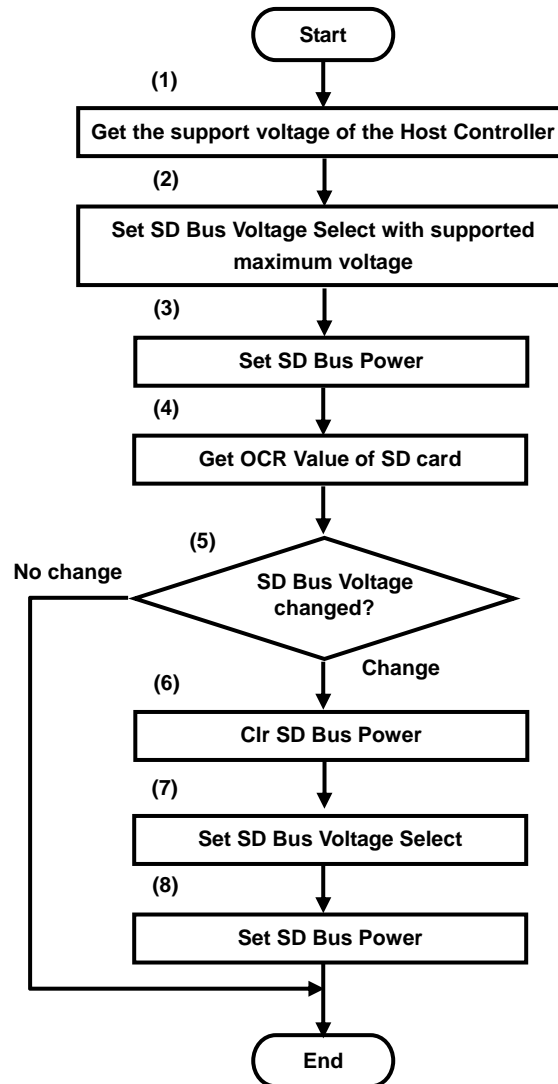

Figure 3-6: SD Bus Power Control Sequence

- (1) By reading the *Capabilities* register, get the support voltage of the Host Controller.
- (2) Set **SD Bus Voltage Select** in the *Power Control* register with maximum voltage that the Host Controller supports.
- (3) Set **SD Bus Power** in the *Power Control* register to 1.
- (4) Get the OCR value of all function internal of SD card.
- (5) Judge whether SD Bus voltage needs to be changed or not. In case where SD Bus voltage needs to be changed, go to step (6). In case where SD Bus voltage does not need to be changed, go to 'End'.
- (6) Set **SD Bus Power** in the *Power Control* register to 0 for clearing this bit. The card requires voltage rising from 0 volt to detect it correctly. The Host Driver shall clear **SD Bus Power** before changing voltage by setting **SD Bus Voltage Select**.
- (7) Set **SD Bus Voltage Select** in the *Power Control* register.
- (8) Set **SD Bus Power** in the *Power Control* register to 1.

Note:

Step (2) and step (3) can be executed at same time. And also, step (7) and step (8) can be executed at same time.

3.4 Changing Bus Width

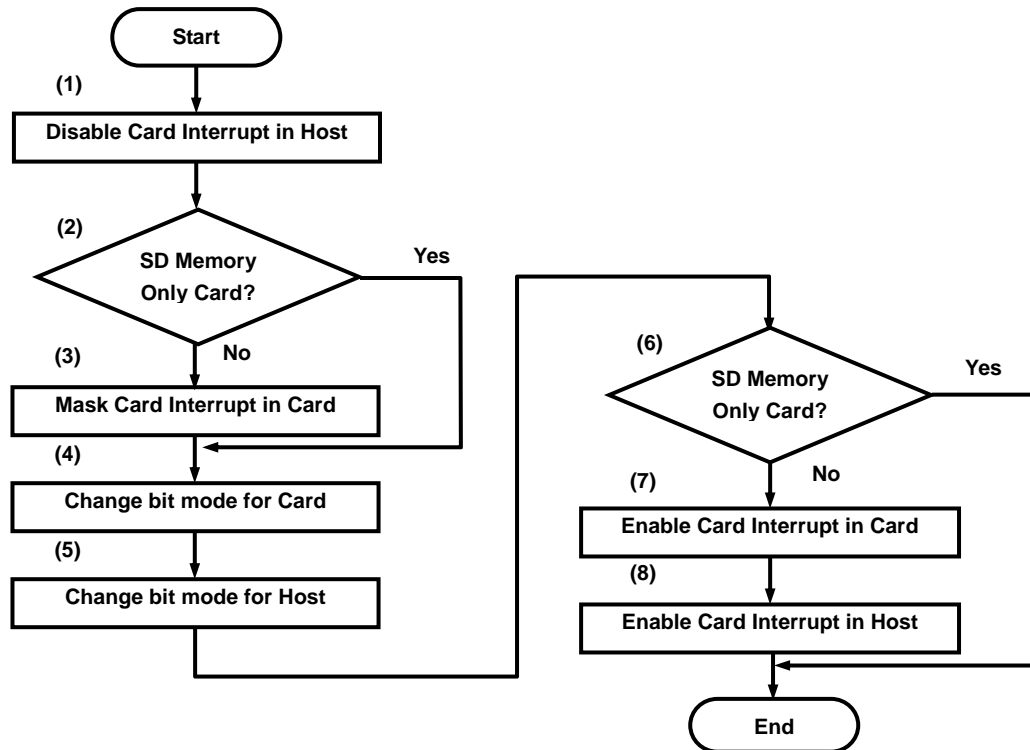

Figure 3-7: Change Bus Width Sequence

The sequence for changing bit mode on SD Bus is shown in Figure 3-7.

- (1) Set **Card Interrupt Status Enable** in the *Normal Interrupt Status Enable* register to 0 for masking incorrect interrupts that may occur while changing the bus width.
- (2) In case of SD memory only card, go to step (4). In case of other card, go to step (3).
- (3) Set "IENM" of the CCCR in a SDIO or SD combo card to 0 by CMD52. Please refer to Section 3.7.1 for how to generate CMD52.
- (4) Change the bus width mode for a SD card. SD Memory Card bus width is changed by ACMD6 and SDIO card bus width is changed by setting **Bus Width** of *Bus Interface Control* register in CCCR.
- (5) In case of changing to 4-bit mode, set **Data Transfer Width** to 1 in the *Host Control 1* register. In another case (1-bit mode), set this bit to 0.
- (6) In case of SD memory only card, go to the 'End'. In case of other card, go to step (7).
- (7) Set "IENM" of the CCCR in a SDIO or SD combo card to 1 by CMD52.
- (8) Set **Card Interrupt Status Enable** in the *Normal Interrupt Status Enable* register to 1.

Note that if the card is locked, bus width cannot be changed. Unlock the card is required before changing bus width.

3.5 Timeout Setting on DAT Line

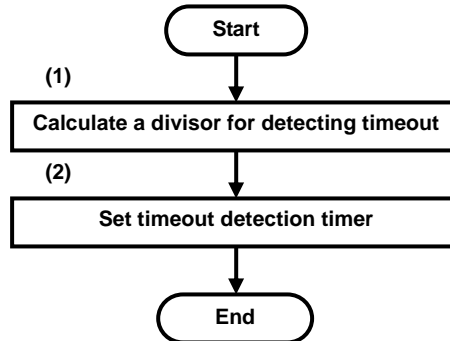

Figure 3-8: Timeout Setting Sequence

In order to detect timeout errors on DAT line, the Host Driver shall execute the following two steps before any SD transaction. For more information regarding SD transactions, refer to Section 3.7.2

- (1) Calculate a divisor to detect timeout errors by reading **Timeout Clock Frequency** and **Timeout Clock Unit** in the *Capabilities* register. If **Timeout Clock Frequency** is 00 0000b, the Host System shall provide this information to the Host Driver by another method.
- (2) Set **Data Timeout Counter Value** in the *Timeout Control* register in accordance with the value from step (1) above.

3.6 Card Initialization and Identification

Figure 3-9 shows new initialization and card identification sequence for the Standard Capacity SD Memory Card (SDSC), the High Capacity SD Memory Card (SDHC) and the Extended Capacity SD Memory Card (SDXC).

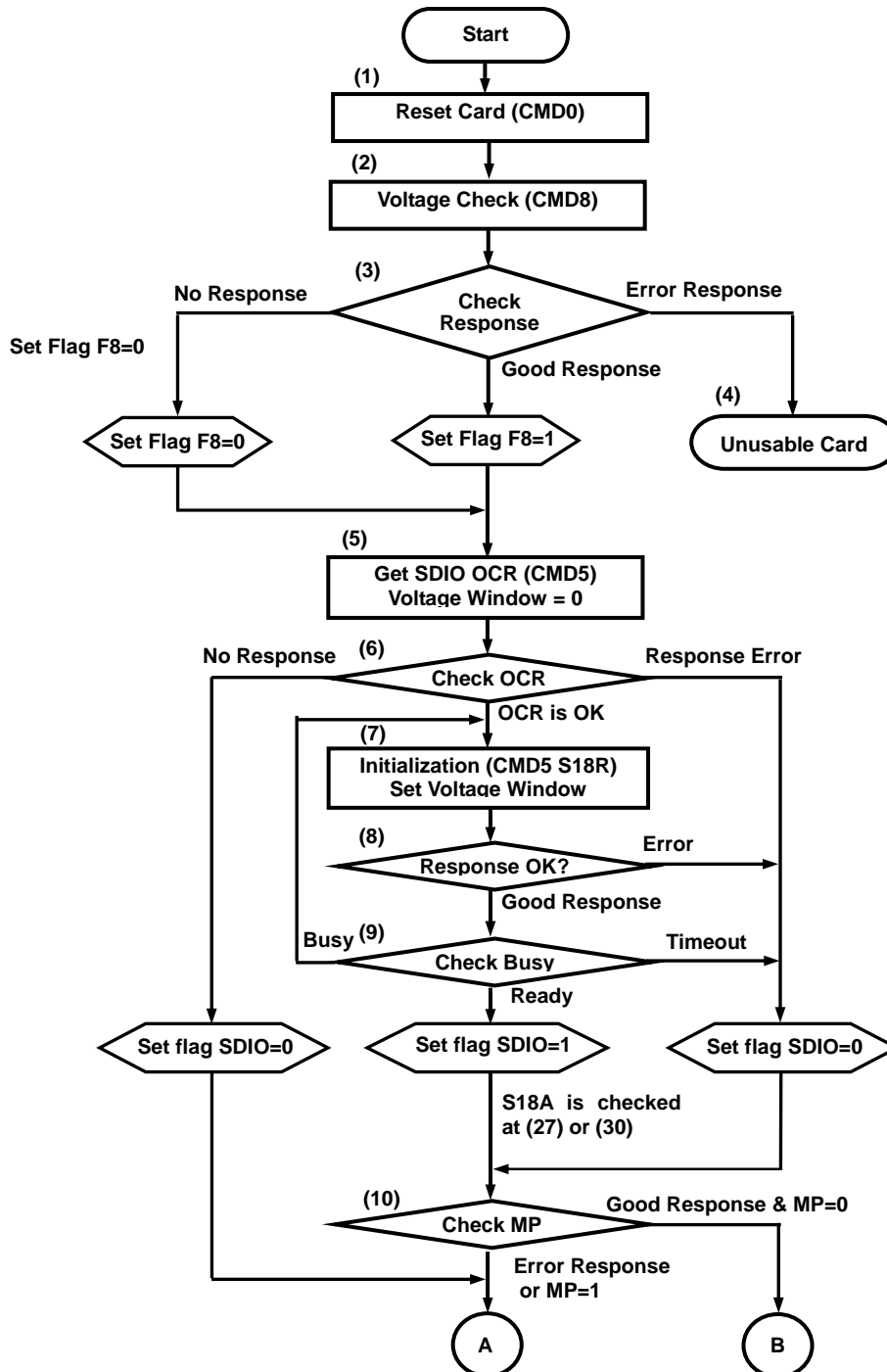

SD Host Controller Simplified Specification Version 3.00

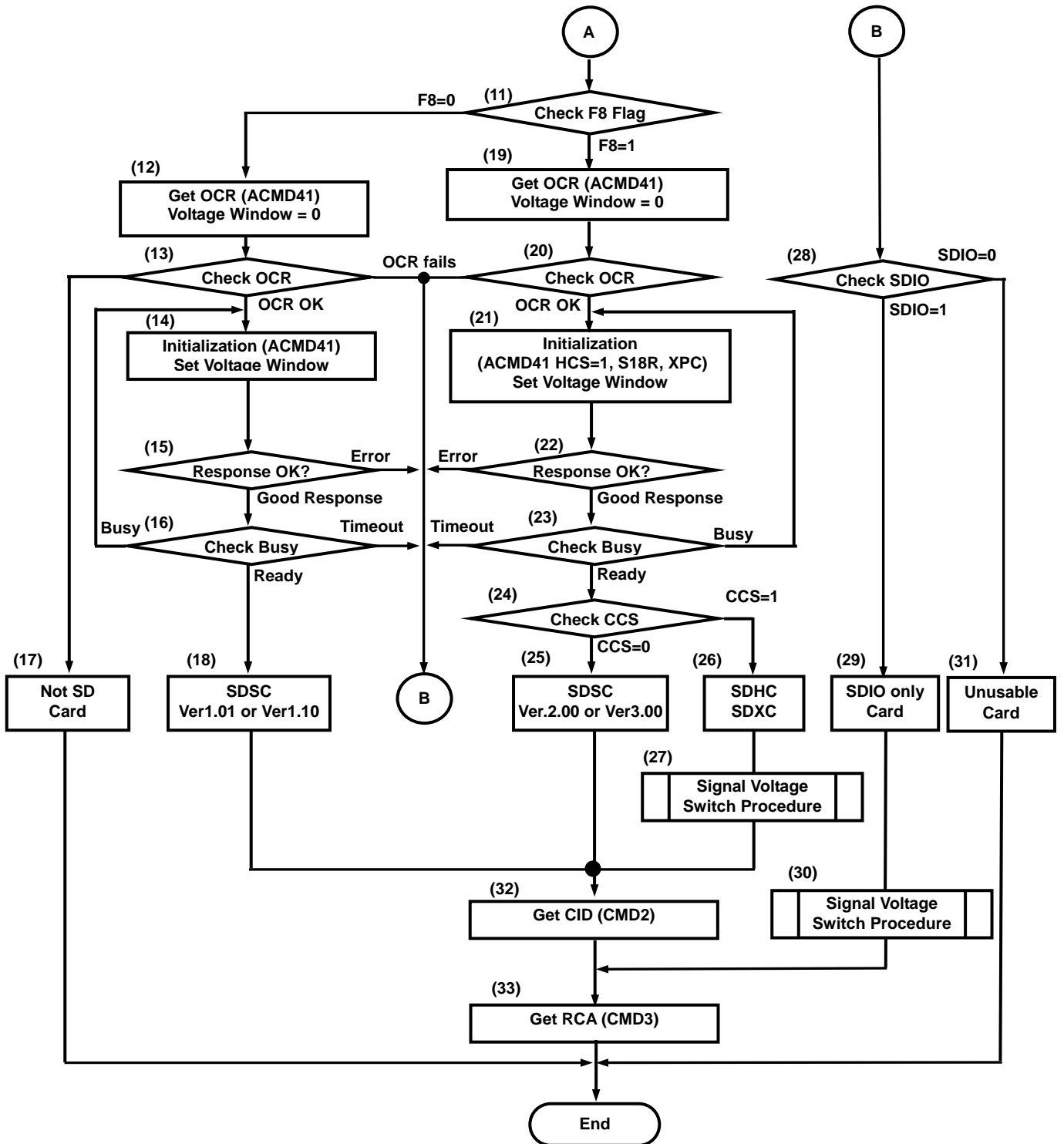

Figure 3-9 : Card Initialization and Identification

- (1) SD Bus mode is selected by CMD0 (Keep Pin 1 to high during CMD0 execution).
- (2) New CMD8 shall be issued after CMD0 to support High Capacity SD Memory Card.
- (3) Voltage check command enables the Hosts to support future low voltage specification. However, at this time, only one voltage is defined. Legacy cards and Not SD cards do not respond to CMD8. In this case, set F8 to 0 (F8 is CMD8 valid flag used in step (11)) and go to Step (5). Only Version 2.00 or higher cards can respond to CMD8. The host needs to check whether CRC of the response is valid and whether VHS and check pattern in the argument are equal to VCA and check pattern in the response. Passing all these checks results in CMD8 response OK. In this case, set F8 to 1 and go to step (5). If one of the checks is failed, go to step (4).
- (4) Initialization is stopped by CMD8 fails. The host driver should retry step (1) to (3) one more time. (This is not described in the figure).
- (5) SDIO OCR is available by issuing CMD5 with setting voltage window (bit 23 to 0) in the argument to 0. SDIO initialization is not started.
- (6) No response means the card does not have SDIO function. Set SDIO flag to 0 and go to step (11). If the card responds to CMD5 and the response is OK, go to step (7). If the response is error, set SDIO flag to 0 and go to step (10). SDIO flag indicates whether SDIO functions are initialized or not.
- (7) The SDIO portion starts initialization by CMD5 with setting the supply voltage to the voltage window. UHS-I supported host sets S18R to 1. If the supplied voltage is not matched with voltage window of card, the card goes into inactive state and does not return the response.
- (8) If no response or error response is received, set SDIO flag to 0 and go to step (10). If good response is received, go to step (9).
- (9) Check busy status in the response. If busy is released, set SDIO flag to 1 and go to step (10). Repeat from step (7) while busy is indicated. Detecting timeout of 1 second exits the loop. In this case, set SDIO flag to 0 and go to step (10).
- (10) Good response in this step means that all responses received at (6) and (8) are valid. When response is good, MP (memory present) flag in the response can be checked. If the response is valid and MP=0, go to step (28). Otherwise, go to step (11).
- (11) Check F8 flag set in step (3). If CMD8 is executed correctly (F8=1), go to step (19). Otherwise, go to step (12).
- (12) OCR is available by issuing ACMD41 with the voltage window (bit 23 to 0) in the argument is set to 0. Memory initialization is not started. The response of CMD55 (ACMD41) may indicate illegal command error due to some SD cards do not recognize CMD8. The Host Driver should ignore this error or issue CMD0 before ACMD41 to clear this error status.
- (13) If response of CMD55 is not received, the card is not SD card and goes to (17). If the card responds to CMD55, it may also respond to CMD41. If the responses of ACMD41 are OK, go to Step (14). Otherwise, go to step (28). Locked card can be detected by the card status in the response of CMD55.
- (14) The memory portion starts initialization by Issuing ACMD41 with setting the supply voltage to the voltage window. If the supplied voltage is not matched with voltage window of card, the card goes into inactive state and does not return the response.
- (15) If no response or error response is received, go to step (28). If good response is received, go to step (16).
- (16) Check busy status in the response. If busy is released, go to step (18). Repeat from step (14) while busy is indicated. The interval of ACMD41 shall be less than 50ms. Detecting timeout of 1 second exits the loop and go to step (28).
- (17) The host recognizes that the card is not SD memory card and quits SD card initialization.
- (18) The host recognizes that the card is Version 1.xx Standard Capacity SD Memory Card. Go to Step (30).
- (19) OCR is available by issuing ACMD41 with setting the voltage window (bit 23 to 0) in the argument is set to 0. Memory initialization is not started. Setting of HCS does not affect this operation.
- (20) If the card responds to CMD55, it may also respond to CMD41. If the responses of ACMD41 are

SD Host Controller Simplified Specification Version 3.00

- OK, go to Step (21). Otherwise, go to step (28). Locked card can be detected by the card status in the response of CMD55.
- (21) The memory portion starts initialization by Issuing ACMD41 with setting the supply voltage to the voltage window. UHS-I supported host sets S18R to 1. If the host can supply more than 150mA, XPC is set to 1. HCS in the argument is set to 1, which indicates supporting High Capacity Memory Card. If the supplied voltage is not matched with voltage window of card, the card goes into inactive state and does not return the response.
 - (22) If no response or error response is received, go to step (28). If good response is received, go to step (23).
 - (23) Check busy status in the response. If busy is released, go to step (24). Repeat from step (21) while busy is indicated. The interval of ACMD41 shall be less than 50ms. Detecting timeout of 1 second exits the loop and go to step (28).
 - (24) CCS in the response is valid after busy is released. If CCS = 0, it indicates the Standard Capacity SD Memory Card and go to step (25). If CCS = 1, it indicates the High Capacity SD Memory Card or Extended Capacity Memory Card and go to Step (26).
 - (25) The host recognizes that the card is Ver2.00 or Ver3.00 Standard Capacity SD Memory Card. Optimal functions defined in Version 2.00 or higher are available. Go to Step (32).
 - (26) The host recognizes that the card is the High Capacity SD Memory Card or Extended Capacity Memory Card.
 - (27) Perform the signal voltage switch procedure and go to step (32).
 - (28) Check SDIO flag. If SDIO=1, go to step (28). Otherwise, go to step (31).
 - (29) The host recognizes that the card is SDIO only card and go to step (30).
 - (30) Perform the signal voltage switch procedure and go to step (33).
 - (31) The host recognizes that the card is unusable.
 - (32) In case of memory card, CMD2 is issued to get CID and Go to Step (31).
 - (33) CMD3 is issued to get RCA. If the RCA number is 0, the Host should issue CMD3 again.

3.6.1 Signal Voltage Switch Procedure

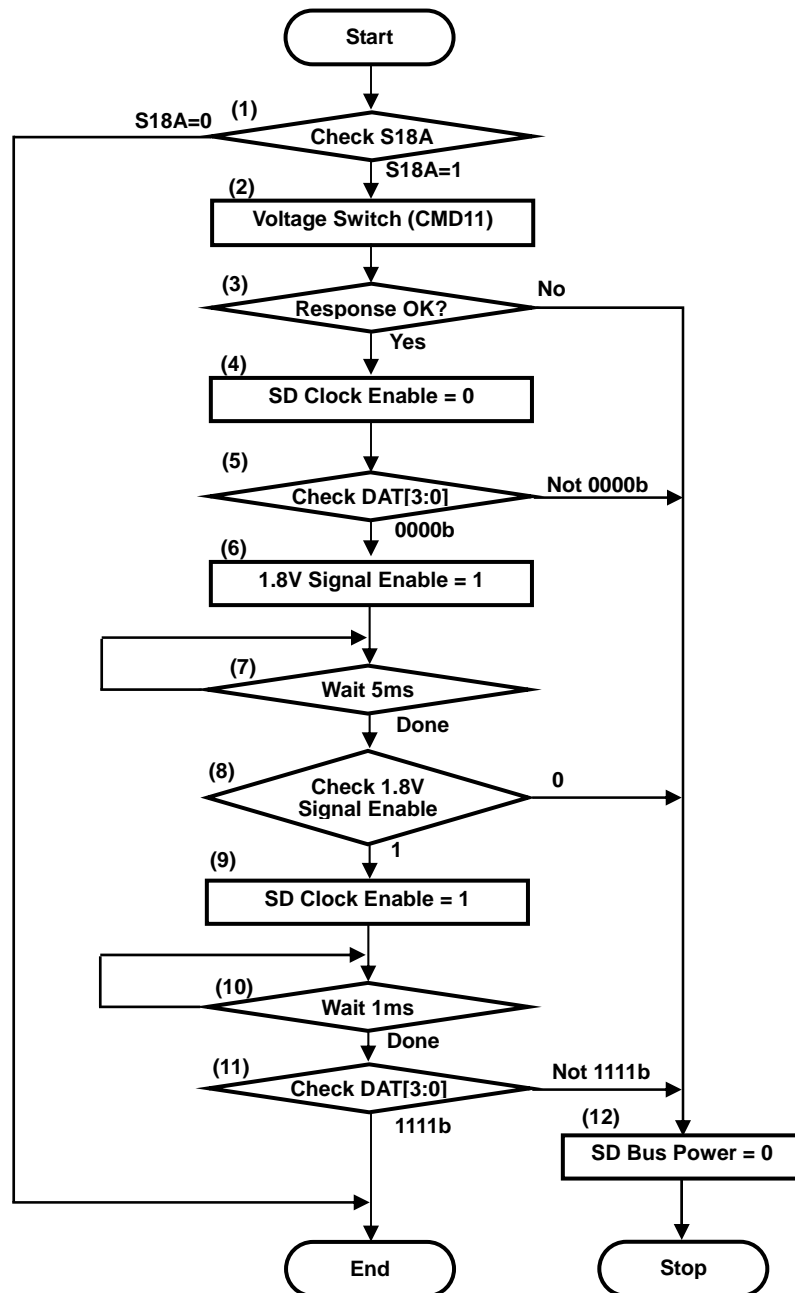

Figure 3-10 : Signal Voltage Switch Procedure

- (1) If S18A of CMD5 or S18A of ACMD41 is set to 1, signal voltage switch is performed according to the following steps. Otherwise, exits from this procedure.
- (2) Issue CMD11.
- (3) Check response and if an error is detected, go to step (12)
- (4) Stop providing SD clock to the card.
- (5) Check DAT[3:0] level. If the level is 0000b, the card is ready to start voltage switch sequence. Otherwise, go to (12) to quit the sequence.
- (6) Set **1.8V Signal Enable** in the *Host Control 2* register.
- (7) Wait 5ms. 1.8V voltage regulator shall be stable within this period.
- (8) If **1.8V Signal Enable** is cleared by Host Controller, go to step (12).
- (9) Provide SD Clock to the card again.
- (10) Wait 1ms.
- (11) Check DAT[3:0] level. If the level is 1111b, switch to 1.8V signal level is completed successfully. Otherwise, go to (12).
- (12) If an error occurs during voltage switch procedure, stop providing the power to the card. In this case, Host Driver should retry initialization procedure by setting S18R to 0 at step (7) and (21) in Figure 3-9.

3.7 SD Transaction Generation

This section describes the sequences how to generate and control various kinds of SD transactions. SD transactions are classified into three cases:

- (1) Transactions that do not use the DAT line.
- (2) Transactions that use the DAT line only for the busy signal.
- (3) Transactions that use the DAT line for transferring data.

In this specification the first and the second case's transactions are classified as "Transaction Control without Data Transfer using DAT Line", the third case's transaction is classified as "Transaction Control with Data Transfer using DAT Line".

Refer to the latest SD Physical Layer Specification and SDIO Specification for more detail about SD commands specification.

3.7.1 Transaction Control without Data Transfer Using DAT Line

In this section, the sequence for how to issue SD Command and how to complete SD Command is explained. Figure 3-11 shows the sequence to issue a SD Command and Figure 3-12 shows the sequence to finalize a SD Command.

3.7.1.1 The Sequence to Issue a SD Command

The sequence to issue the SD Command is detailed below.

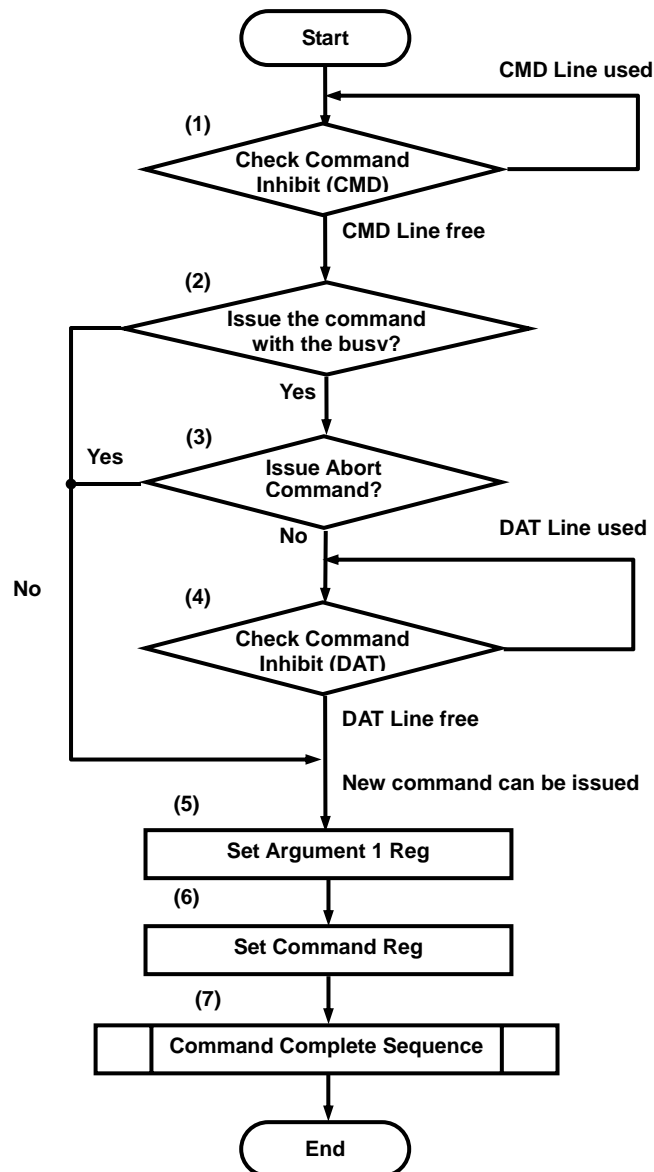

Figure 3-11: SD Command Issue Sequence

- (1) Check **Command Inhibit (CMD)** in the *Present State* register. Repeat this step until **Command Inhibit (CMD)** is 0. That is, when **Command Inhibit (CMD)** is 1, the Host Driver shall not issue a SD Command.
- (2) If the Host Driver issues a SD Command with busy signal, go to step (3). If without busy signal, go to step (5).
- (3) If the Host Driver issues an abort command, go to step (5). In the case of no abort command, go to step (4).
- (4) Check **Command Inhibit (DAT)** in the *Present State* register. Repeat this step until **Command Inhibit (DAT)** is set to 0.
- (5) Set the value of command argument to the *Argument 1* register.
- (6) Set the *Command* register.
Note: Writing the upper byte [3] in the *Command* register causes the host controller to issue a SD command to the SD card.
- (7) Perform Command Completion Sequence in accordance with 3.7.1.2.

3.7.1.2 The Sequence to Finalize a Command

Figure 3-12 shows the sequence to finalize a SD Command. There is a possibility that some errors (Command Index/End bit/CRC/Timeout Error) occur during this sequence.

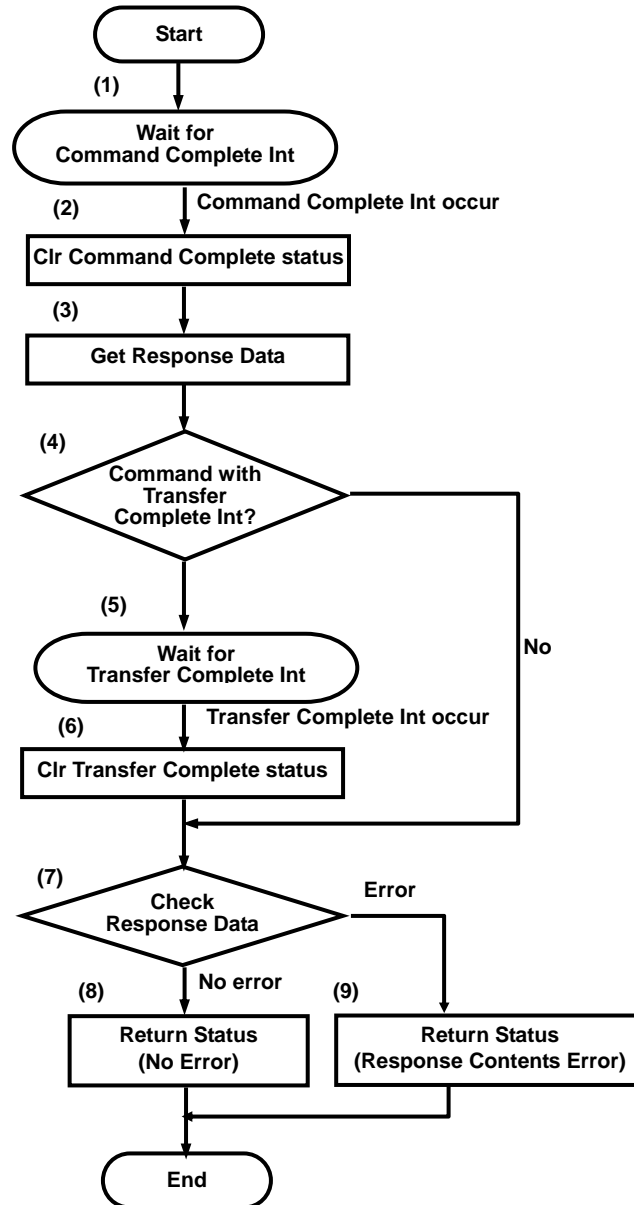

Figure 3-12: Command Complete Sequence

- (1) Wait for the **Command Complete** Interrupt. If the **Command Complete** Interrupt has occurred, go to step (2).
- (2) Write 1 to **Command Complete** in the *Normal Interrupt Status* register to clear this bit.
- (3) Read the *Response* register and get necessary information of the issued command.
- (4) Judge whether the command uses the **Transfer Complete** Interrupt or not. If it uses **Transfer Complete**, go to step (5). If not, go to step (7).
- (5) Wait for the **Transfer Complete** Interrupt. If the **Transfer Complete** Interrupt has occurred, go to step (6).
- (6) Write 1 to **Transfer Complete** in the *Normal Interrupt Status* register to clear this bit.
- (7) Check for errors in Response Data. If there is no error, go to step (8). If there is an error, go to step (9).
- (8) Return Status of "No Error".
- (9) Return Status of "Response Contents Error".

Note1: While waiting for the **Transfer Complete** interrupt, the Host Driver shall only issue commands that do not use the busy signal.

Note2: The Host Driver shall judge the Auto CMD12 complete by monitoring Transfer Complete.

Note3: When the last block of un-protected area is read using memory multiple block read command (CMD18), OUT_OF_RANGE error may occur even if the sequence is correct. The Host Driver should ignore it. This error will appear in the response of Auto CMD12 or in the response of the next memory command.

3.7.2 Transaction Control with Data Transfer Using DAT Line

Depending on whether DMA (optional) is used or not, there are two execution methods. The sequence not using DMA is shown in Figure 3-13 and the sequence using DMA is shown in Figure 3-14.

In addition, the sequences for SD transfers are classified into following three kinds according to how the number of blocks is specified:

- (1) Single Block Transfer:
The number of blocks is specified to the Host Controller before the transfer. The number of blocks specified is always one.
- (2) Multiple Block Transfer:
The number of blocks is specified to the Host Controller before the transfer. The number of blocks specified shall be one or more.
- (3) Infinite Block Transfer:
The number of blocks is not specified to the Host Controller before the transfer. This transfer is continued until an abort transaction is executed. This abort transaction is performed by CMD12 in the case of a SD memory card, and by CMD52 in the case of a SDIO card.

3.7.2.1 Not using DMA

The sequence for not using DMA is shown below.

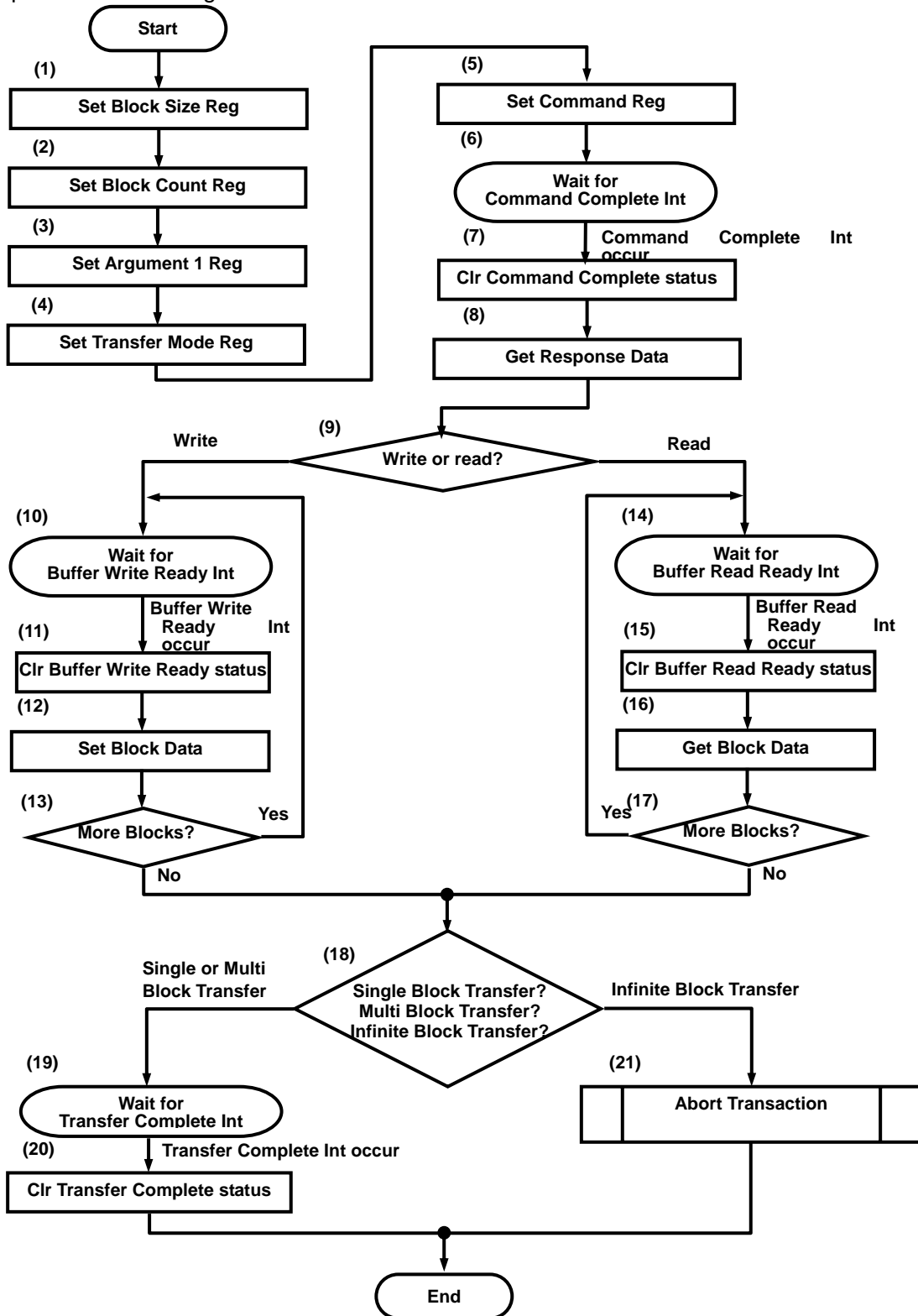

Figure 3-13: Transaction Control with Data Transfer Using DAT Line Sequence (Not using DMA)

- (1) Set the value corresponding to the executed data byte length of one block to *Block Size* register.
- (2) Set the value corresponding to the executed data block count to *Block Count* register in accordance with Table 2-8.
- (3) Set the argument value to *Argument 1* register.
- (4) Set the value to the *Transfer Mode* register. The host driver determines **Multi / Single Block Select, Block Count Enable, Data Transfer Direction, Auto CMD12 Enable** and **DMA Enable**. **Multi / Single Block Select** and **Block Count Enable** are determined according to Table 2-8.
- (5) Set the value to *Command* register.
Note: When writing the upper byte [3] of *Command* register, SD command is issued.
- (6) Then, wait for the Command Complete Interrupt.
- (7) Write 1 to the **Command Complete** in the *Normal Interrupt Status* register for clearing this bit.
- (8) Read *Response* register and get necessary information of the issued command.
- (9) In the case where this sequence is for write to a card, go to step (10). In case of read from a card, go to step (14).
- (10) Then wait for **Buffer Write Ready** Interrupt.
- (11) Write 1 to the **Buffer Write Ready** in the *Normal Interrupt Status* register for clearing this bit.
- (12) Write block data (in according to the number of bytes specified at the step (1)) to *Buffer Data Port* register.
- (13) Repeat until all blocks are sent and then go to step (18).
- (14) Then wait for the **Buffer Read Ready** Interrupt.
- (15) Write 1 to the **Buffer Read Ready** in the *Normal Interrupt Status* register for clearing this bit.
- (16) Read block data (in according to the number of bytes specified at the step (1)) from the *Buffer Data Port* register.
- (17) Repeat until all blocks are received and then go to step (18).
- (18) If this sequence is for Single or Multiple Block Transfer, go to step (19). In case of Infinite Block Transfer, go to step (21).
- (19) Wait for **Transfer Complete** Interrupt.
- (20) Write 1 to the **Transfer Complete** in the *Normal Interrupt Status* register for clearing this bit.
- (21) Perform the sequence for Abort Transaction in accordance with Section 3.8.
Note: Step (1) and Step (2) can be executed at same time. Step (4) and Step (5) can be executed at same time.

3.7.2.2 Using SDMA

The sequence for using SDMA is shown below.

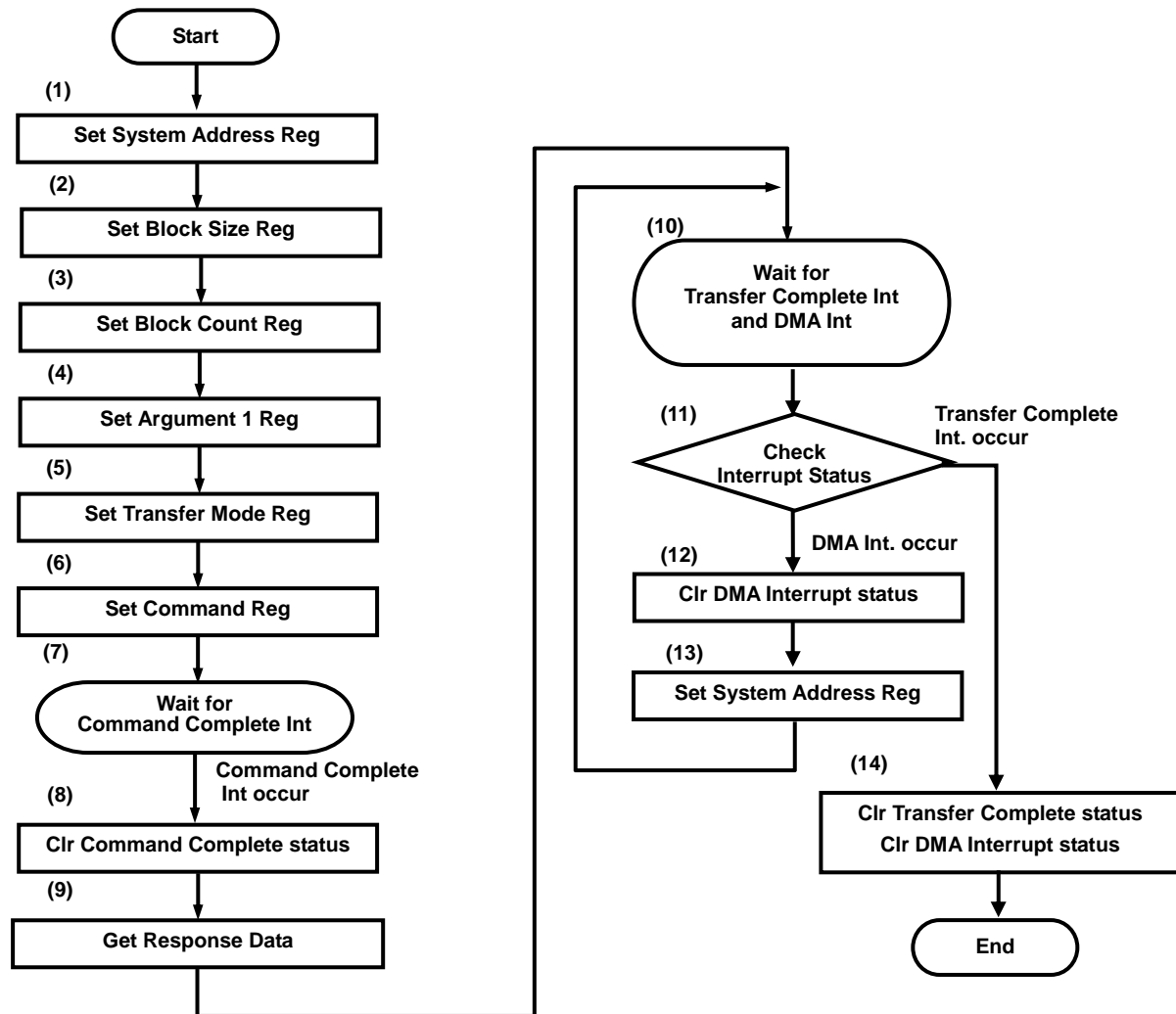

Figure 3-14: Transaction Control with Data Transfer Using DAT Line Sequence (Using SDMA)

SD Host Controller Simplified Specification Version 3.00

- (1) Data location of system memory is set to the *SDMA System Address* register.
- (2) Set the value corresponding to the executed data byte length of one block in the *Block Size* register.
- (3) Set the value corresponding to the executed data block count in the *Block Count* register in accordance with Table 2-8.
- (4) Set the argument value to the *Argument 1* register.
- (5) Set the value to the *Transfer Mode* register. The host driver determines **Multi / Single Block Select, Block Count Enable, Data Transfer Direction, Auto CMD12 Enable** and **DMA Enable**. **Multi / Single Block Select** and **Block Count Enable** are determined according to Table 2-8.
- (6) Set the value to the *Command* register.
Note: When writing to the upper byte [3] of the *Command* register, the SD command is issued and SDMA is started.
- (7) Then wait for the **Command Complete** Interrupt.
- (8) Write 1 to the **Command Complete** in the *Normal Interrupt Status* register to clear this bit.
- (9) Read *Response* register and get necessary information of the issued command.
- (10) Wait for the **Transfer Complete** Interrupt and **DMA Interrupt**.
- (11) If **Transfer Complete** is set 1, go to Step (14) else if **DMA Interrupt** is set to 1, go to Step (12). **Transfer Complete** is higher priority than **DMA Interrupt**.
- (12) Write 1 to the **DMA Interrupt** in the *Normal Interrupt Status* register to clear this bit.
- (13) Set the next system address of the next data position to the *System Address* register and go to Step (10).
- (14) Write 1 to the **Transfer Complete** and **DMA Interrupt** in the *Normal Interrupt Status* register to clear this bit.

Note: Step (2) and Step (3) can be executed simultaneously. Step (5) and Step (6) can also be executed simultaneously.

3.7.2.3 Using ADMA

The sequence for using ADMA is shown below.

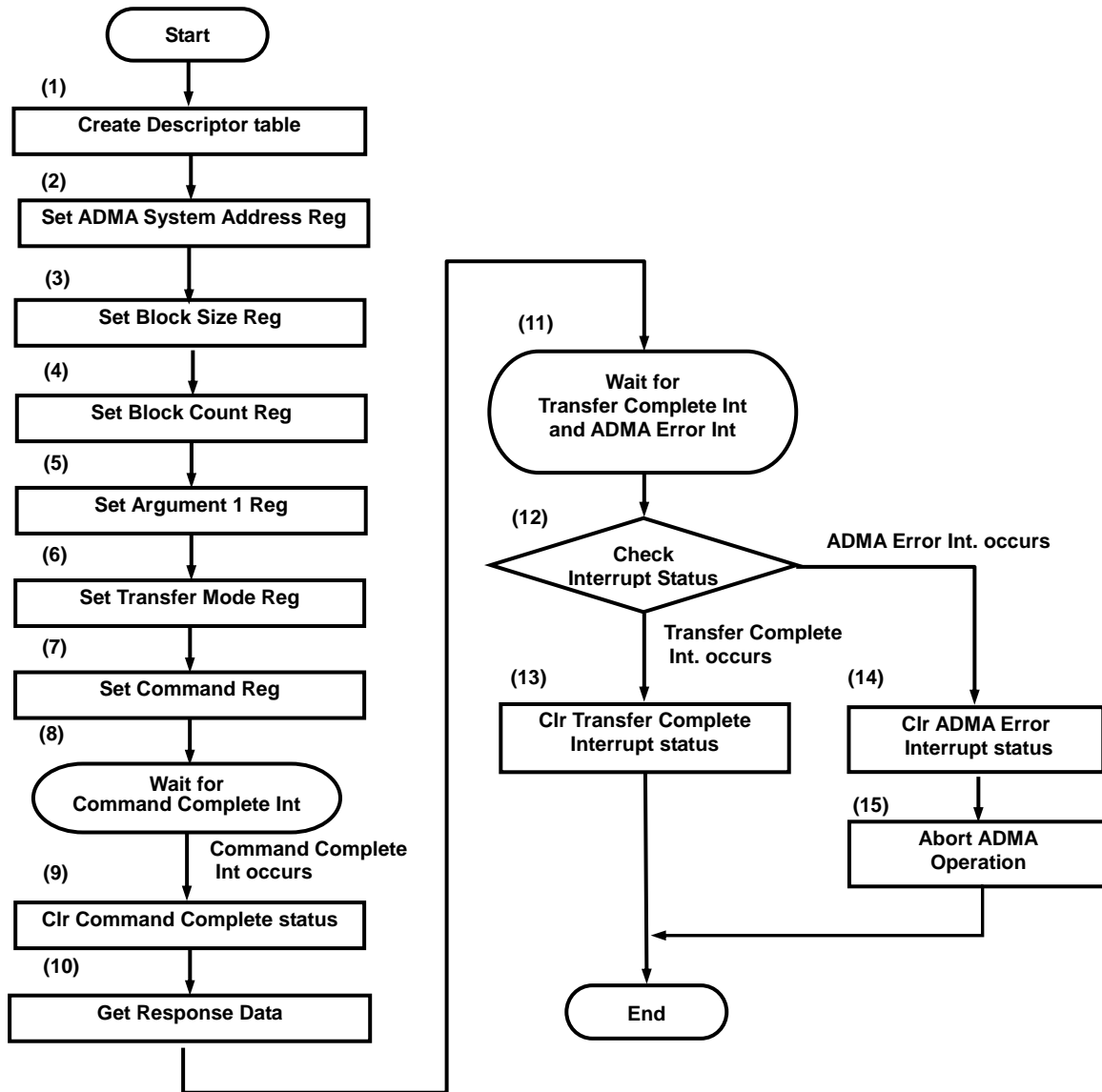

Figure 3-15: Transaction Control with Data Transfer Using DAT Line Sequence (Using ADMA)

SD Host Controller Simplified Specification Version 3.00

- (1) Create Descriptor table for ADMA in the *system memory*
- (2) Set the Descriptor address for ADMA in the *ADMA System Address* register.
- (3) Set the value corresponding to the executed data byte length of one block in the *Block Size* register.
- (4) Set the value corresponding to the executed data block count in the *Block Count* register in accordance with Table 2-8.

If the **Block Count Enable** in the *Transfer Mode* register is set to 1, total data length can be designated by the *Block Count* register and the Descriptor Table. These two parameters shall indicate same data length. However, transfer length is limited by the *Block Count* register.

If the **Block Count Enable** in the *Transfer Mode* register is set to 0, total data length is designated by not *Block Count* register but the Descriptor Table. In this case, ADMA reads more data than length programmed in descriptor from SD card. Too much read operation is aborted asynchronously and extra read data is discarded when the ADMA is completed

- (5) Set the argument value to the *Argument 1* register.
- (6) Set the value to the *Transfer Mode* register. The host driver determines **Multi / Single Block Select, Block Count Enable, Data Transfer Direction, Auto CMD12 Enable** and **DMA Enable**. **Multi / Single Block Select** and **Block Count Enable** are determined according to Table 2-8.
- (7) Set the value to the *Command* register.
 Note: When writing to the upper byte [3] of the *Command* register, the SD command is issued and DMA is started.
- (8) Then wait for the **Command Complete** Interrupt.
- (9) Write 1 to the **Command Complete** in the *Normal Interrupt Status* register to clear this bit.
- (10) Read *Response* register and get necessary information of the issued command.
- (11) Wait for the **Transfer Complete** Interrupt and **ADMA Error Interrupt**.
- (12) If **Transfer Complete** is set 1, go to Step (13) else if **ADMA Error Interrupt** is set to 1, go to Step (14).
- (13) Write 1 to the **Transfer Complete Status** in the *Normal Interrupt Status* register to clear this bit.
- (14) Write 1 to the **ADMA Error Interrupt Status** in the *Error Interrupt Status* register to clear this bit.
- (15) Abort ADMA operation. SD card operation should be stopped by issuing abort command. If necessary, the host driver checks *ADMA Error Status* register to detect why **ADMA error** is generated.

Note: Step (3) and Step (4) can be executed simultaneously. Step (6) and Step (7) can also be executed simultaneously.

3.8 Abort Transaction

An abort transaction is performed by issuing CMD12 for a SD memory card and by issuing CMD52 for a SDIO card. There are two cases where the Host Driver needs to do an Abort Transaction. The first case is when the Host Driver stops Infinite Block Transfers. The second case is when the Host Driver stops transfers while a Multiple Block Transfer is executing.

There are two ways to issue an Abort Command. The first is an asynchronous abort. The second is a synchronous abort. In an asynchronous abort sequence, the Host Driver can issue an Abort Command at anytime unless **Command Inhibit (CMD)** in the *Present State* register is set to 1. In a synchronous abort, the Host Driver shall issue an Abort Command after the data transfer stopped by using **Stop At Block Gap Request** in the *Block Gap Control* register.

3.8.1 Asynchronous Abort

The sequence for Asynchronous Abort is shown in Figure 3-16.

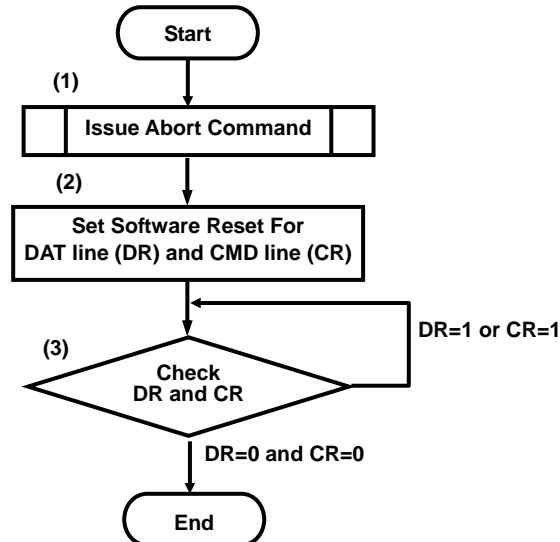

Figure 3-16: Asynchronous Abort Sequence

- (1) Issue Abort Command in accordance with Section 3.7.1
- (2) Set both **Software Reset For DAT Line** and **Software Reset For CMD Line** to 1 in the *Software Reset* register to do software reset.
- (3) Check **Software Reset For DAT Line** and **Software Reset For CMD Line** in the *Software Reset* register. If both **Software Reset For DAT Line** and **Software Reset For CMD Line** are 0, go to "End". If either **Software Reset For DAT Line** or **Software Reset For CMD Line** is 1, go to step (3).

3.8.2 Synchronous Abort

The sequence for Synchronous Abort is shown in Figure 3-17

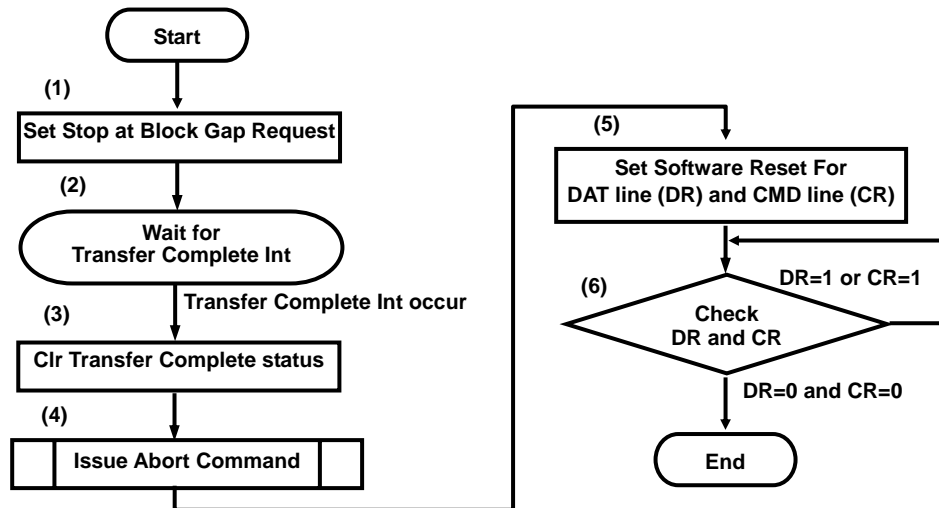

Figure 3-17: Synchronous Abort Sequence

- (1) Set the **Stop At Block Gap Request** in the *Block Gap Control* register to 1 to stop SD transactions.
- (2) Wait for the **Transfer Complete** Interrupt.
- (3) Set the **Transfer Complete** to 1 in the *Normal Interrupt Status* register to clear this bit.
- (4) Issue the Abort Command in accordance with Section 3.7.1
- (5) Set both **Software Reset For DAT Line** and **Software Reset For CMD Line** to 1 in the *Software Reset* register to do software reset.
- (6) Check both **Software Reset For DAT Line** and **Software Reset For CMD Line** in the *Software Reset* register. If both **Software Reset For DAT Line** and **Software Reset For CMD Line** are 0, go to 'End'. If either **Software Reset For DAT Line** or **Software Reset For CMD Line** is 1, go to step (6).

3.9 Changing Bus Speed Mode

This section describes the sequence for switching the bus speed mode; Default Speed, High Speed mode and UHS-I mode. The switch command (CMD6) is used to change memory card bus speed mode. The **EHS** bit (SDIO Version 2.00) or **BSS[2:0]** bits (SDIO Version 3.00) in the CCCR register is used to change the bus speed mode for SDIO card. In case of Combo card, either of the switch method changes both memory and IO bus speed mode. This means the first switch is effective. Refer to the Physical Layer Specification Version 3.0x and the SDIO Specification Version 3.00 for more information about switching bus speed. Figure 3-18 shows the sequence for switching bus speed mode for Combo Card. Note that if the card is locked, bus width cannot be changed. Unlock the card is required before changing bus width.

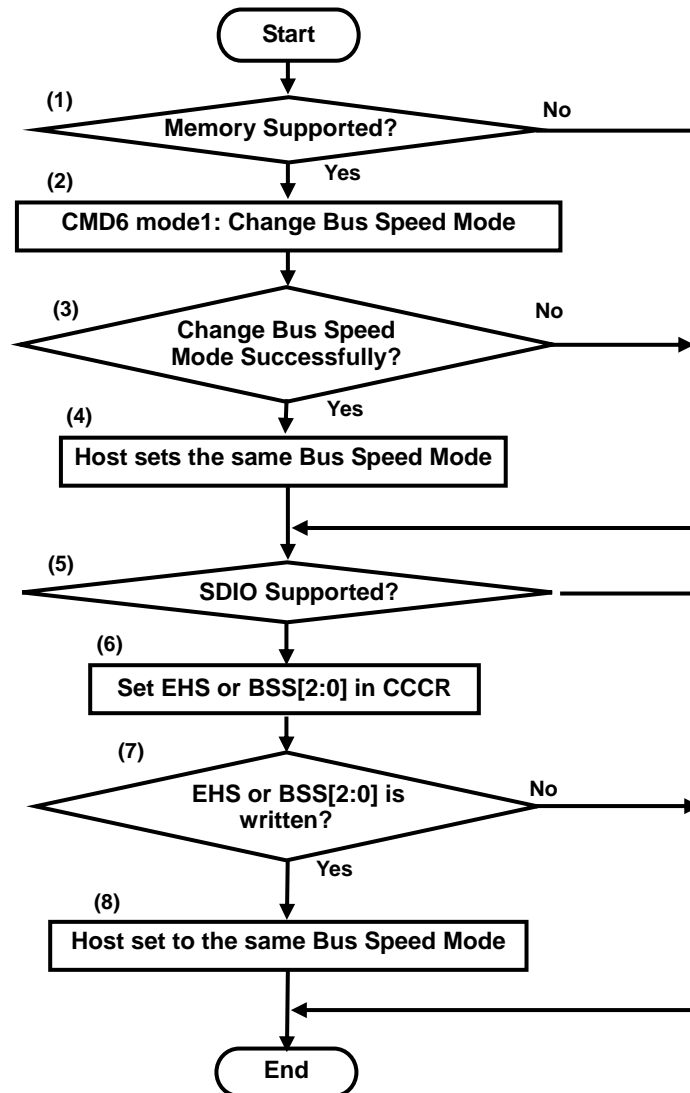

Figure 3-18 : High Speed Mode Setting for Combo Card

SD Host Controller Simplified Specification Version 3.00

- (1) The Host Driver checks if the card supports memory. If not supported, go to (5).
- (2) Issue CMD6 with mode 1 to change bus speed mode (Default, High Speed mode or UHS-I mode).
- (3) Check the response of CMD6. If the card does not supports CMD6 (no response) or bus speed is not changed successfully, go to step (5). In this case, the card is in Default Speed mode.
- (4) The Host Driver changes the Host Controller bus speed mode to the same mode.
- (5) The Host Driver checks if the card supports SDIO. If not supported, go to the end.
- (6) Issue CMD52 to write **EHS** bit or **BSS**[2:0] bits in CCCR to change bus speed mode. (The same bus speed mode of (2) shall be set.)
- (7) If **EHS** or **BSS**[2:0] are not changed successfully, go to the end.
- (8) The Host Driver changes the Host Controller bus speed to the same mode. In case of Combo card, bus speed is already changed at step (4) and this step does not affect changing bus speed.

3.10 Error Recovery

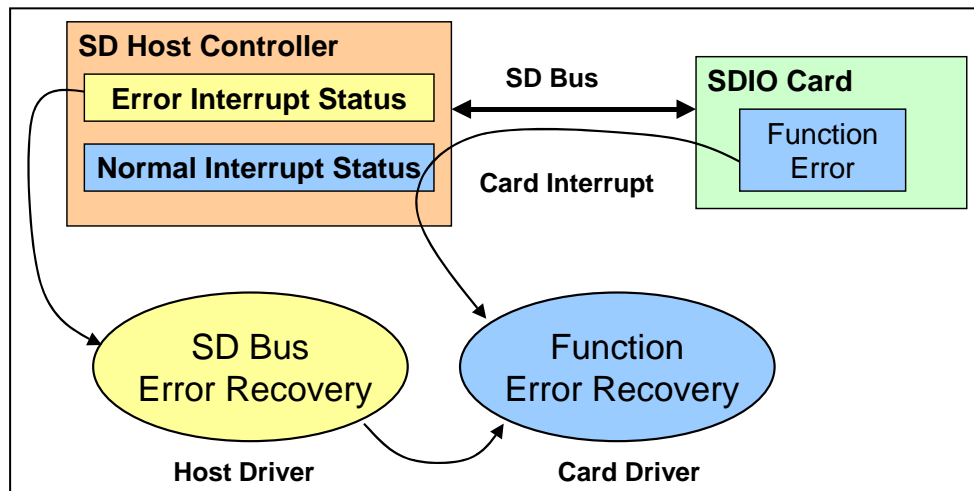

Figure 3-19 : Error Report and Recovery

Figure 3-19 shows concept of error report and its recovery. The Host Controller has 2 interrupt status registers. If an error occurs in the SD Bus transaction, one of the bits is set in the *Error Interrupt Status* register. If the function errors occur in the SDIO card, the card interrupt informs these function errors and the **Card interrupt** is set in the *Normal Interrupt Status* register. (The **Card Interrupt** is used to inform not only error statuses but also normal information. For example, to inform function ready.) The Card Driver shall do function error recovery because the Host Driver does not know how to control the function. In the case that function error occurs due to SD Bus error, SD Bus error recovery is required before function error recovery. Abort command is used to recover SD Bus, and then the Host Driver should save error statuses related to SD Bus errors before issuing abort command and transfer these statuses to the Card Driver. These statuses may be used to recover function error. Following explanations are related to SD Bus error recovery. This specification does not specify the function error recovery.

Implementation Note:

If the Card Driver cannot recover the function errors, the Host Driver should try following methods.

- (4) Using **IOEx** for SDIO card

IOEx may be used as the reset per function basis. Sequence is as follows:

Clear **IOEx**=0 and wait until **IORx**=0 and then set **IOEx**=1 again. SDIO may be recovered when **IORx**=1.

- (5) Using reset command for memory and SDIO card

Re-initialization sequence is required.

- (6) Off and on power supply for the SD Bus

The card may be recovered by the power on reset. Re-initialization sequence is required.

The two cases where the Host Driver needs the "Error Recovery" sequence are classified as follows:

- (1) Error Interrupt Recovery:

If error interrupt is indicated by the *Error Interrupt Status* register, the Host Driver shall apply this sequence.

- (2) Auto CMD12 Error Recovery:

If there are errors in Auto CMD12, the Host Driver shall apply this sequence. In terms of Return Status, Auto CMD12 Error Recovery is classified into 4 cases. It is shown in Figure 3-20. If error occurs during memory write transfer, strongly recommend using ACMD22 and then in the following recovery sequence, retry to send remaining blocks not written.

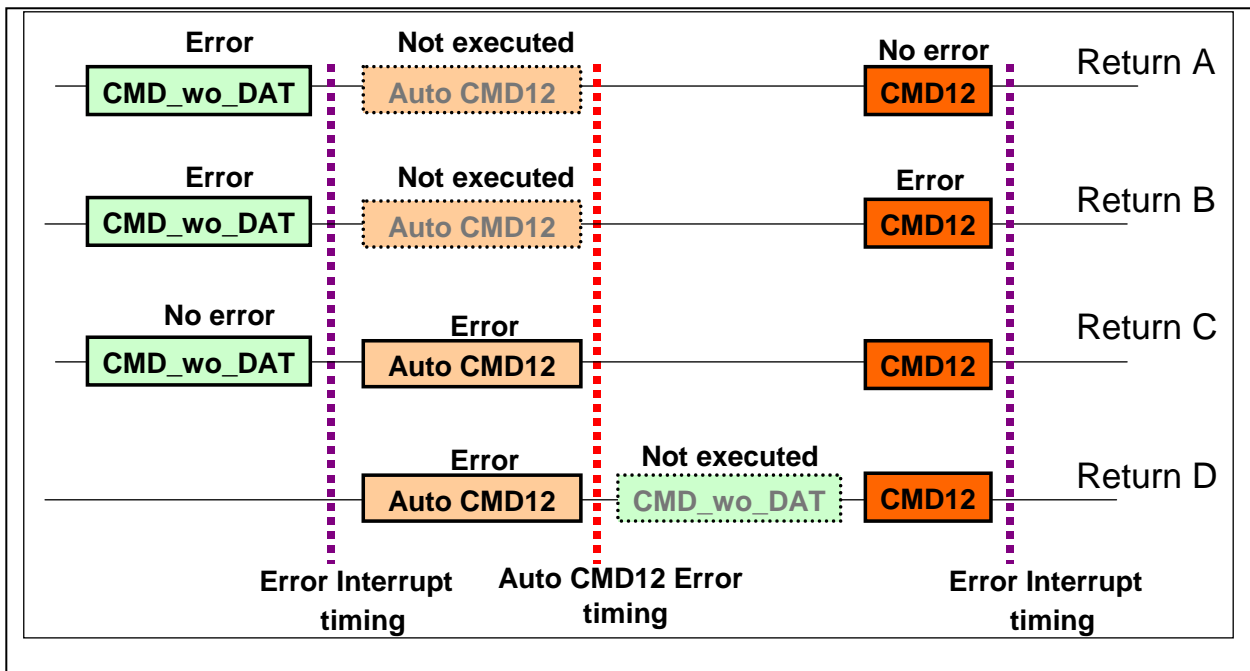

Figure 3-20: Return Status of Auto CMD12 Error Recovery

Implementation Note:

Abort command is used to recover from SD Bus error. SDIO transaction abort using CMD52 returns response but in the case of memory transaction abort using CMD12, response returns depending on the memory card state. If no response returns after issue CMD12, the Host Driver should check card state using CMD13. If the state is "tran" in the CURRENT_STATE, consider CMD12 is successful.

Implementation Note:

The following sequence is one possible error recovery flow. There may be another methods, sometimes using interrupts or polling. It can be possible to use another flows, based on Host System requirements.

In these error recovery sequences, return statuses for the next sequence. When the Host Controller cannot issue the next command due to SD Bus error, the error recovery sequences return "Non-recoverable" status. In this case, the Host System may cut off power to the SD Bus, and then power on SD Bus and initialize both the Host Controller and the SD card again.

3.10.1 Error Interrupt Recovery

The sequence for Error Interrupt Recovery is shown in Figure 3-21.

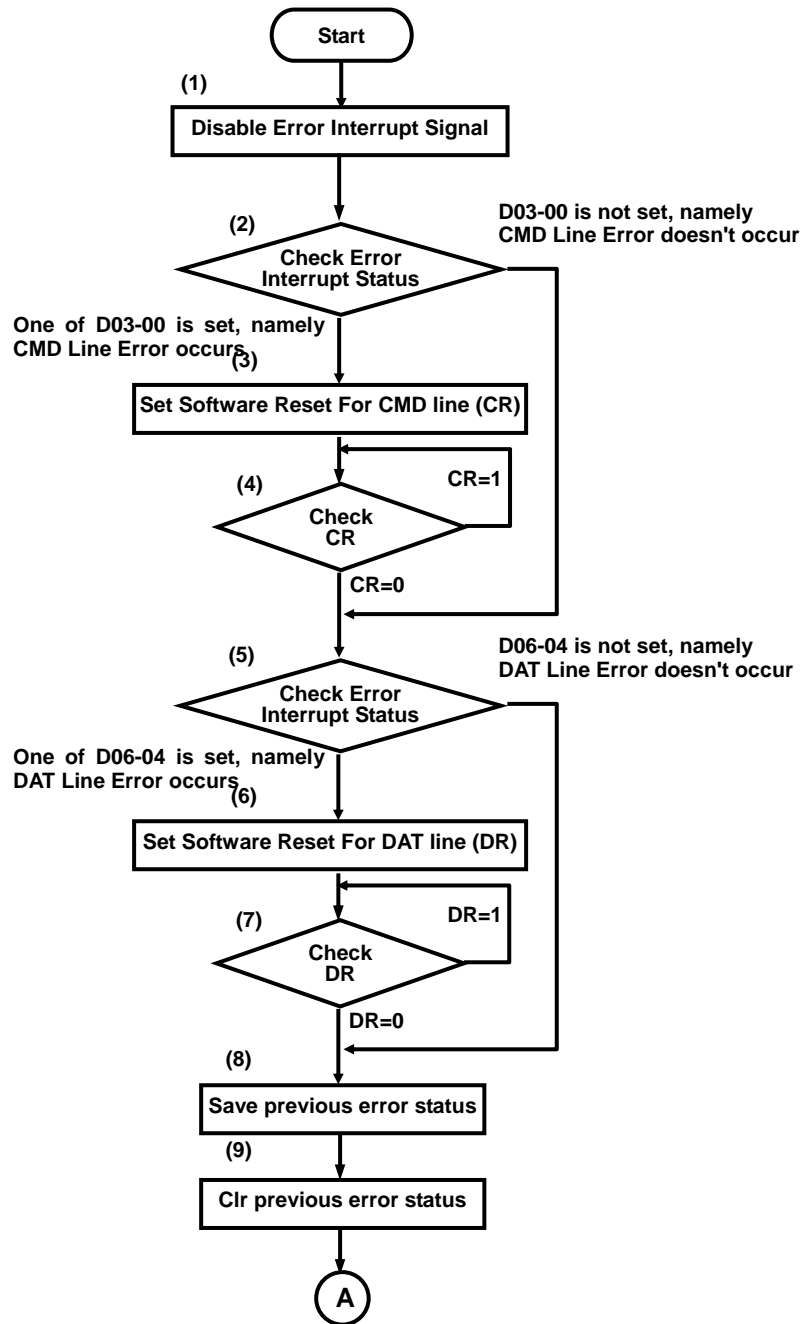

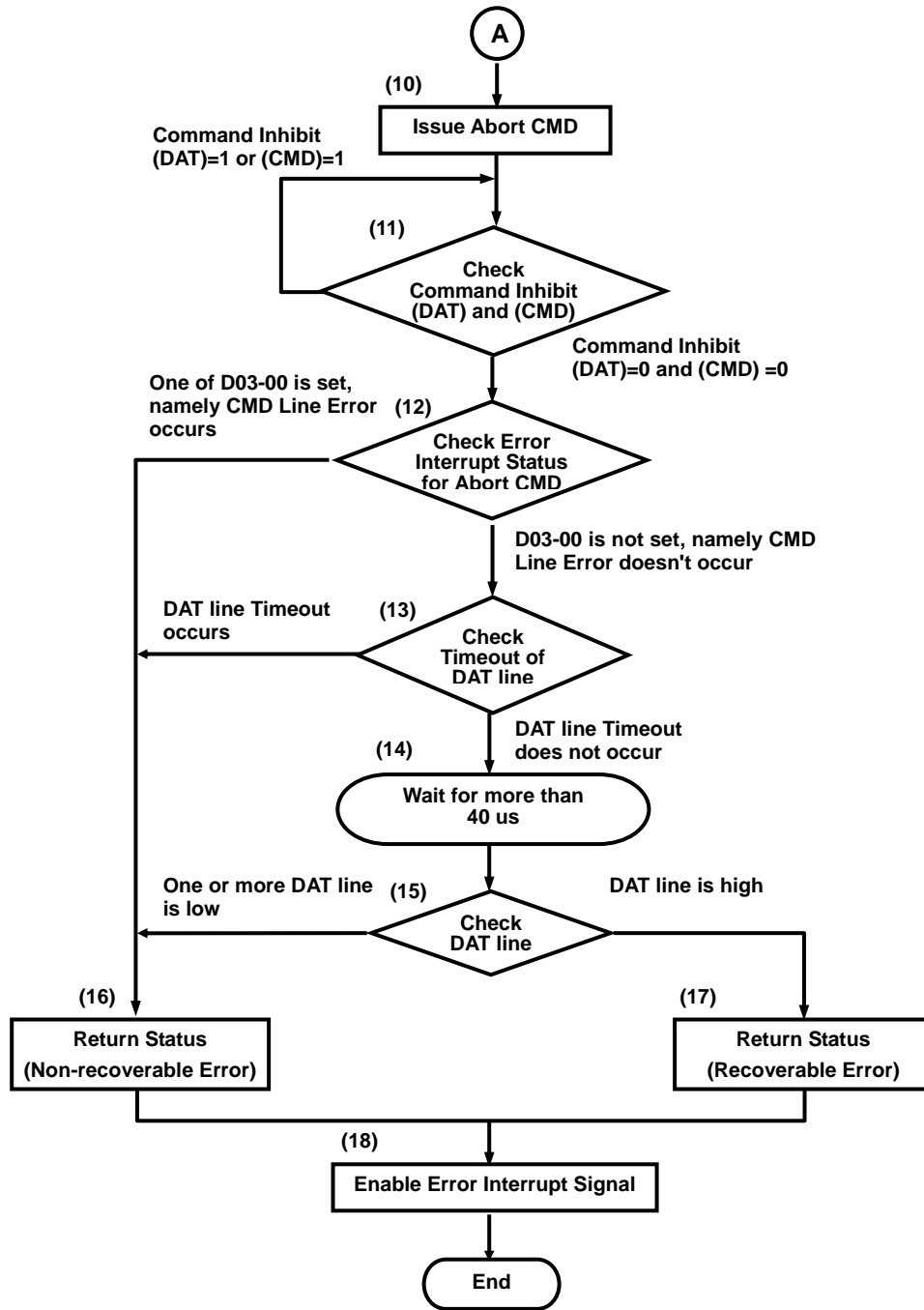

Figure 3-21: Error Interrupt Recovery Sequence

- (1) Disable the Error Interrupt Signal.
- (2) Check bits D03-00 in the *Error Interrupt Status* register. If one of these bits (D03-00) is set to 1, go to step (3). If none are set to 1 (all are 0), go to step (5).
- (3) Set **Software Reset For CMD Line** to 1 in the *Software Reset* register for software reset of the CMD line.
- (4) Check **Software Reset For CMD Line** in the *Software Reset* register. If **Software Reset For CMD Line** is 0, go to step (5). If it is 1, go to step (4).
- (5) Check bits D06-04 in the *Error Interrupt Status* register. If one of these bits (D06-04) is set to 1, go to step (6). If none are set to 1 (all are 0), go to step (8).
- (6) Set **Software Reset For DAT Line** to 1 in the *Software Reset* register for software reset of the DAT line.
- (7) Check **Software Reset For DAT Line** in the *Software Reset* register. If **Software Reset For DAT Line** is 0, go to step (8). If it is 1, go to step (7).
- (8) Save previous error status.
- (9) Clear previous error status with setting them to 1.
- (10) Issue Abort Command.
- (11) Check **Command Inhibit (DAT)** and **Command Inhibit (CMD)** in the *Present State* register. Repeat this step until both **Command Inhibit (DAT)** and **Command Inhibit (CMD)** are set to 0.
- (12) Check bits D03-00 in the *Error Interrupt Status* register for Abort Command. If one of these bits is set to 1, go to step (16). If none of these bits are set to 1 (all are 0), go to step (13).
- (13) Check **Data Timeout Error** in the *Error Interrupt Status* register. If this bit is set to 1, go to step (16). If it is 0, go to step (14).
- (14) Wait for more than 40 us.
- (15) By monitoring the **DAT [3:0] Line Signal Level** in the *Present State* register, judge whether the level of the DAT line is low or not. If one or more DAT lines are low, go to step (16). If the DAT lines are high, go to step (17).
- (16) Return Status of "Non-recoverable Error".
- (17) Return Status of "Recoverable Error".
- (18) Enable the Error Interrupt Signal.

3.10.2 Auto CMD12 Error Recovery

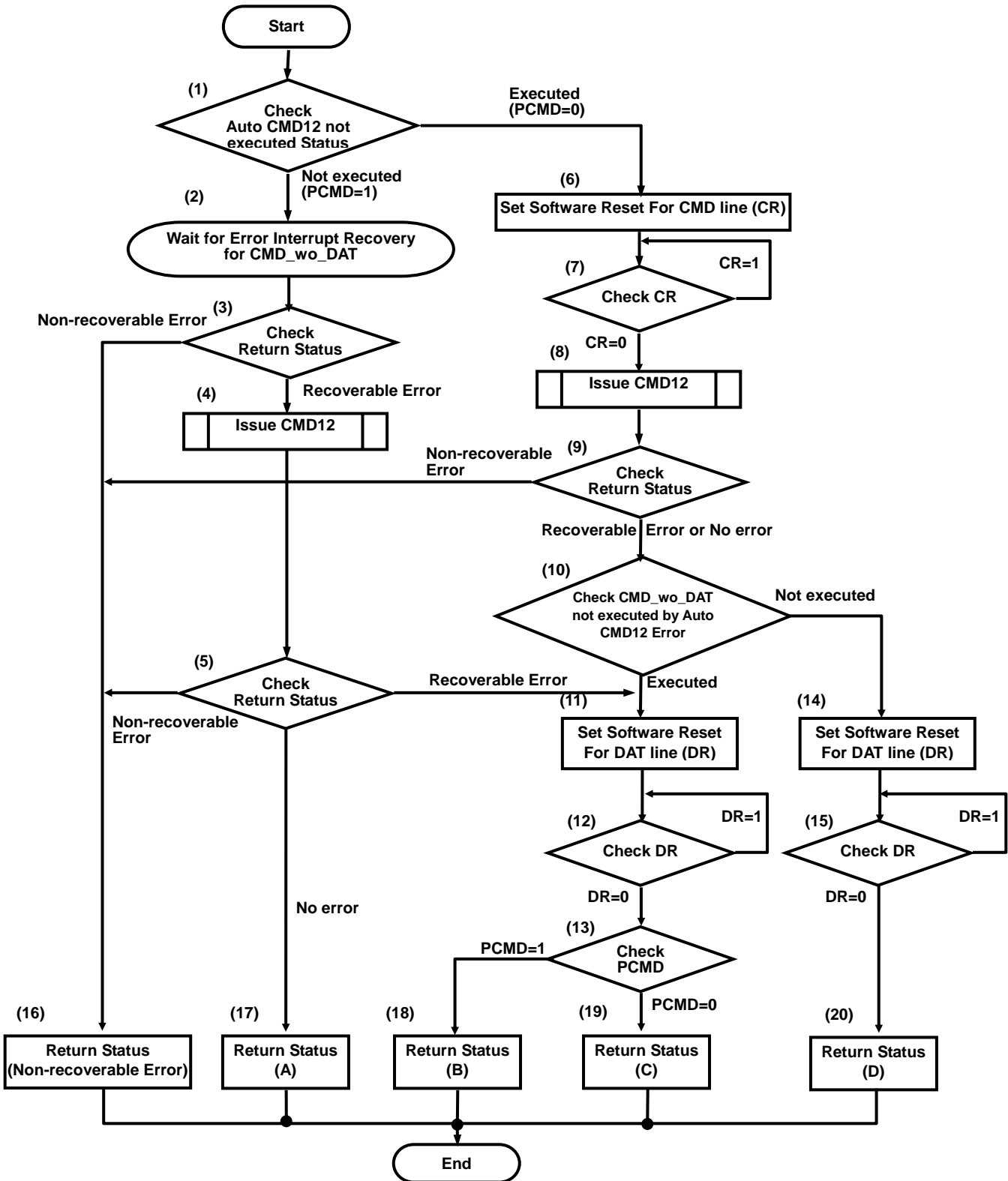

Figure 3-22 : Auto CMD12 Error Recovery Sequence

The sequence for Auto CMD12 Error Recovery is shown in Figure 3-22. Following four cases A-D shall be covered.

- A: An error occurred in CMD_wo_DAT, but not in the SD memory transfer.
- B: An error occurred in CMD_wo_DAT, and also occurred in the SD memory transfer.
- C: An error did not occur in CMD_wo_DAT, but an error occurred in the SD memory transfer.
- D: CMD_wo_DAT was not issued, and an error occurred in the SD memory transfer.

- (1) Check **Auto CMD12 Not Executed** in the *Auto CMD Error Status* register. If this bit is set to 1, go to step (2). If this bit is set to 0, go to step (6). In addition, the Host Driver shall define **PCMD** flag, which changes to 1 if **Auto CMD12 Not Executed** is set to 1.
- (2) Wait for Error Interrupt Recovery for CMD_wo_DAT.
- (3) Check "Return Status". In the case of "Non-recoverable Error", go to step (16). In the case of "Recoverable Error", go to step (4).
- (4) Issue CMD12 in accordance with Section 3.7.1
- (5) If the **CMD** line errors occur for the CMD12 (One of D03-00 is set in the *Error Interrupt Status* register), "Return Status" is "Non-recoverable Error" and go to step (16). If not **CMD** line error and busy timeout error occur (D04 is set in the *Error Interrupt Status* register), "Return Status" is "Recoverable Error" and go to step (11). Otherwise, "Return Status" is "No error" and go to step (17).
- (6) Set **Software Reset For CMD Line** to 1 in the *Software Reset* register for software reset of the CMD line.
- (7) Check **Software Reset For CMD Line** in the *Software Reset* register. If **Software Reset For CMD Line** is 0, go to step (8). If it is 1, go to step (7).
- (8) Issue CMD12 according to Section 3.7.1. Acceptance of CMD12 depends on the state of the card. CMD12 may make the card to return to tran state. If the card is already in tran state, the card does not response to CMD12.
- (9) Check "Return Status" for CMD12. If "Return Status" returns "Non-recoverable Error", go to step (16). In the case of "Recoverable Error" or "No error", go to step (10).
- (10) Check the **Command Not Issued By Auto CMD12 Error** in the *Auto CMD Error Status* register. If this bit is 0, go to step (11). If it is 1, go to step (14).
- (11) Set **Software Reset For DAT Line** to 1 in the *Software Reset* register for software reset of the DAT line.
- (12) Check **Software Reset For DAT Line** in the *Software Reset* register. If **Software Reset For DAT Line** is 0, go to step (13). If it is 1, go to step (12).
- (13) Check the **PCMD** flag. If **PCMD** is 1, go to step (18). If it is 0, go to step (19).
- (14) Set **Software Reset For DAT Line** to 1 in the *Software Reset* register for software reset of the DAT line.
- (15) Check **Software Reset For DAT Line** in the *Software Reset* register. If **Software Reset For DAT Line** is 0, go to step (20). If it is 1, go to step (15).
- (16) Return Status of "Non-recoverable Error".
- (17) Return Status that an error has occurred in CMD_wo_DAT, but not in the SD memory transfer.
- (18) Return Status that an error has occurred in both CMD_wo_DAT, and the SD memory transfer.
- (19) Return Status that an error has not occurred in CMD_wo_DAT, but has occurred in the SD memory transfer.
- (20) Return Status that CMD_wo_DAT has not been issued, and an error has occurred in the SD memory transfer.

3.11 Wakeup Control (Optional)

After the Host System goes into standby mode, the Host System can resume from standby via a wakeup event initiated by one of the following three events:

- (1) Interrupt from a SD card:
If an SD card interrupt occurs, the Host System can resume from standby mode. If the Host System uses this wakeup factor, SD Bus power shall be kept on.
- (2) Insertion of SD card:
If a SD card is inserted, the Host System can resume from standby mode.
- (3) Removal of SD card:
If a SD card is removed, the Host System can resume from standby mode.

The sequence for preparing wakeup before the Host System goes into standby mode is shown in Figure 3-23.

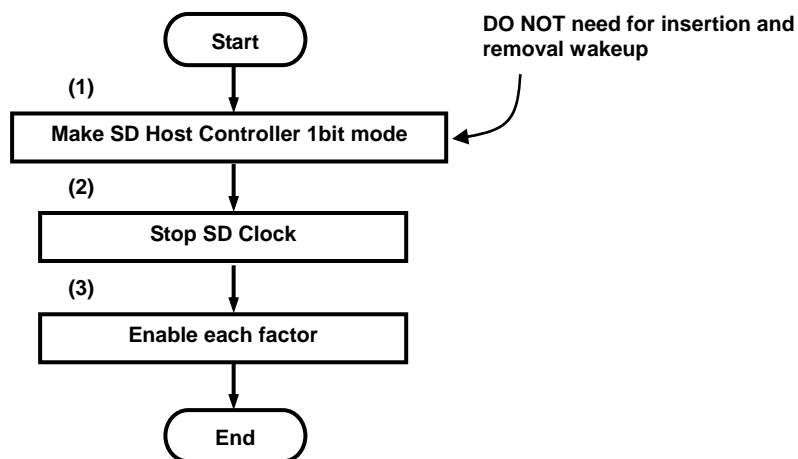

Figure 3-23: Wakeup Control before Standby Mode

- (1) Set **Data Transfer Width** to 0 in the *Host Control 1* register.
- (2) Set **SD Clock Enable** to 0 in the *Clock Control* register.
- (3) Clear the *Normal Interrupt Status* register and the *Normal Interrupt Signal Enable* register, and then set the enable bits of each wakeup event factor to 1 in the *Wakeup Control* register and set the bits of *Normal Interrupt Status Enable* register to use wakeup.

The sequence for wakeup once in standby mode is shown in Figure 3-24.

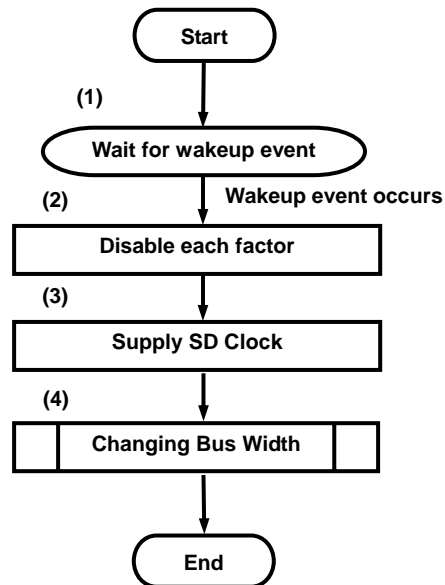

Figure 3-24: Wakeup from Standby

- (1) Wait for wakeup event.
- (2) Set the enable bits of each wakeup event factor to 0 in the *Wakeup Control* register and then clear event statuses in the *Normal Interrupt Status* register. If necessary, set the *Normal Interrupt Signal Enable* register.
- (3) Set **SD Clock Enable** to 1 in the *Clock Control* register.
- (4) Set the SD Bus width in accordance with Section 3.4.

3.12 Suspend/Resume (Optional)

If a SD card supports suspend and resume functionality, then the Host Controller can initiate suspend and resume. It is necessary for both the Host Controller and the SD card to support the function of "Read Wait". ADMA operation does not support this function.

3.12.1 Suspend Sequence

The sequence for suspend is shown in Figure 3-25.

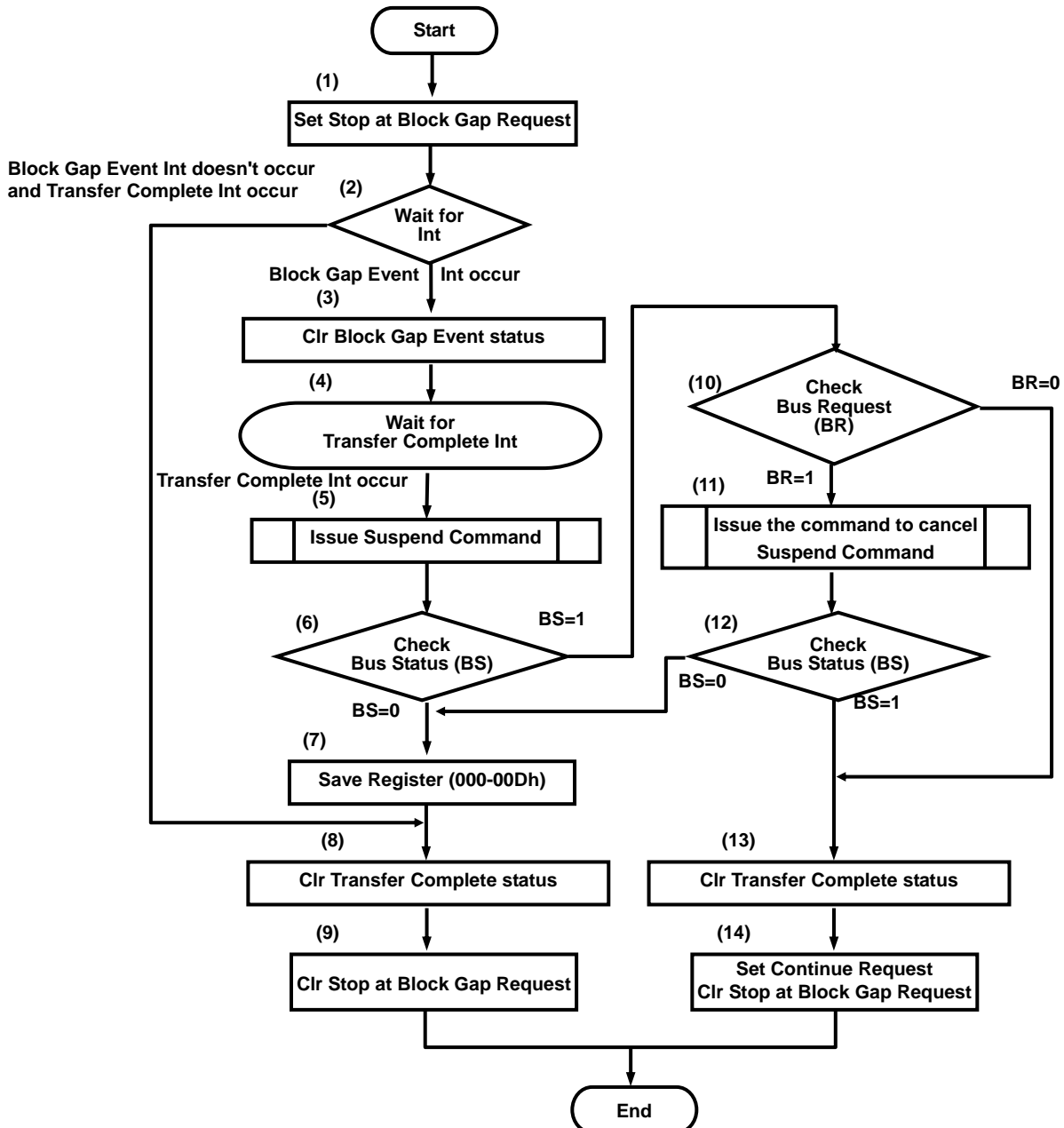

Figure 3-25 : The Sequence for Suspend

- (1) Set **Stop At Block Gap Request** to 1 in the *Block Gap Control* register to stop the SD transaction.
- (2) Wait for an Interrupt. If **Block Gap Event** is set to 0 and **Transfer Complete** is set to 1 in the *Normal Interrupt Status* register, go to step (8). If **Block Gap Event** is set to 1, go to step (3).
- (3) Set **Block Gap Event** to 1 in the *Normal Interrupt Status* register to clear this bit.
- (4) Wait for the **Transfer Complete** Interrupt.
- (5) Issue the Suspend Command in accordance with Section 3.7.1.
- (6) Check the **BS** value of the response data. If **BS** is 0, go to step (7). If **BS** is 1, go to step (10).
- (7) Save the register (000h-00Dh).
- (8) Set Transfer Complete to 1 in the *Normal Interrupt Status* register to clear this bit.
- (9) Set **Stop At Block Gap Request** to 0 in the Block Gap Control register to clear this bit.
- (10) Check the **BR** value of the response data. If **BR** is 1, go to step (11). If **BR** is 0, go to step (13).
- (11) Issues the command to cancel the previous suspend command in accordance with Section 3.7.1 Transaction Control without **Data Transfer Using DAT Line**.
- (12) Check the **BS** value of the response data. If **BS** is 0, go to step (7). If **BS** is 1, go to step (13).
- (13) Set **Transfer Complete** to 1 in the *Normal Interrupt Status* register to clear this bit.
- (14) Set **Continue Request** to 1 in the Block Gap Control register to continue the transaction. At the same time, write 0 to **Stop At Block Gap Request** to clear this bit.

The Table 3-1 shows conditions to be able to use Suspend / Resume function.

Conditions			Suspend/Resume Function	
Host Suspend/Resume Support	Card Suspend/Resume Support	Card Read Wait Support	Write Suspend/Resume	Read Suspend/Resume
Not supported	Don't care	Don't care	Cannot be used	Cannot be used
Supported	Not supported	Don't care	Cannot be used	Cannot be used
Supported	Supported	Not supported	Can be used	Cannot be used
Supported	Supported	Supported	Can be used	Can be used

Table 3-1 Suspend / Resume Condition

3.12.2 Resume Sequence

The sequence for resume is shown in Figure 3-26.

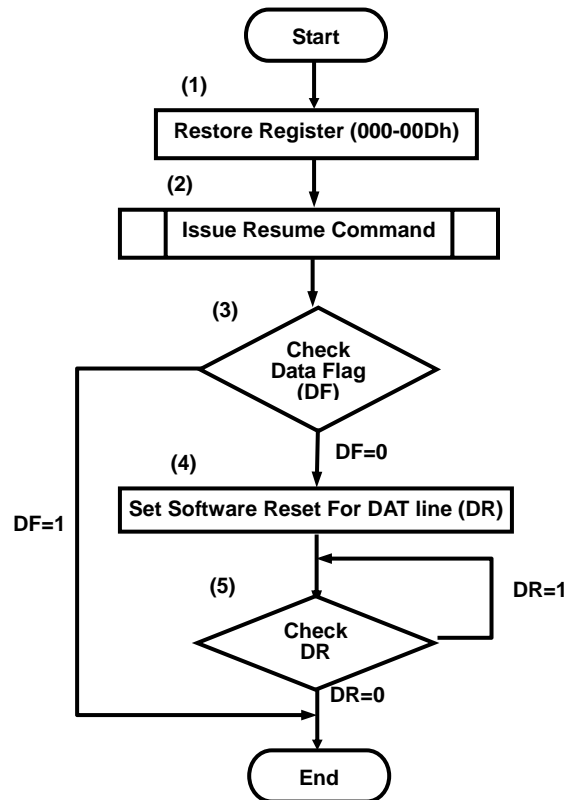

Figure 3-26 : The Sequence for Resume

- (1) Restore the register (000h-00Dh).
- (2) Issue the Resume Command in accordance with Section 3.7.1.
- (3) Check the **DF** value of the response data. If **DF** is 0, go to step (4). If **DF** is 1, go to 'End'.
- (4) Set **Software Reset For DAT Line** to 1 in the *Software Reset* register for software reset of the DAT line.
- (5) Check **Software Reset For DAT Line** in the *Software Reset* register. If **Software Reset For DAT Line** is 0, go to 'End'. If it is 1, go to step (5).

3.12.3 Read Transaction Wait / Continue Timing

Implementation Note:

Read Wait, **DAT Line Active** and **Read Transfer Active** shall be set and cleared by the Host Controller.

Stop At Block Gap Request shall be set and cleared by the Host Driver.

Continue Request shall be set by the Host Driver and be cleared by the Host Controller.

Block Gap Event and **Transfer Complete** shall be set by the Host Controller and be cleared by the Host Driver.

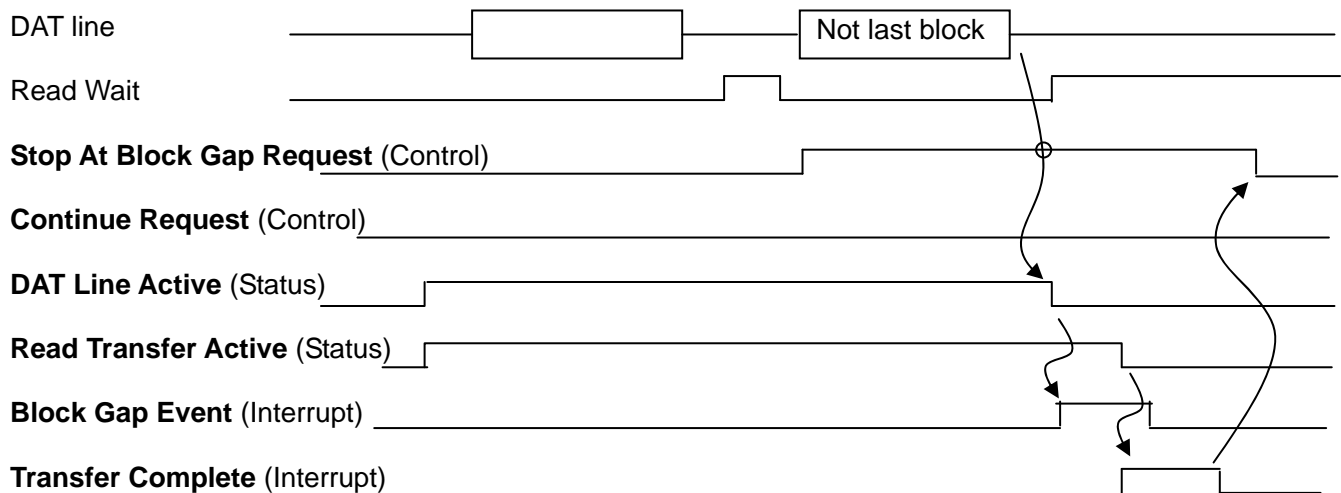

Figure 3-27 : Wait Read Transfer by Stop At Block Gap Request

The Host Controller can accept a **Stop At Block Gap Request** when all the following conditions are met.

- (1) It is at the block gap.
- (2) The Host Controller can assert read wait or it is already asserted.
- (3) **Read Wait Control** is set to 1.

After accepting the Stop At Block Gap Request

- (1) Clear **DAT Line Active** status and generate the **Block Gap Event** Interrupt
- (2) After all valid data has been read (No valid read data remains in the Host Controller), clear the **Read Transfer Active** status and generate the **Transfer Complete** Interrupt.
- (3) After accepting **Transfer Complete** Interrupt, clear the **Stop At Block Gap Request**

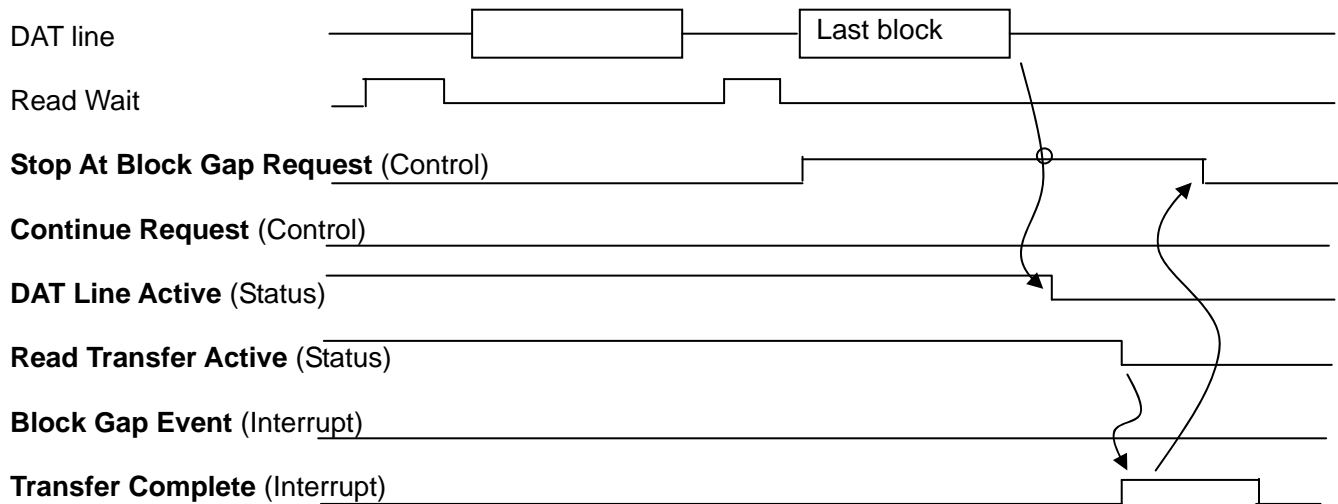

Figure 3-28 : Stop At Block Gap Request is Not Accepted at the Last Block of the Read Transfer

If the **Stop At Block Gap Request** is set to 1 during the last block transfer, the Host Controller shall not accept the **Stop At Block Gap Request** and stops the transaction normally. The **Block Gap Event** Interrupt is not generated. When the **Transfer Complete** Interrupt is generated, and if the **Block Gap Event** status is not set to 1, the driver shall clear the **Stop At Block Gap Request**.

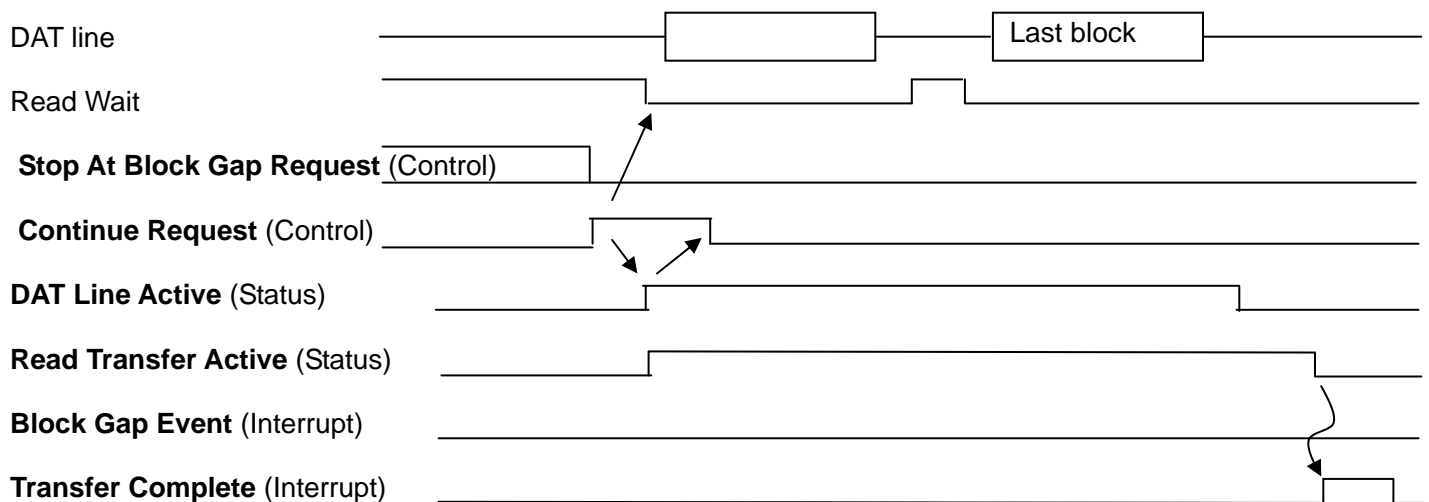

Figure 3-29 : Continue Read Transfer by Continue Request

To restart a stopped data transfer, set the **Continue Request** to 1. (The **Stop At Block Gap Request** shall be set to 0.)

After accepting the **Continue Request**,

- (1) Release Read Wait (if the data block can accept the next data.)
- (2) Set the **DAT Line Active** status and the **Read Transfer Active** status
- (3) The **Continue Request** is automatically cleared by (2).

The end of the read transfer is specified by data length.

- (1) Clear the **DAT Line Active** status and do not generate the **Block Gap Event** Interrupt.
- (2) After all valid data has been read (No valid read data remains in the Host Controller), clear the **Read Transfer Active** status and generate the **Transfer Complete** Interrupt.

3.12.4 Write Transaction Wait / Continue Timing

Implementation Note:

DAT Line Active and **Write Transfer Active** shall be set and cleared by the Host Controller.

Stop At Block Gap Request shall be set and cleared by the Host Driver.

Continue Request shall be set by the Host Driver and be cleared by the Host Controller.

Block Gap Event and **Transfer Complete** shall be set by the Host Controller and be cleared by the Host Driver.

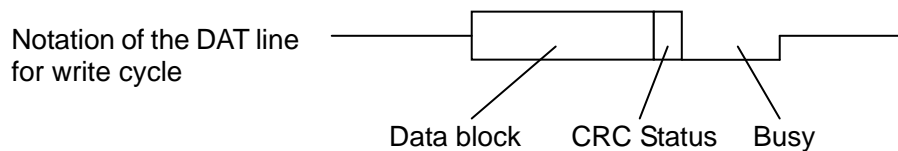
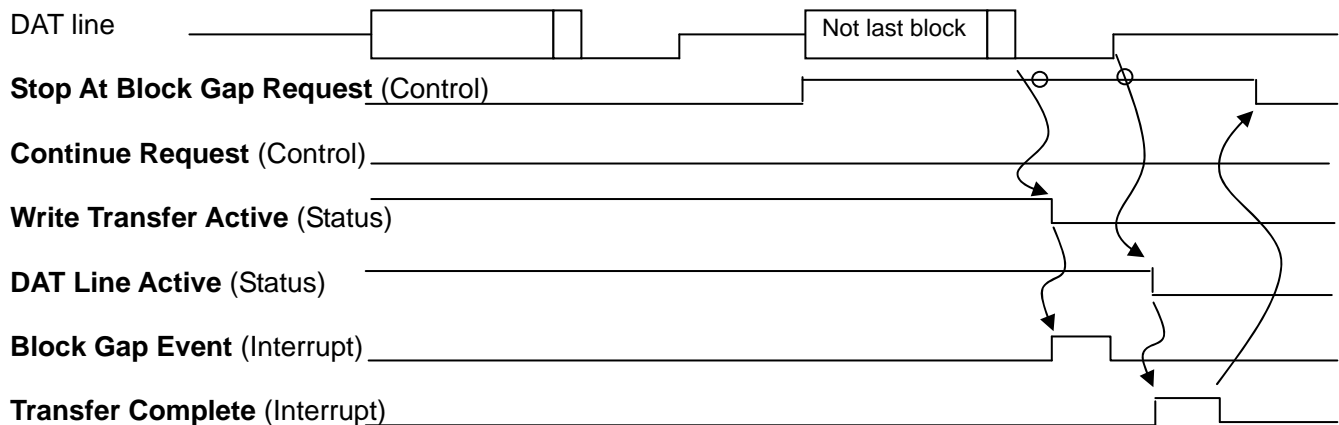

Figure 3-30 : Wait Write Transfer by Stop At Block Gap Request

The Host Controller can accept the **Stop At Block Gap Request** when matches all following conditions

- (1) It is at the block gap.
- (2) No valid write data remains in the Host Controller

After accepting the **Stop At Block Gap Request**

- (1) Clear the **Write Transfer Active** Status and generate the **Block Gap Event** Interrupt
- (2) After the busy signal is released, clear the **DAT Line Active** status and generate the **Transfer Complete** Interrupt.
- (3) After accepting the **Transfer Complete** Interrupt, clear the **Stop At Block Gap Request**

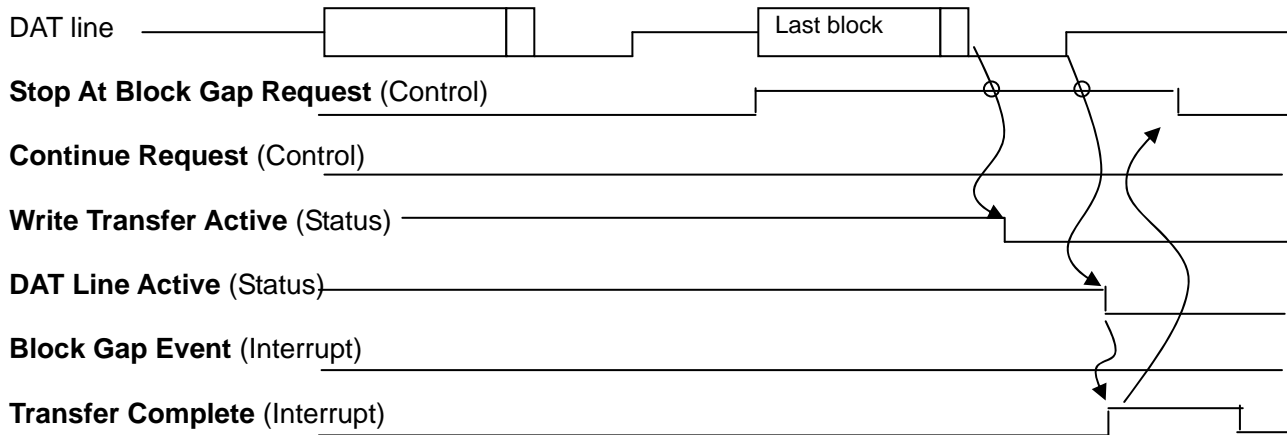

Figure 3-31 : Stop At Block Gap Request is Not Accepted at the Last Block of the Write Transfer

If the **Stop At Block Gap Request** is set to 1 during the last block transfer, the Host Controller shall not accept the **Stop At Block Gap Request** and terminates the transaction normally. The **Block Gap Event** Interrupt is not generated. When the **Transfer Complete** Interrupt is generated, and if the **Block Gap Event** Interrupt Status is not set to 1, the driver shall clear the **Stop At Block Gap Request**.

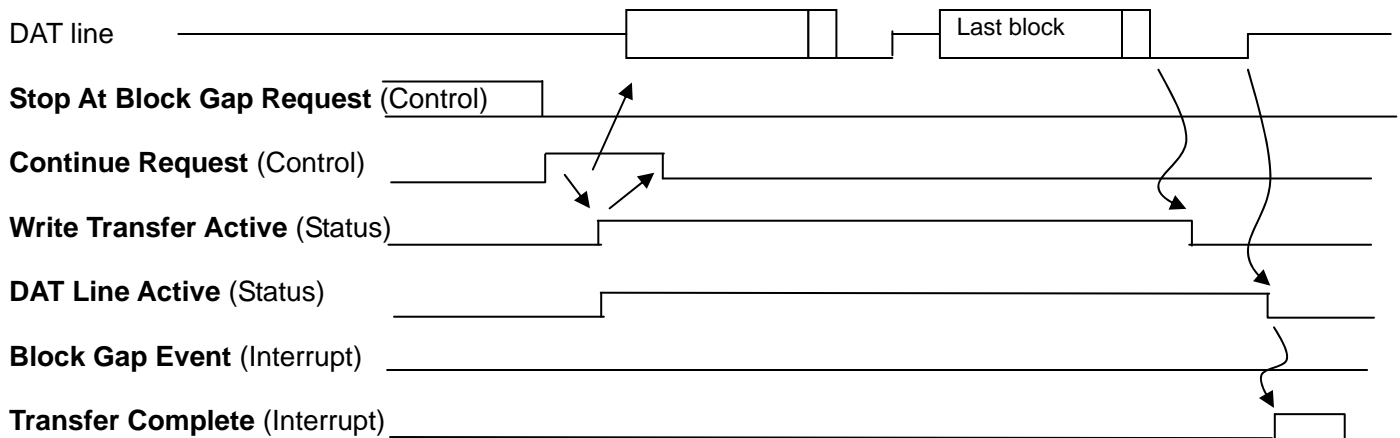

Figure 3-32 : Continue Write Transfer by Continue Request

To restart a stopped data transfer, set the **Continue Request** to 1. (**Stop At Block Gap Request** shall be set to 0.)

After accepting the **Continue Request**:

- (1) Set the **DAT Line Active** status and the **Write Transfer Active** Status
- (2) The **Continue Request** is automatically cleared by (1).

The end of transfer is specified by data length.

- (1) Clear the **Write Transfer Active** Status, and do not generate the **Block Gap Event** Interrupt
- (2) After the busy signal is released, clear the **DAT Line Active** status and generates the **Transfer Complete** Interrupt.

Appendix A (Normative) : Reference

A.1 Reference

This specification refers extensively to any released version of the following SD specifications and the related Supplementary Notes.

SD Specifications Part 1 Physical Layer Specification Version 3.00

SD Specifications Part 1 Physical 3.00 Supplementary Notes Version 1.00 Draft

SD Specifications Part 1 Physical Layer Specification Version 3.01 Draft

SD Specifications Part 1 eSD Addendum Version 2.10

SD Specifications Part 2 File System Specification Version 3.00

SD Specifications Part 3 File Security Specification Version 3.00

SD Specifications Part E1 SDIO Card Specification Version 3.00 Draft

PCI Bus Power Management Interface Specification Revision 1.1 December 1998

PCI Local Bus Specification Revision 2.3 March 2002

Appendix B (Normative) : Special Terms

B.1 Abbreviations and Terms

ACPI	Advanced Configuration and Power Interface: PCI bus supports ACPI.
ADMA	Advanced DMA: This term stands for ADMA1 and ADMA2.
ADMA1	ADMA Version 1: 4KByte boundary base ADMA
ADMA2	ADMA Version 2: Without 4KByte boundary limitation.(Recommended to support)
API	Application Program Interface
Auto CMD12	Host Controller function to issue CMD12 to stop multiple-block operation.
Auto CMD23	Host Controller function to issue CMD23 to stop multiple-block operation.
Block Gap	Period between blocks of data
Block	a number of bytes, basic data transfer unit
Busy	Busy signal: SD card drives busy on DAT[0] line.
CCCR	Card Common Control Register: One of registers defined in SDIO card.
CCS	Card Capacity Status: A field name in the response of ACMD41.
CDCLK	Card Detect Clock: a clock for detecting SD card
CID	Card Identification number register
Clr	Clear
CMD	SD bus command line
CMDXX	SD commands: XX indicates one or two digit decimal command number.
CMD_wo_DAT	Commands without using DAT line
CRC	Cyclic Redundancy Check
CSD	Card Specific Data register
DAT	SD bus 4-bit Data line: It is also expressed by DAT[3:0]
Descriptor Table	Sequence of ADMA Programs created on system memory.
DMA	Direct Memory Access: This term stands for SDMA, ADMA1 and ADMA2.
GPS	Global Positioning System
HCS	Host Capacity Support: A field name in the argument of ACMD41.
HW	Hardware
Int	Interrupt: SD card drives interrupt on DAT[1] line.
LED	Light Emitting Diode
OCR	Operation Conditions Register
OS	Operating System
Page Size	Unit of system memory management. Most host system adopts 4KB page size.
PCI	Peripheral Component Interconnect
PHS	Personal Handyphone System
PME	Power Management Enable
Resume	Restore and restart a suspended function. It is defined in SDIO spec.
RCA	Relative Card Address Register: RCA is received from CMD3.
SDCD#	Card Detect Signal: a signal, which is active in a level of low, for detecting SD card.
SDCLK	SD bus clock line: Host supplies clock to card through this line.
SDMA	Single Operation DMA defined in the Host Controller Specification Ver1.00.
SDR50	One of UHS-I modes up to 50MB/sec bus speed.
SDR104	One of UHS-I modes up to 104MB/sec bus speed.
SDWP	a signal, which is active in a level of high, for detecting SD card to be protected writing
Suspend	Stop and save a function to be able to resume. It is defined in SDIO spec.
TMCLK	a clock for detecting a timeout on DAT line
UHS-I	Ultra High Speed Version 1

Appendix C : PCI Configuration Register

As regards PCI bus interface, the Host Driver requires some information in the PCI Configuration registers to identify the SD Host Controller. It is specified in Appendix A of this specification.

C.1 Register Maps

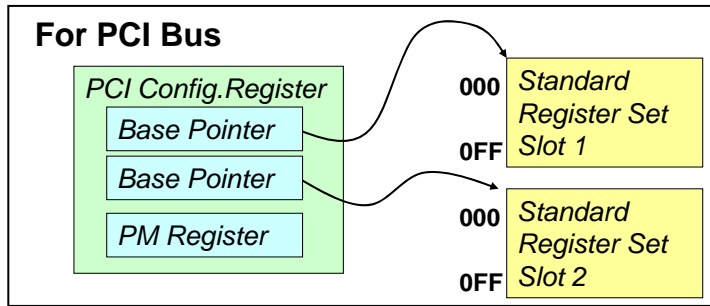

Figure C- 1 : Register Set for PCI Device (Example for 2 slots)

The PCI Configuration register is a special register to support Plug & Play and ACPI power management. The PCI Configuration registers for the PCI Based SD Host Controller is defined as appendix A.

Multiple slots can be supported through the use of multiple Base Addresses within a single PCI Function. Each of these Base Addresses is configured through the *Base Address* registers at offsets 10h to 24h in the PCI Configuration Space Header. The PCI Specification allows for a PCI Function to have up to six Base Addresses. As such, a PCI Based SD Host Controller can support up to a total of six SD Slots.

A PCI Based SD Host Controller shall configure the *Base Address* register of each supported SD Slot such that it is a memory base address with at least 256 bytes allocated. This allows for enough memory address space in each Base Address to access all of the registers defined in this specification. Each set of the SD registers shall be implemented in a separate Base Address.

The values of Power Management register specified in the PCI Configuration registers should refer to the current and consumption values for all slots combined. It shall be read the total amount of power used by the PCI Based SD Host Controller, whether it has a single slot or multiple slots.

If Host Controller requires vendor specific register area, additional 256bytes area is added after the standard register area as shown Figure C- 2.

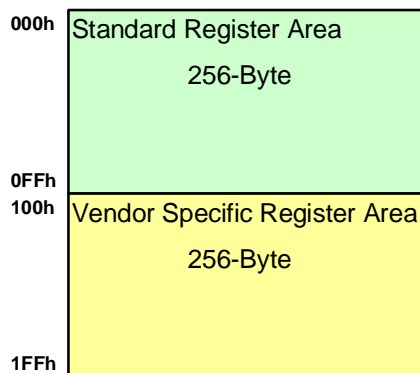

Figure C- 2 : Vendor Specific Register Area Extension

C.2 SD Controller Configuration Register MAP

31	23	15	07	00	Port
Device ID		Vendor ID			00h
Status		Command			04h
Class Code			Revision ID		08h
Header Type					0Ch
Base Address(es)					10-27h
Subsystem Device ID		Subsystem Vendor ID			2Ch
		Capability Pointer			30h
		Interrupt Pin			34h
		Interrupt Line			38h
		Slot Information			3Ch
					40h
Power Management Capabilities (PMC)		Next Item Ptr		Capability ID	44-7Fh
Data	PMCSR PCI to PCI Bridge Support (PMCSR_BSE)	Power Management Control/Status (PMCSR)			80h
					84h
					88-FFh

Table C- 1 : PCI Configuration Register for Standard SD Host Controller

PCI configuration space is divided into 3 areas.

00h - 3Fh : Registers defined in the PCI Bus Interface Specification

40h - 7Fh : Register area reserved for the SD Host Specification

Slot Information assigns to 40h and 41h-7Fh is reserved for future.

80h - FFh : Register area reserved for vendor unique registers

Implementation Note:

The Host Controller should place Power Management registers anywhere in the vendor unique register area. The offset address of Power Management register is set by *Capability Pointer* register. The Table C- 1 shows the case of offset being 80h (registers from 80h to 87h).

C.3 PCI Configuration Register

This section defines PCI Configuration registers that are specific for the PCI Based SD Host Controller. Refer to PCI Specification Version 2.3 for other standard PCI Configuration registers.

C.3.1 Class Code Register (Offset 09h)

D31	D24	D23	D16	D15	D08
Basic Class		Sub Class		Interface Code	

Figure C- 3 : PCI Config. Class Code Register

Location	Attrib	
31-24 (0Bh)	RO	Basic Class
		08h: General Peripheral
23-16 (0Ah)	RO	Sub Class
		05h: for SD Host Controller
15-08 (09h)	RO	Interface Code
		00h: Standard Host not supported DMA
		01h: Standard Host supported DMA
		02h: Vendor unique SD Host Controller

Table C- 2 : PCI Config. Class Code Register

C.3.2 Base Address Register (Offset 10h)

Maximum 6 base addresses can be supported, In case of multiple functions controller; these registers are used to point location not only for the SD Host Controller register sets but also for other functions. Refer to C.3.3 Slot Information Register to identify which base address is used for the SD Host Controller.

D31	D08	D07	D01	D00
Base Address			00 0000	Space Indicator

Figure C- 4 : PCI Config. Base Address Register for 256Byte Register Map

Location	Attrib	
31-08	RW	Base Address The SD Host Controller register set is mapped on a memory space of 256bytes starting from this base address.
07-01	RO	Fixed to 00 0000b.
00	RO	Space Indicator Set to 0 if mapped to the memory space.

Table C- 3 : PCI Config. Base Address Register for 256Byte Register Map

D31	D09	D08	D01	D00
Base Address			000 0000	Space Indicator

Figure C- 5 : PCI Config. Base Address Register for 512Byte Register Map

Location	Attrib	
31-09	RW	Base Address The SD Host Controller register set is mapped on a memory space of 512bytes starting from this base address. Refer to Figure C- 2.
08-01	RO	Fixed to 000 0000b.
00	RO	Space Indicator Set to 0 if mapped to the memory space.

Table C- 4 : PCI Config. Base Address Register for 512Byte Register Map

Implementation Note:

Multiple slot support Host Controller use Base Address registers at offsets 10h to 24h in the PCI Configuration register. Format of all Base Address registers are the same as this register. Not used Base Address registers shall be zero with RO type.

Offset 10h:	Slot1
Offset 14h:	Slot2
Offset 18h:	Slot3
Offset 1Ch:	Slot4
Offset 20h:	Slot5
Offset 24h:	Slot6

C.3.3 Slot Information Register (Offset 40h)

D07	D06	D04	D03	D02	D00
Reserved	Number of slots		Reserved	First Base Address Register Number	

Figure C- 6 : PCI Config. Slot Information Register

Location	Attrib																			
07	Rsvd	Reserved																		
06-04	RO	<p>Number Of Slots These statuses indicate the number of slots the Host Controller supports. In the case of single function, maximum 6 slots can be assigned.</p> <table border="1"> <tbody> <tr> <td>000b:</td> <td>1 slot</td> </tr> <tr> <td>001b:</td> <td>2 slot</td> </tr> <tr> <td>010b:</td> <td>3 slot</td> </tr> <tr> <td>011b:</td> <td>4 slot</td> </tr> <tr> <td>100b:</td> <td>5 slot</td> </tr> <tr> <td>101b:</td> <td>6 slot</td> </tr> </tbody> </table>	000b:	1 slot	001b:	2 slot	010b:	3 slot	011b:	4 slot	100b:	5 slot	101b:	6 slot						
000b:	1 slot																			
001b:	2 slot																			
010b:	3 slot																			
011b:	4 slot																			
100b:	5 slot																			
101b:	6 slot																			
03	Rsvd	Reserved																		
02-00	RO	<p>First Base Address Register Number Up to 6 Base Address can be specified in single configuration. These bits indicate first Base Address register number assigned for SD Host Controller register set. In the case of single function and multiple register sets, contiguous base addresses are used. Number Of Slot specifies number of base address.</p> <table border="1"> <tbody> <tr> <td>000b:</td> <td>Base Address 10h</td> <td>(BAR0)</td> </tr> <tr> <td>001b:</td> <td>Base Address 14h</td> <td>(BAR1)</td> </tr> <tr> <td>010b:</td> <td>Base Address 18h</td> <td>(BAR2)</td> </tr> <tr> <td>011b:</td> <td>Base Address 1Ch</td> <td>(BAR3)</td> </tr> <tr> <td>100b:</td> <td>Base Address 20h</td> <td>(BAR4)</td> </tr> <tr> <td>101b:</td> <td>Base Address 24h</td> <td>(BAR5)</td> </tr> </tbody> </table>	000b:	Base Address 10h	(BAR0)	001b:	Base Address 14h	(BAR1)	010b:	Base Address 18h	(BAR2)	011b:	Base Address 1Ch	(BAR3)	100b:	Base Address 20h	(BAR4)	101b:	Base Address 24h	(BAR5)
000b:	Base Address 10h	(BAR0)																		
001b:	Base Address 14h	(BAR1)																		
010b:	Base Address 18h	(BAR2)																		
011b:	Base Address 1Ch	(BAR3)																		
100b:	Base Address 20h	(BAR4)																		
101b:	Base Address 24h	(BAR5)																		

Table C- 5 : PCI Config. Slot Information Register

C.4 The Relation between Device State, Power and Clock

Table C- 6 shows Power Management policies when a SD card is inserted.

State	Card Power	SD Clock	Bus Mode	SD Bus Action
D0	On	On	4 or 1 bit ¹⁾	Any SD transaction or Interrupt
D1	On	On	4 or 1 bit ¹⁾	Long busy indication or Interrupt
D2	On	Off	4 or 1 bit ²⁾	Long busy indication or Interrupt
D3 hot	On or Off ³⁾	Off	4 or 1 bit ²⁾	Interrupt only
D3 cold	On or Off ³⁾	Off	4 or 1 bit ²⁾	Interrupt only

Table C- 6 : The Relation between Device State, Power and Clock

- 1) Setting to 4 bit mode is recommended.
- 2) If **Asynchronous Interrupt Enable** is set to 1, 4-bit mode can be used.
- 3) If PME is supported in the D3 state, card power shall be supplied.

The relations between card power supply and Device states are shown below:

In the D0 state, while a SD card is inserted or not rejected, card power shall be supplied by setting the **SD Bus Power** in the *Power Control* register. In the D1 or D2 states, the Host Driver shall keep the preceding power supply state. In the D3 state, if the Host System supports card interrupt wakeup, the card power shall keep on. In all states, when the SD card is removed after the card power is supplied, the Host Controller shall shut off the card power and clear the **SD Bus Power** in *Power Control* register automatically.

The relations between the SD Clock and Device states are shown below:

In the D0 state, while the SD card is inserted or not rejected, the SD Clock shall be supplied by setting the **SD Clock Enable** in the *Clock Control* register. In the D1 state, the Host Driver shall keep the state of the SD Clock while in the D0 state. In the D2 and D3 states, the Host Controller shall stop the SD Clock regardless of the **SD Clock Enable**. If a card supports wakeup and **Asynchronous Interrupt Enable** in the *Host Control 2* register is set to 0, the SD Bus mode shall be changed to 1-bit mode just before transferring from the D0 state. In all states, when the SD card is removed after the card power has been supplied, the Host Controller shall stop the SD Clock and clear the **SD Clock Enable** automatically.

In case a slot is for embedded device, following rule is applied.

In D2 and D3 state, when a device supports wakeup and **Interrupt Pin Select** in the *Shared Bus Control* register is set to 0 and **Asynchronous Interrupt Enable** in the *Host Control 2* register is set to 0, a driver needs to change to 1-bit mode. Otherwise, it is possible to keep 4-bit mode.

In D3 state, VDDH should be supplied regardless of supporting PME.

In D3 cold state, back-end power should be stopped by a driver.

C.5 Generate PME Interrupt by the Wakeup Events

PME interrupt is generated by rising edge of three interrupt statuses that gated by *Wakeup Event Enable* (Refer to Section 1.8). Writing 1 to the **PME Status** clears its status.

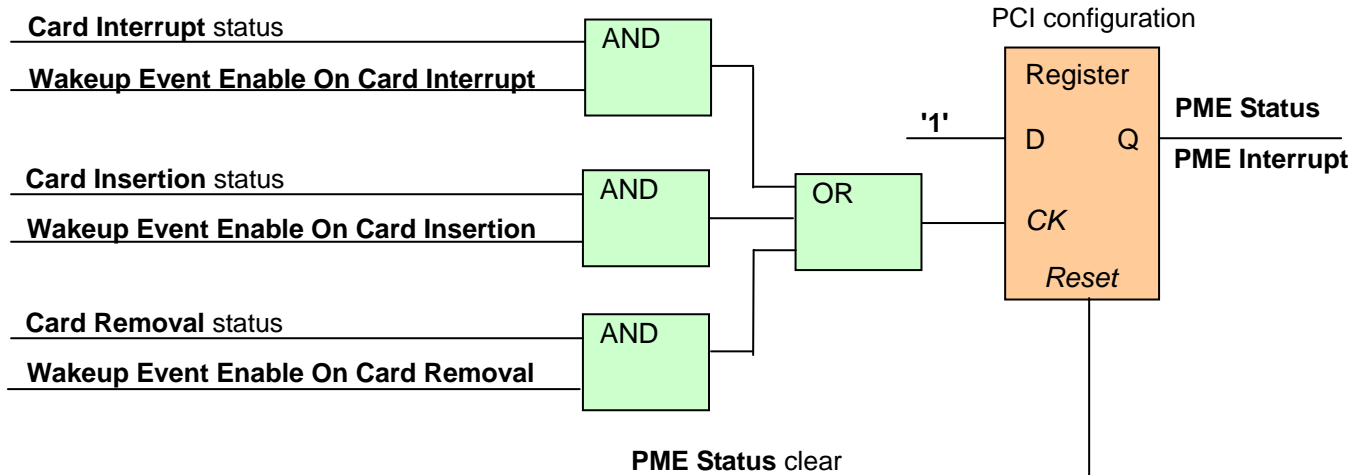

Figure C- 7 : Condition to Generate PME Interrupt

Appendix D : Shared Bus Supported Host Controller

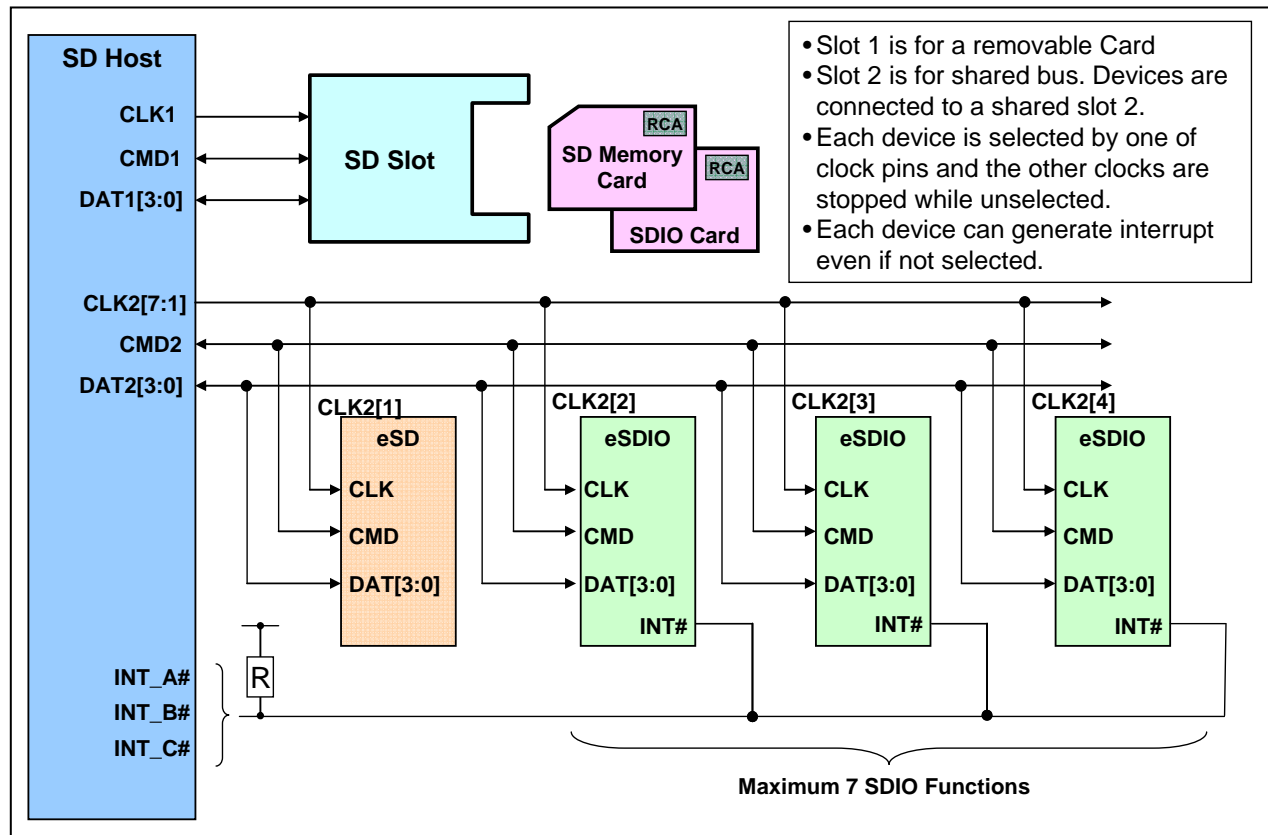

Figure D- 1 : Example Configuration Supporting Card Slot and Shared Bus

Figure D- 1 shows an example configuration of a system supporting a card slot and shared bus. A card slot bus and shared bus are separated so that removal card is not influence on the devices on shared bus. SD Bus signals except clock signal are connected together on the shared bus. Each device is selected by individual clock pins. An example timing of clock signals is shown in Figure 2-38. Stopping clock for unselected device enables system to reduce power consumption of devices. Even if SD bus clock is stopped, a SDIO device can generate interrupt by INT# pin to request a service to Host System. INT is asynchronous interrupt, low active, open drain and then can be wired-or with interrupt pin of another device. Pull-up resistor is required for INT# signal.